

## General Purpose Silicon Rectifier

### Features

- The plastic package carries Underwriters Laboratory Flammability Classification 94V-0
- Construction utilizes void-free molded plastic technique
- Low reverse leakage
- High forward surge current capability
- Lead free in comply with EU RoHS 2011/65/EU directives

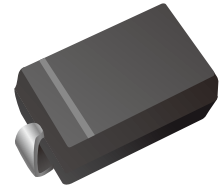

### Mechanical Data

- Case:SMA
- Terminals: leads solderable per MIL-STD-750, Method 2026
- Polarity: Color band denotes cathode end
- Mounting Position: Any

### Ordering Information

Part Number	Marking	Shipping	Reel
SM528-TR5	M528	5000PCS Tape&Reel	13 inches
SM528-TR7K5	M528	7500PCS Tape&Reel	13 inches

### Maximum Ratings And Electrical Characteristics

Ratings at 25°C ambient temperature unless otherwise specified.  
 Single phase half-wave 60Hz, resistive or inductive load, for capacitive load current derate by 20%.

Rating	Symbol	SM528	Unit
Maximum repetitive peak reverse voltage	$V_{RRM}$	3000	V
Maximum RMS voltage	$V_{RMS}$	2100	V
Maximum DC blocking voltage	$V_{DC}$	3000	V
Maximum average forward rectified current 0.375" (9.5mm) lead length at $T_A=75^\circ\text{C}$ Peak forward surge current	$I_{(AV)}$	1.0	A
8.3ms single half sine-wave superimposed on rated load (JEDEC Method)	$I_{FSM}$	25.0	A
Maximum instantaneous forward voltage at 1 A	$V_F$	2.0	V
Maximum DC reverse current $T_A=25^\circ\text{C}$ at rated DC blocking voltage $T_A=100^\circ\text{C}$	$I_R$	5.0 150.0	$\mu\text{A}$
Typical junction capacitance (Note1)	$C_J$	15.0	pF
Typical thermal resistance (Note2)	$R_{\theta JA}$	95	$^\circ\text{C/W}$
Operating junction and storage temperature range	$T_J, T_{STG}$	-50 to +150	$^\circ\text{C}$

Note:(1) Measured at 1MHz and applied reverse voltage of 4.0V D.C.

(2) Thermal resistance from junction to ambient at 0.2 "(5mm)lead length,P.C.B. mounted.



Characteristics Curves

FIG. 1 FORWARD CURRENT DERATING CURVE

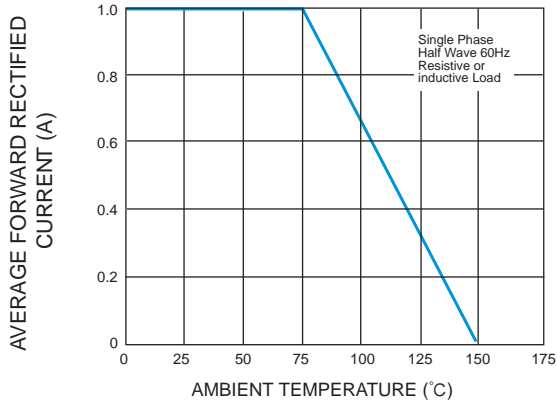

FIG. 2 MAXIMUM NON-REPETITIVE PEAK FORWARD SURGE CURRENT

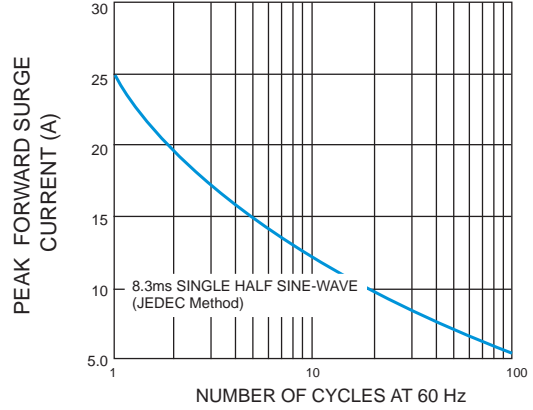

FIG. 3 TYPICAL INSTANTANEOUS FORWARD CHARACTERISTICS

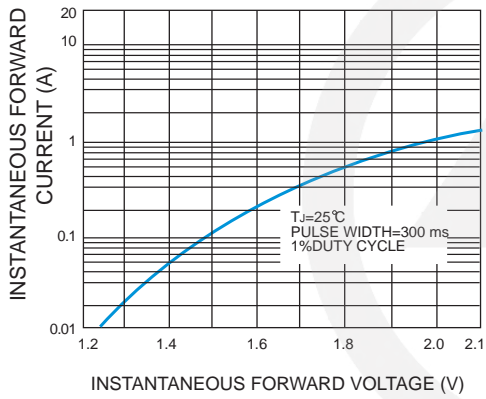

FIG. 4 TYPICAL REVERSE CHARACTERISTICS

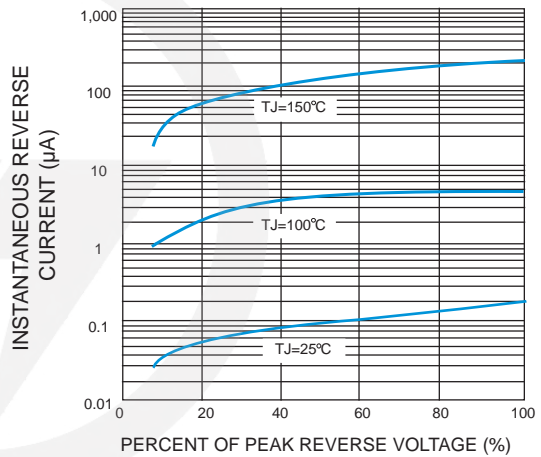

FIG. 5 TYPICAL JUNCTION CAPACITANCE

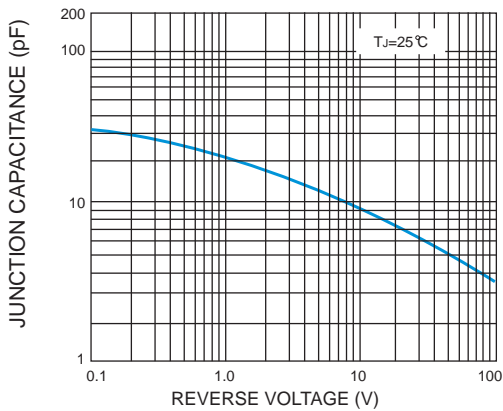
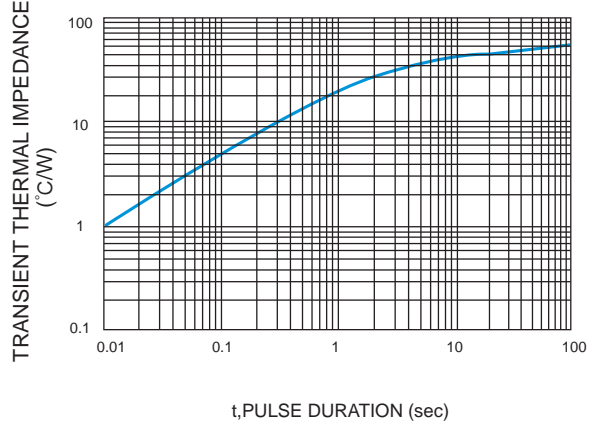
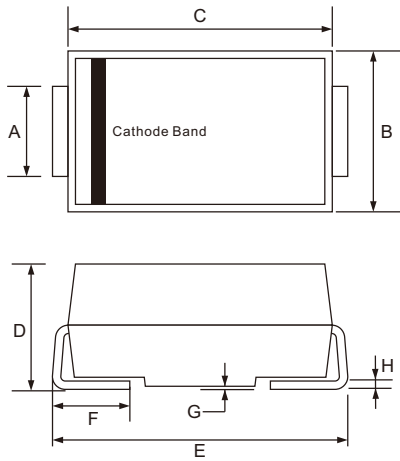

FIG. 6 TYPICAL TRANSIENT THERMAL IMPEDANCE



**SMA Package Outline**



Unit : mm

SYMBOL	DIMENSIONS	
	MIN.	MAX.
A	1.25	1.65
B	2.30	2.79
C	3.90	4.75
D	1.90	2.50
E	4.70	5.28
F	0.76	1.52
G	0.203 TYP.	
H	0.15	0.31

**SMA Suggested Pad Layout**

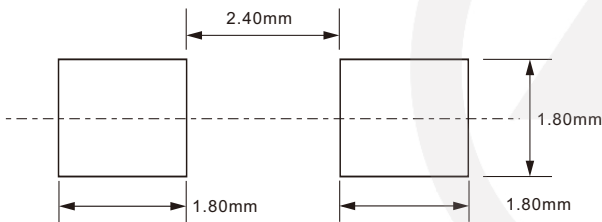

**Note:**

1. Controlling dimension: in millimeters.
2. General tolerance:  $\pm 0.05\text{mm}$
3. The pad layout is for reference purpose only.

**Carrier Tape Dimensions**

Unit : mm

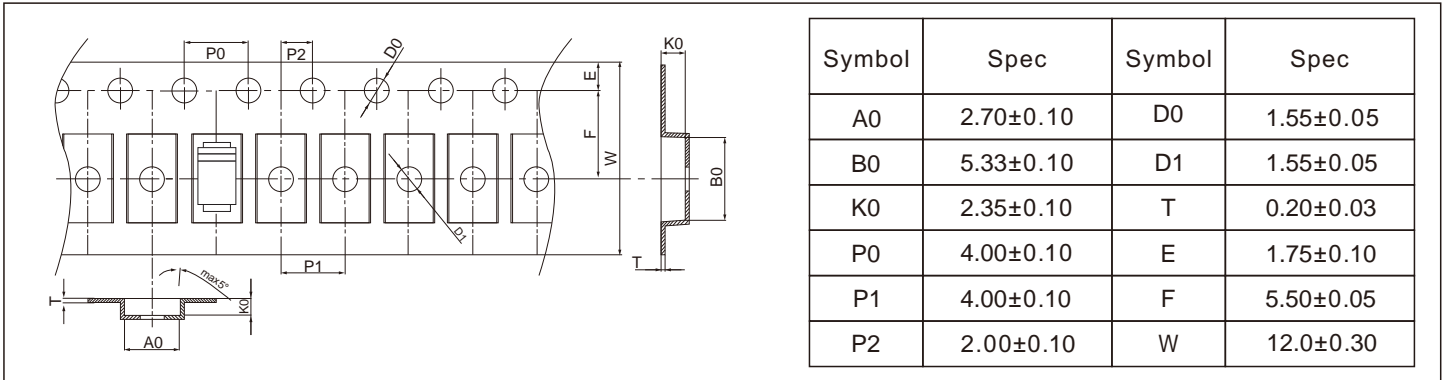

**Reel Dimensions**

Unit : mm

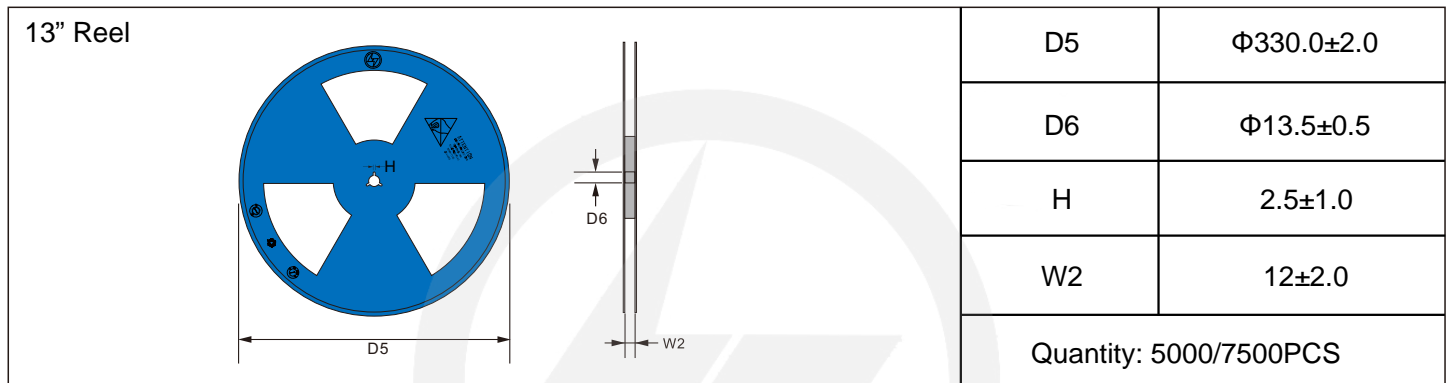

**Packaging**

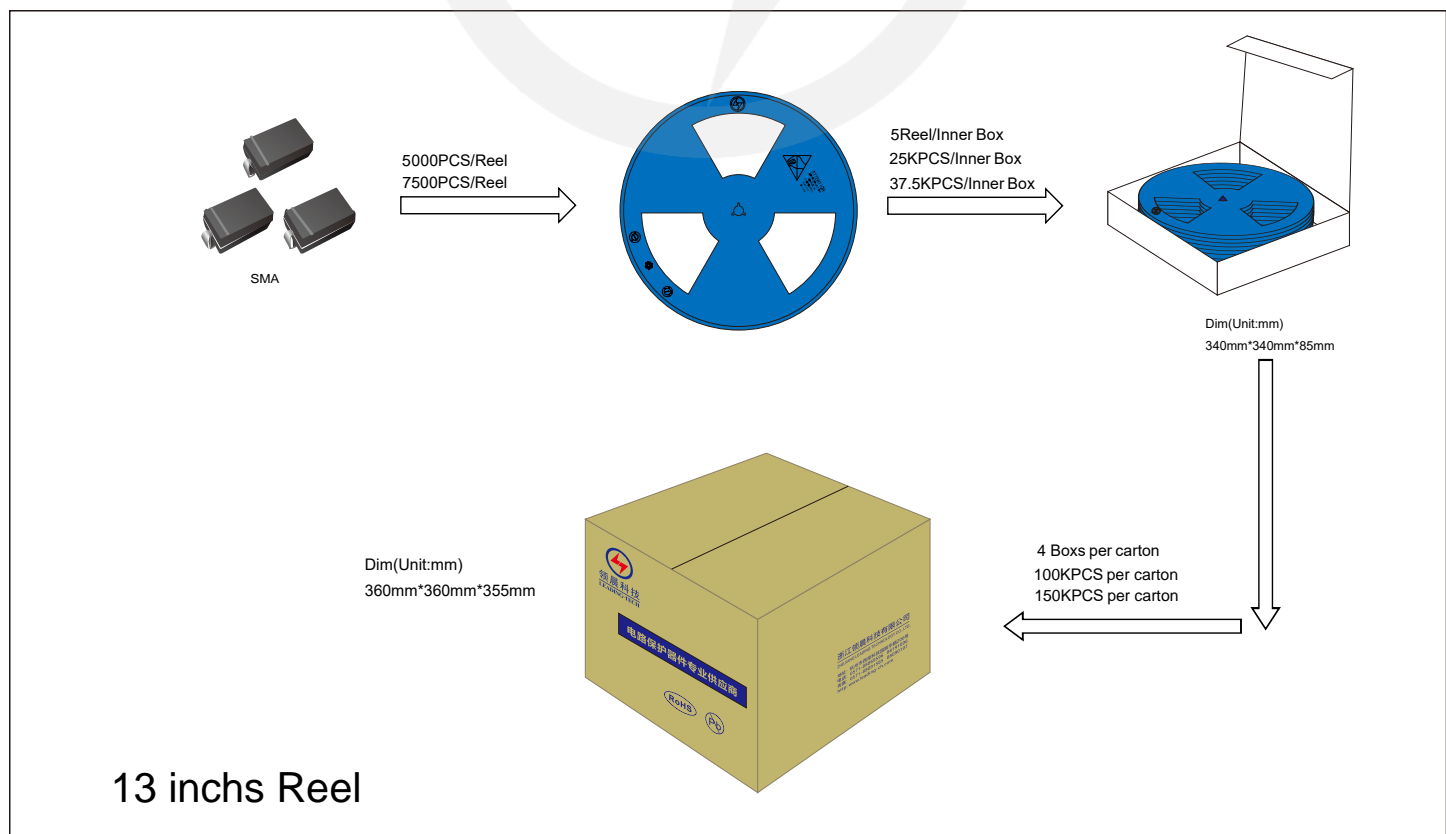

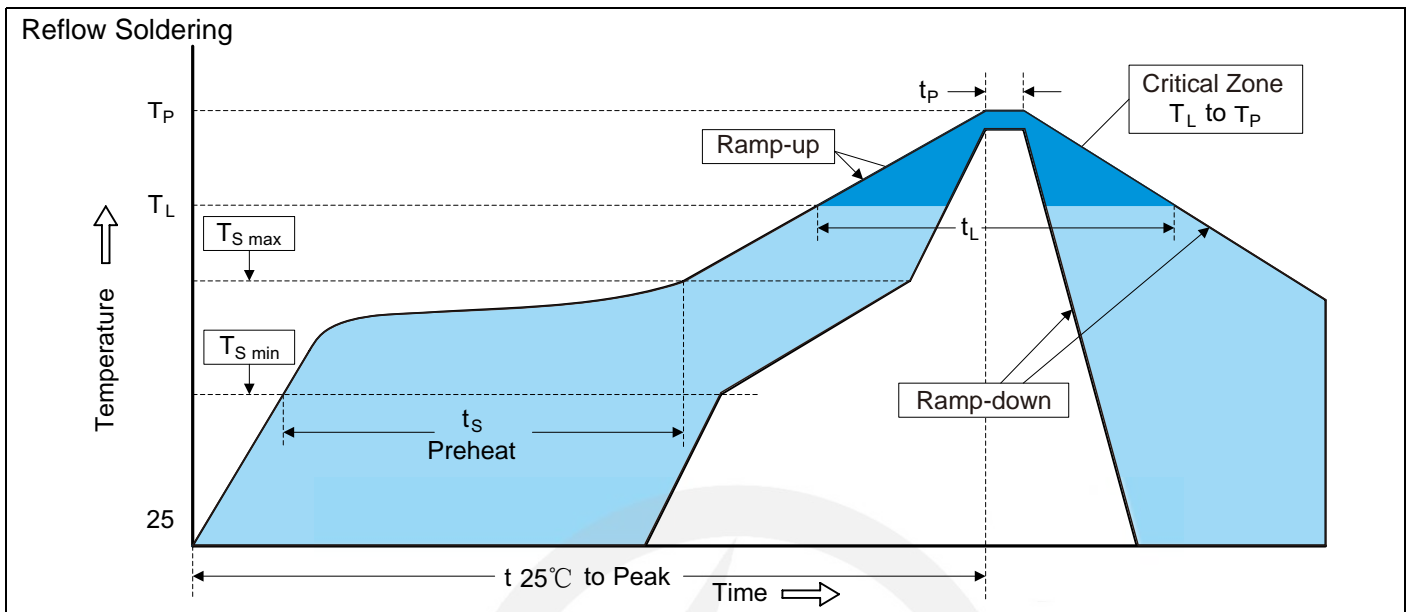
**Recommended Soldering Conditions**

**Recommended Conditions**

Profile Feature	Pb-Free Assembly
Average ramp-up rate ( $T_L$ to $T_P$ )	3°C/second max.
Preheat -Temperature Min ( $T_{S\ min}$ ) -Temperature Max ( $T_{S\ max}$ ) -Time (min to max) ( $t_s$ )	150°C 200°C 60-180 seconds
$T_{S\ max}$ to $T_L$ -Ramp-up Rate	3°C/second max.
Time maintained above: -Temperature ( $T_L$ ) -Time ( $t_L$ )	217°C 60-150 seconds
Peak Temperature ( $T_P$ )	260°C
Time within 5°C of actual Peak Temperature ( $t_P$ )	20-40 seconds
Ramp-down Rate	6°C/second max.
Time 25°C to Peak Temperature	8 minutes max.

## Important Notice and Disclaimer

Leading-Tech reserves the right to make changes to this document and its products and specifications at any time without notice.

Customers should obtain and confirm the latest product information and specifications before final design, purchase or use.

Leading-Tech makes no warranty, representation or guarantee regarding the suitability of its products for any particular purpose, not does Leading-Tech assume any liability for application assistance or customer product design.

Leading-tech does not warrant or accept any liability with products which are purchase or used for any unintended or unauthorized application.

No license is granted by implication or otherwise under any intellectual property rights of Leading-Tech.

Leading-Tech products are not authorized for use as critical components in life support devices or systems without express written approval of Leading-tech.

## Version Update information

Series NO.	Enactment/Revision Date	Effective Date	Version	Revision content	Revision Reason	Revision Person	Note
01	2024.12.06	2024.12.06	3.0	New File	/	Ding	