

## Transient Voltage Suppressors (TVS) Data Sheet

### Features

- 600W peak pulse power capability at 10/1000 $\mu$ s waveform, repetition rate (duty cycle): 0.01%
- Plastic package has underwriters laboratory flammability 94V-0
- Meets MSL level 1, per J-STD-020
- Typical  $I_R$  less than 1 $\mu$ A above 10V
- For surface mounted applications in order to optimize board space
- Low inductance
- Fast response time
- Low profile package
- Glass passivated junction
- Excellent clamping capability
- Lead free in comply with EU RoHS 2011/65/EU directives

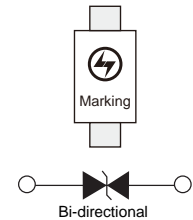
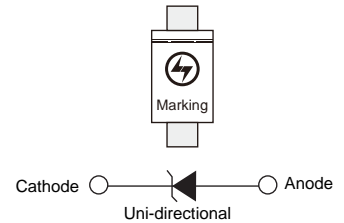
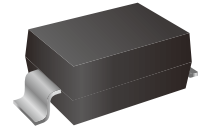

### Mechanical Data

- Case: SMAW
- Mounting Position: Any
- Terminal: Solder plated, solderable per MIL-STD-750, Method 2026
- Polarity: For uni-directional types the band denotes cathode end, no marking on bi-directional types

### Applications

- I/O interface
- AC/DC power supply
- Vcc bus
- Low frequency signal transmission line (RS232, RS485, etc.)

### Ordering Information

Part Number	Marking	Shipping	Reel
LTVxxA(C)J	See the Table	8000PCS Tape&Reel	13 inchs

### Maximum Ratings and Characteristics

Ratings at 25 $^{\circ}$ C ambient temperature unless otherwise specified.

Rating	Symbol	Value	Unit
Peak pulse power dissipation at 10/1000 $\mu$ s waveform (Note1, Note2, Fig.1)	$P_{PPM}$	Minimum 600	W
Peak pulse current of at 10/1000 $\mu$ s waveform (Note 1, Fig.3)	$I_{PPM}$	See Table	A
Steady state power dissipation at $T_A=50^{\circ}$ C (Fig.5)	$P_{M(AV)}$	5	W
Peak forward surge current, 8.3ms single half sine-wave superimposed on rated load, (JEDEC Method) (Note3, Fig.6)	$I_{FSM}$	100	A
Operating junction and Storage Temperature Range	$T_J, T_{STG}$	-55 to +150	$^{\circ}$ C
Typical thermal resistance junction to lead	$R_{\theta JL}$	20	$^{\circ}$ C/W
Typical thermal resistance junction to ambient	$R_{\theta JA}$	100	$^{\circ}$ C/W

Notes: (1) Non-repetitive current pulse, per Fig.3 and derated above  $T_A=25^{\circ}$ C per Fig.2.

(2) Mounted on 5.0mmx5.0mm (0.03mm thick) copper pads to each terminal.

(3) 8.3ms single half sine-wave, or equivalent square wave, duty cycle=4 pulses per minutes maximum, unidirectional only.



Electrical Characteristics (T<sub>A</sub>=25°C)

Part Number (Uni)	Part Number (Bi)	Marking	Reverse Stand off Voltage V <sub>r</sub> (Volts)	Breakdown Voltage V <sub>BR</sub> (Volts)@ I <sub>T</sub>		Test Current I <sub>T</sub> (mA)	Maximum Clamping Voltage V <sub>C</sub> @ I <sub>PP</sub> (V)	Maximum Peak Pulse Current I <sub>PP</sub> (A)	Maximum Reverse Leakage I <sub>R</sub> @ V <sub>R</sub> (μA)
				Min	Max				
LTV5.0AJ	LTV5.0CJ	5J	5.0	6.40	7.00	10	9.2	65.3	500
LTV6.0AJ	LTV6.0CJ	6J	6.0	6.67	7.37	10	10.3	58.3	500
LTV6.5AJ	LTV6.5CJ	6J5	6.5	7.22	7.98	10	11.2	53.6	300
LTV7.0AJ	LTV7.0CJ	7J	7.0	7.78	8.60	10	12.0	50.0	200
LTV7.5AJ	LTV7.5CJ	7J5	7.5	8.33	9.21	1	12.9	46.6	100
LTV8.0AJ	LTV8.0CJ	8J	8.0	8.89	9.83	1	13.6	44.2	50
LTV8.5AJ	LTV8.5CJ	8J5	8.5	9.44	10.40	1	14.4	41.7	20
LTV9.0AJ	LTV9.0CJ	9J	9.0	10.00	11.10	1	15.4	39.0	10
LTV10AJ	LTV10CJ	10J	10.0	11.10	12.30	1	17.0	35.3	5
LTV11AJ	LTV11CJ	11J	11.0	12.20	13.50	1	18.2	33.0	1
LTV12AJ	LTV12CJ	12J	12.0	13.30	14.70	1	19.9	30.2	1
LTV13AJ	LTV13CJ	13J	13.0	14.40	15.90	1	21.5	28.0	1
LTV14AJ	LTV14CJ	14J	14.0	15.60	17.20	1	23.2	25.9	1
LTV15AJ	LTV15CJ	15J	15.0	16.70	18.50	1	24.4	24.6	1
LTV16AJ	LTV16CJ	16J	16.0	17.80	19.70	1	26.0	23.1	1
LTV17AJ	LTV17CJ	17J	17.0	18.90	20.90	1	27.6	21.8	1
LTV18AJ	LTV18CJ	18J	18.0	20.00	22.10	1	29.2	20.6	1
LTV20AJ	LTV20CJ	20J	20.0	22.20	24.50	1	32.4	18.6	1
LTV22AJ	LTV22CJ	22J	22.0	24.40	26.90	1	35.5	16.9	1
LTV24AJ	LTV24CJ	24J	24.0	26.70	29.50	1	38.9	15.5	1
LTV26AJ	LTV26CJ	26J	26.0	28.90	31.90	1	42.1	14.3	1
LTV28AJ	LTV28CJ	28J	28.0	31.10	34.40	1	45.4	13.3	1
LTV30AJ	LTV30CJ	30J	30.0	33.30	36.80	1	48.4	12.4	1
LTV33AJ	LTV33CJ	33J	33.0	36.70	40.60	1	53.3	11.3	1
LTV36AJ	LTV36CJ	36J	36.0	40.00	44.20	1	58.1	10.4	1
LTV40AJ	LTV40CJ	40J	40.0	44.40	49.10	1	64.5	9.3	1
LTV43AJ	LTV43CJ	43J	43.0	47.80	52.80	1	69.4	8.7	1
LTV45AJ	LTV45CJ	45J	45.0	50.00	55.30	1	72.7	8.3	1
LTV48AJ	LTV48CJ	48J	48.0	53.30	58.90	1	77.4	7.8	1
LTV51AJ	LTV51CJ	51J	51.0	56.70	62.70	1	82.4	7.3	1
LTV54AJ	LTV54CJ	54J	54.0	60.00	66.30	1	87.1	6.9	1
LTV58AJ	LTV58CJ	58J	58.0	64.40	71.20	1	93.6	6.5	1
LTV60AJ	LTV60CJ	60J	60.0	66.70	73.70	1	96.8	6.2	1
LTV64AJ	LTV64CJ	64J	64.0	71.10	78.60	1	103.0	5.9	1
LTV70AJ	LTV70CJ	70J	70.0	77.80	86.00	1	113.0	5.3	1
LTV75AJ	LTV75CJ	75J	75.0	83.30	92.10	1	121.0	5.0	1
LTV78AJ	LTV78CJ	78J	78.0	86.70	95.80	1	126.0	4.8	1
LTV85AJ	LTV85CJ	85J	85.0	94.40	104.00	1	137.0	4.4	1
LTV90AJ	LTV90CJ	90J	90.0	100.00	111.00	1	146.0	4.1	1
LTV100AJ	LTV100CJ	100J	100.0	111.00	123.00	1	162.0	3.7	1
LTV110AJ	LTV110CJ	110J	110.0	122.00	135.00	1	177.0	3.4	1
LTV120AJ	LTV120CJ	120J	120.0	133.00	147.00	1	193.0	3.1	1
LTV130AJ	LTV130CJ	130J	130.0	144.00	159.00	1	209.0	2.9	1
LTV150AJ	LTV150CJ	150J	150.0	167.00	185.00	1	243.0	2.5	1
LTV160AJ	LTV160CJ	160J	160.0	178.00	197.00	1	259.0	2.3	1
LTV170AJ	LTV170CJ	170J	170.0	189.00	209.00	1	275.0	2.2	1
LTV180AJ	LTV180CJ	180J	180.0	201.00	222.00	1	292.0	2.1	1
LTV190AJ	LTV190CJ	190J	190.0	211.00	233.00	1	308.0	2.0	1
LTV200AJ	LTV200CJ	200J	200.0	224.00	247.00	1	324.0	1.9	1
LTV210AJ	LTV210CJ	210J	210.0	237.00	263.00	1	340.0	1.8	1
LTV220AJ	LTV220CJ	220J	220.0	246.00	272.00	1	356.0	1.7	1

Notes: For bidirectional type having V<sub>r</sub> of 10V and less, the I<sub>R</sub> limit is double.

## Characteristics Curves ( $T_A=25^\circ\text{C}$ unless otherwise noted)

**FIG.1 PEAK PULSE POWER RATING CURVE**

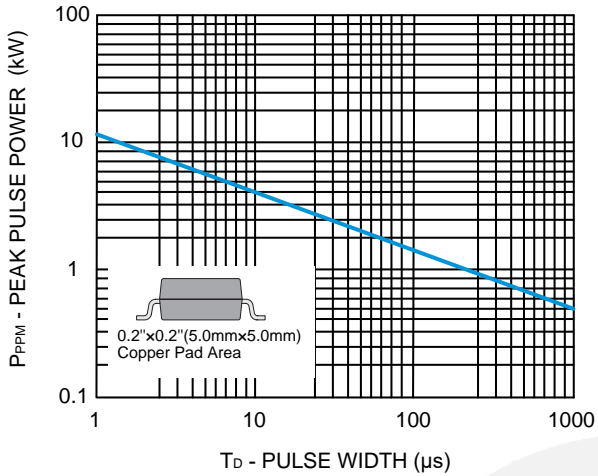

**FIG.2 PULSE DERATING CURVE**

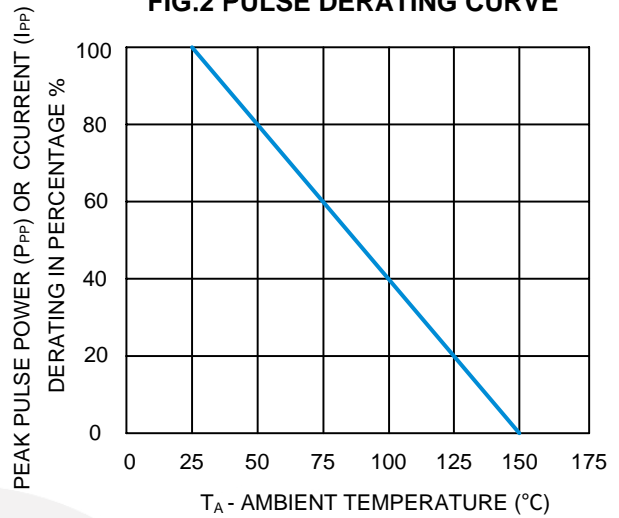

**FIG.3 PULSE WAVEFORM**

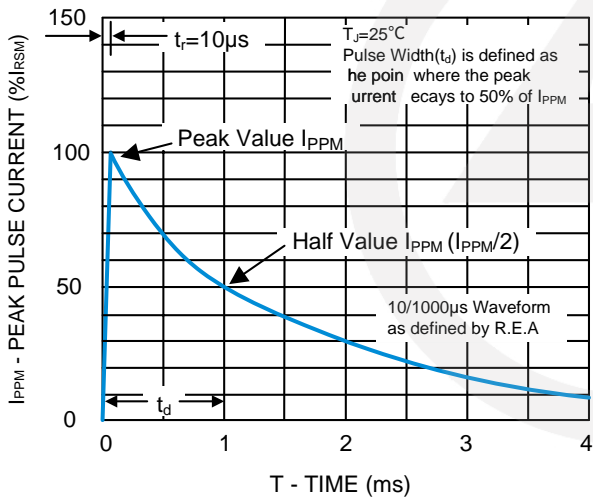

**FIG.4 TYPICAL JUNCTION CAPACITANCE**

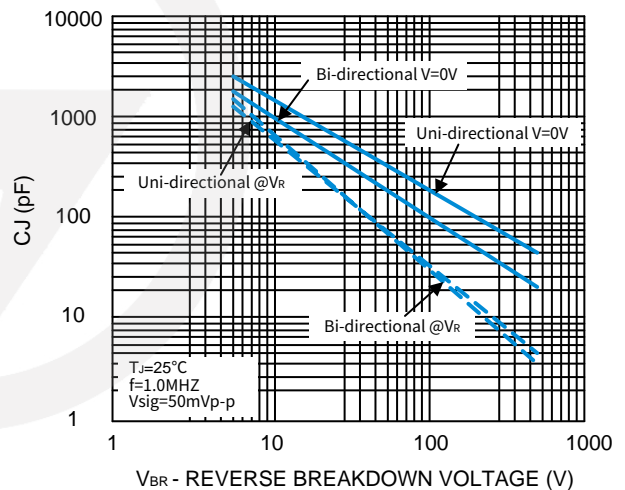

**FIG.5 STEADY STATE POWER DISSIPATION DERATING CURVE**

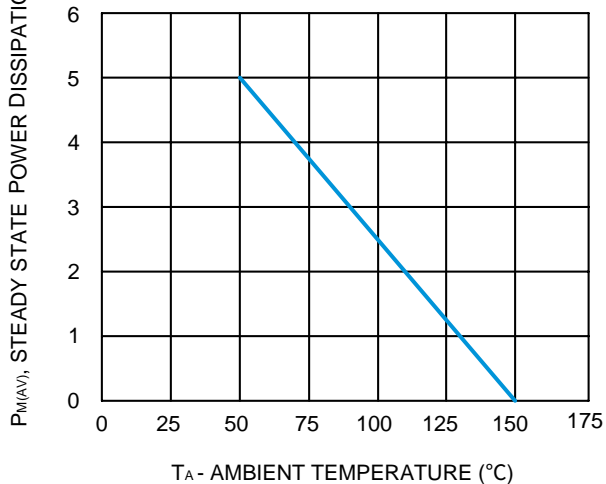

**FIG.6 MAXIMUM NON-REPETITIVE FORWARD SURGE CURRENT UNI-DIRECTIONAL ONLY**

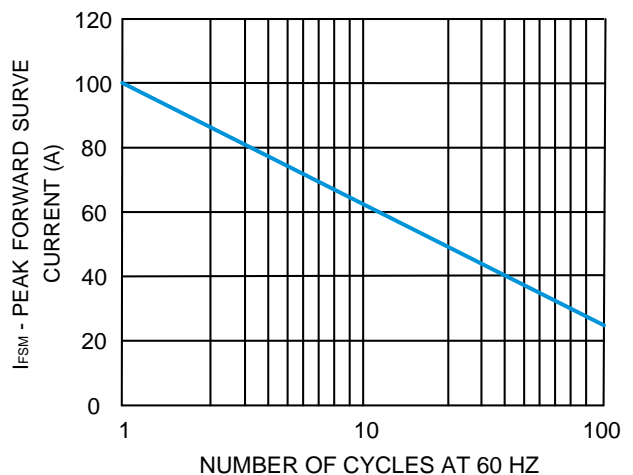

## Package Outline

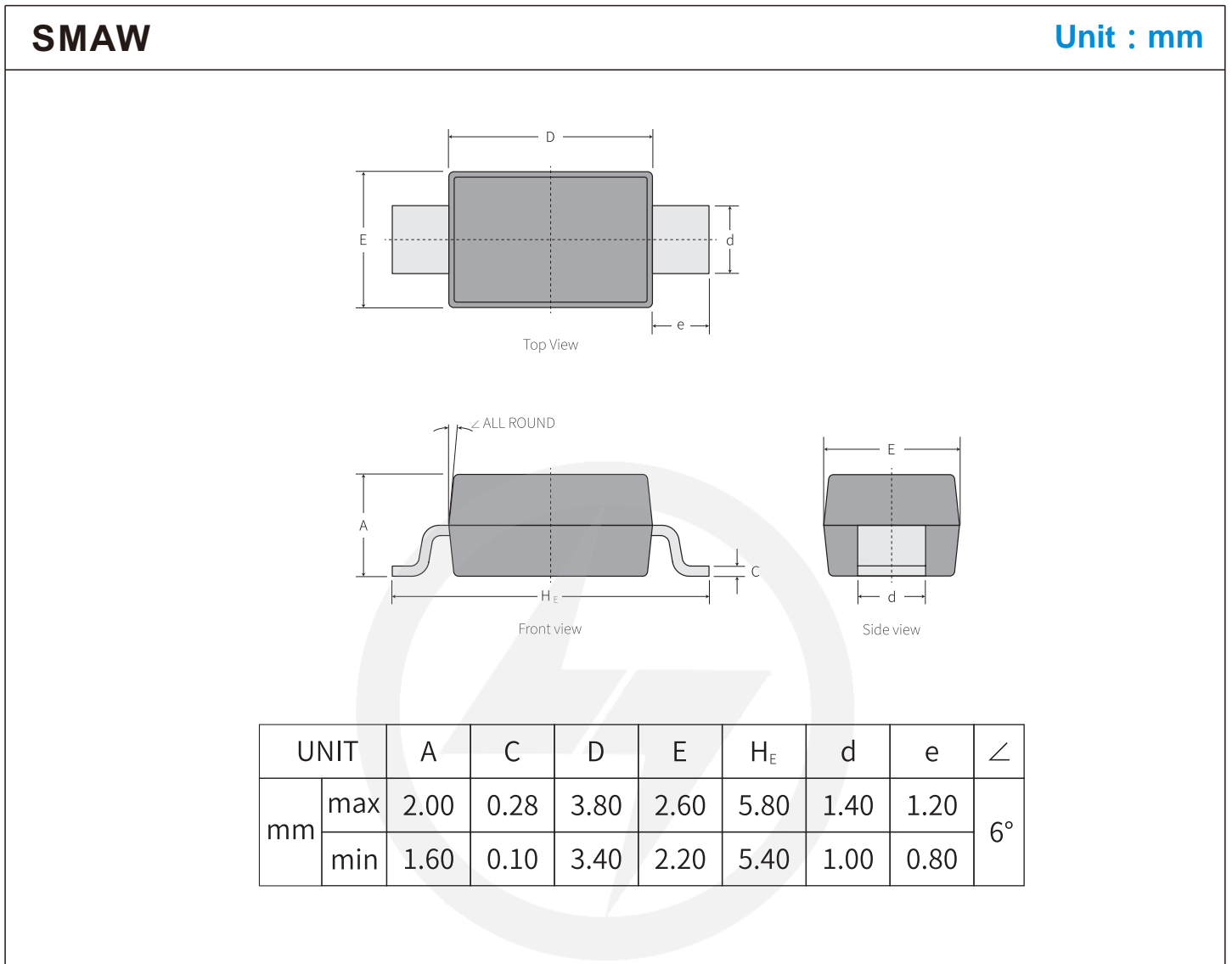

## Suggested Pad Layout

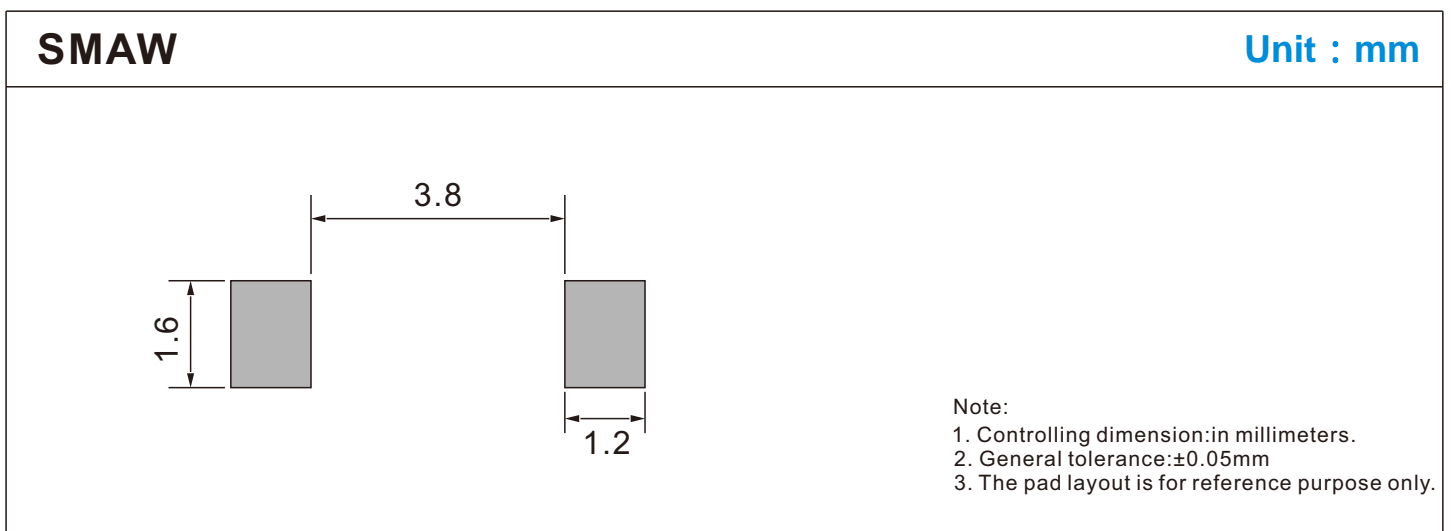

## Carrier Tape Dimensions

Unit : mm

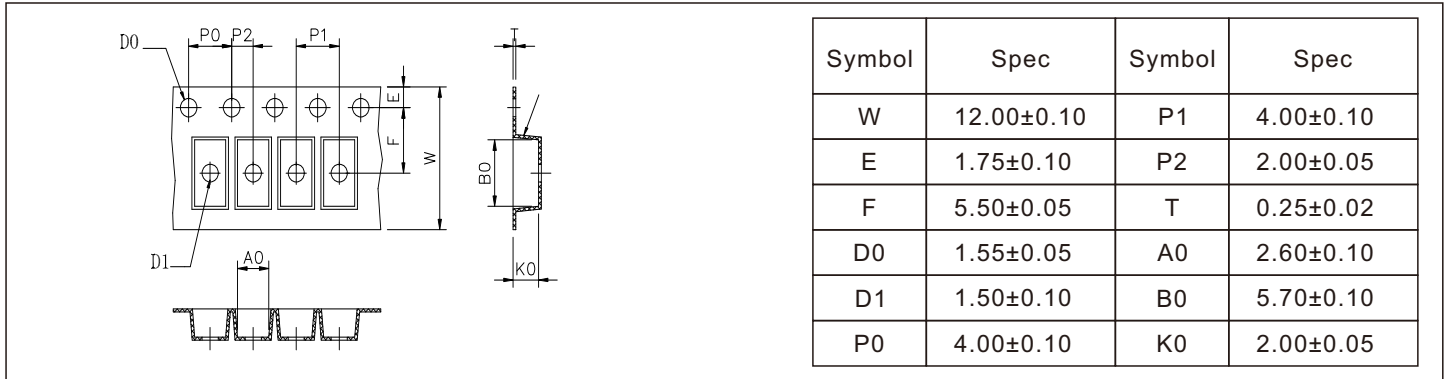

## Reel Dimensions

Unit : mm

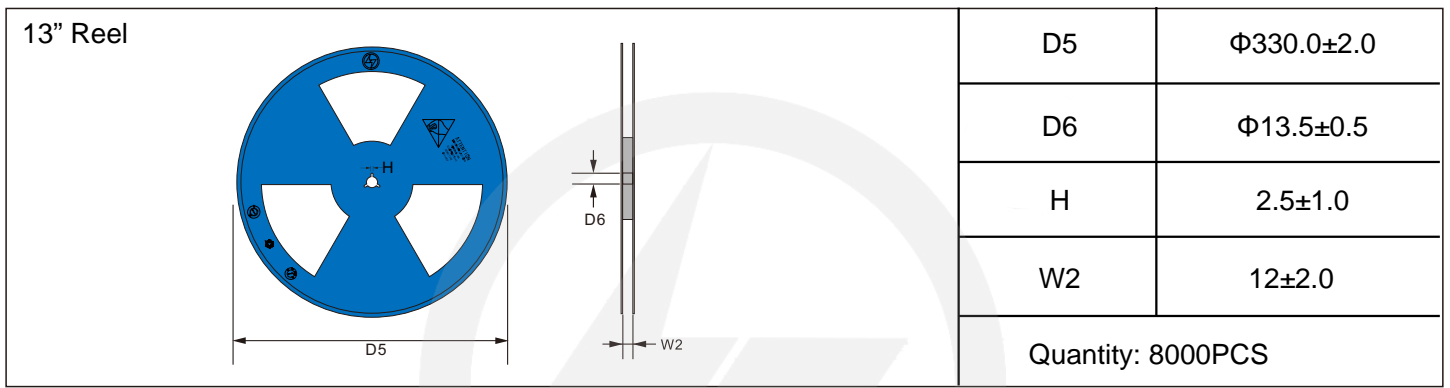

## Packaging

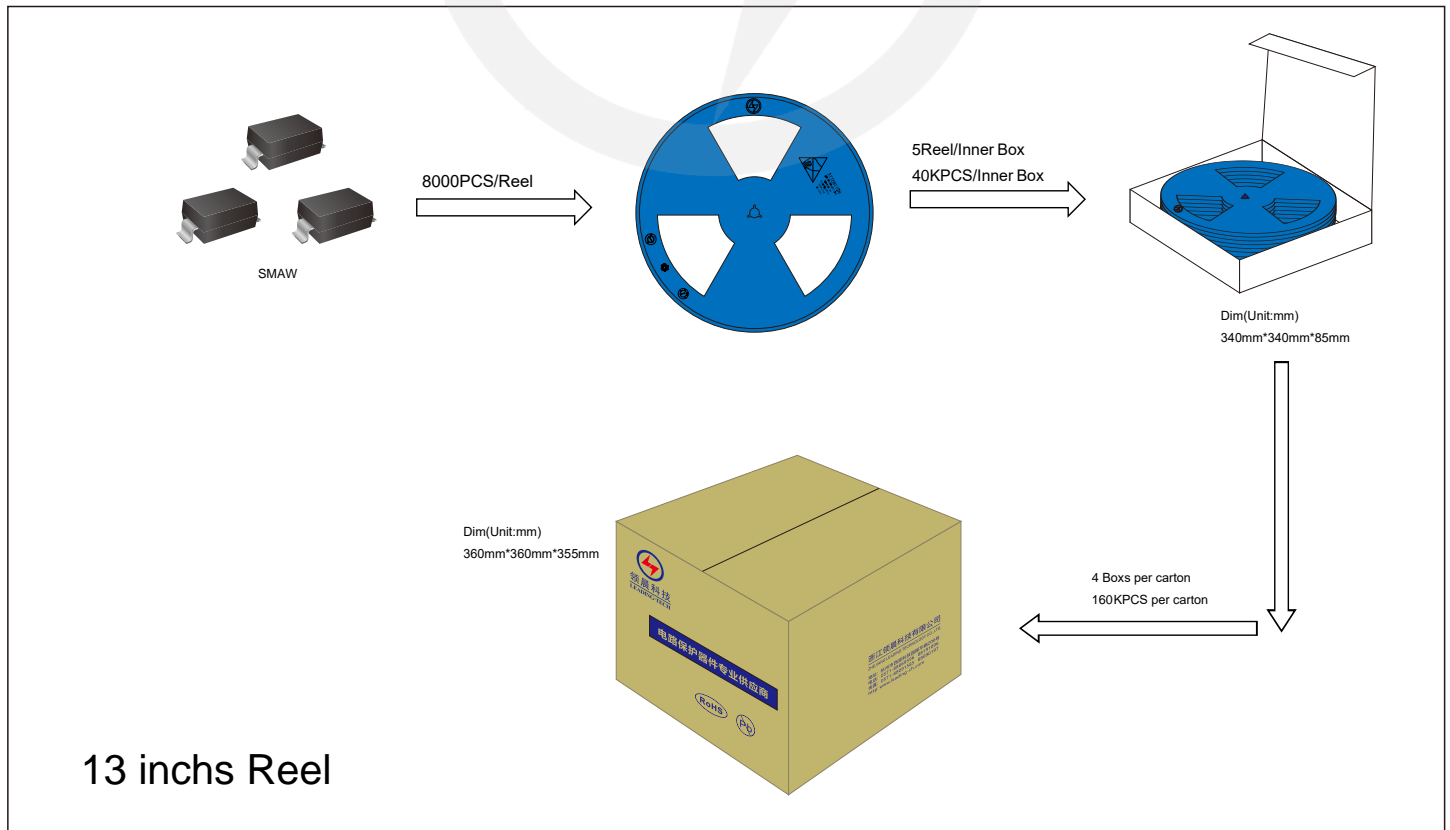



Recommended Soldering Conditions



Recommended Conditions

Profile Feature	Pb-Free Assembly
Average ramp-up rate (T <sub>L</sub> to T <sub>P</sub> )	3°C/second max.
Preheat	
-Temperature Min (T <sub>S min</sub> )	150°C
-Temperature Max (T <sub>S max</sub> )	200°C
-Time (min to max) (t <sub>s</sub> )	60-180 seconds
T <sub>S max</sub> to T <sub>L</sub>	
-Ramp-up Rate	3°C/second max.
Time maintained above:	
-Temperature (T <sub>L</sub> )	217°C
-Time (t <sub>L</sub> )	60-150 seconds
Peak Temperature (T <sub>P</sub> )	260°C
Time within 5°C of actual Peak Temperature (t <sub>p</sub> )	20-40 seconds
Ramp-down Rate	6°C/second max.
Time 25°C to Peak Temperature	8 minutes max.

## Important Notice and Disclaimer

Leading-Tech reserves the right to make changes to this document and its products and specifications at any time without notice.

Customers should obtain and confirm the latest product information and specifications before final design, purchase or use.

Leading-Tech makes no warranty, representation or guarantee regarding the suitability of its products for any particular purpose, not does Leading-Tech assume any liability for application assistance or customer product design.

Leading-tech does not warrant or accept any liability with products which are purchase or used for any unintended or unauthorized application.

No license is granted by implication or otherwise under any intellectual property rights of Leading-Tech.

Leading-Tech products are not authorized for use as critical components in life support devices or systems without express written approval of Leading-tech.

## Version Update Information

Series NO.	Enactment/Revision Date	Effective Date	Version	Revision content	Revision Reason	Revision Person	Note
01	2023.11.29	2023.11.29	1.0	New File	/	Ding	
02	2025.06.27	2025.06.27	1.1	T <sub>J</sub> , T <sub>STG</sub> Change to -55 to +150°C	/	Ding	