

Transient Voltage Suppressors (TVS) Data Sheet

Features

- For surface mounted applications in order to optimize board space
- Low profile package
- Glass passivated junction
- Low inductance
- Plastic package has Underwriters Laboratory Flammability
- Lead free in comply with EU RoHS 2011/65/EU directives

Mechanical Data

- Case: SOD-123FL
- Terminals: Solderable per MIL-STD-750, Method 2026
- Polarity: For uni-directional types the band denotes cathode end, no marking on bi-directional types

Ordering Information

Part Number	Shipping	Reel
LTVLxxA(C)D-TR3	3000PCS Tape&Reel	7 inches
LTVLxxA(C)D-TR12	12000PCS Tape&Reel	13 inches

Maximum Ratings and Characteristics

Ratings at 25 °C ambient temperature unless otherwise specified.

Parameter	Symbol	Value	Unit
Peak Pulse Power Dissipation on TA=25°C (Note1,2,5, Fig1)	P_{PPM}	200	W
Peak Forward Surge Current (Note3)	I_{FSM} (UNI)	20	A
Peak Pulse Current on 10/1000 us waveform (Note1 Fig 2)	I_{PPM}	see Table 1	A
Steady State Power Dissipation (Note4)	$P_{M(AV)}$	1	W
Operating Junction and Storage Range	T_J, T_{STG}	-55 to +150	°C
Typical Thermal Resistance (Note6)	$R_{\theta JA}$	180	°C/W

Note: (1) Non-repetitive current pulse per Fig 3 and derated above $T_a=25^\circ\text{C}$ per Fig 2

(2) Mounted on 5mm² copper pads to each terminal

(3) 8.3ms single half sinewave, or equivalent square wave duty cycle=4 pulses per minutes maximum, unidirectional only

(4) lead temperature at $T_L=75^\circ\text{C}$

(5) Peak pulse powe. waveform is $t_p=10/1000\mu\text{s}$

(6) P.C.B. mounted with 0.2" x 0.2" (5mm x 5mm) copper pad areas.

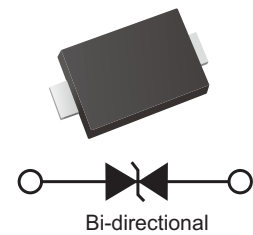
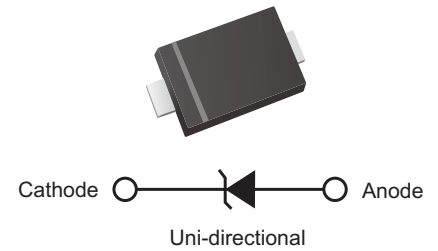



Electrical Characteristics (TA=25°C)

Part Number (Uni)	Part Number (Bi)	Marking		Reverse Stand off Voltage V_R (Volts)	Breakdown Voltage V_{BR} (Volts)@ I_T		Test Current I_T (mA)	Maximum Clamping Voltage V_C @ I_{PP} (V)	Maximum Peak Pulse Current I_{PP} (A)	Maximum Reverse Leakage I_R @ V_R (μA)
		UNI	BI		MIN	MAX				
LTVL5.0AD	LTVL5.0CD	5A	5C	5	6.4	7	10	9.2	21.7	400
LTVL6.0AD	LTVL6.0CD	6A	6C	6	6.67	7.37	10	10.3	19.4	400
LTVL6.5AD	LTVL6.5CD	6A5	6C5	6.5	7.22	7.98	10	11.2	17.9	250
LTVL7.0AD	LTVL7.0CD	7A	7C	7	7.78	8.6	10	12	16.7	100
LTVL7.5AD	LTVL7.5CD	7A5	7C5	7.5	8.33	9.21	1	12.9	15.5	50
LTVL8.0AD	LTVL8.0CD	8A	8C	8	8.89	9.83	1	13.6	14.7	25
LTVL8.5AD	LTVL8.5CD	8A5	8C5	8.5	9.44	10.4	1	14.4	13.9	10
LTVL9.0AD	LTVL9.0CD	9A	9C	9	10	11.1	1	15.4	13.0	5
LTVL10AD	LTVL10CD	10A	10C	10	11.1	12.3	1	17	11.8	2.5
LTVL11AD	LTVL11CD	11A	11C	11	12.2	13.5	1	18.2	11.0	2.5
LTVL12AD	LTVL12CD	12A	12C	12	13.3	14.7	1	19.9	10.1	2.5
LTVL13AD	LTVL13CD	13A	13C	13	14.4	15.9	1	21.5	9.3	1
LTVL14AD	LTVL14CD	14A	14C	14	15.6	17.2	1	23.2	8.6	1
LTVL15AD	LTVL15CD	15A	15C	15	16.7	18.5	1	24.4	8.2	1
LTVL16AD	LTVL16CD	16A	16C	16	17.8	19.7	1	26	7.7	1
LTVL17AD	LTVL17CD	17A	17C	17	18.9	20.9	1	27.6	7.2	1
LTVL18AD	LTVL18CD	18A	18C	18	20	22.1	1	29.2	6.8	1
LTVL20AD	LTVL20CD	20A	20C	20	22.2	24.5	1	32.4	6.2	1
LTVL22AD	LTVL22CD	22A	22C	22	24.4	26.9	1	35.5	5.6	1
LTVL24AD	LTVL24CD	24A	24C	24	26.7	29.5	1	38.9	5.1	1
LTVL26AD	LTVL26CD	26A	26C	26	28.9	31.9	1	42.1	4.8	1
LTVL28AD	LTVL28CD	28A	28C	28	31.1	34.4	1	45.4	4.4	1
LTVL30AD	LTVL30CD	30A	30C	30	33.3	36.8	1	48.4	4.1	1
LTVL33AD	LTVL33CD	33A	33C	33	36.7	40.6	1	53.3	3.8	1
LTVL36AD	LTVL36CD	36A	36C	36	40	44.2	1	58.1	3.4	1
LTVL40AD	LTVL40CD	40A	40C	40	44.4	49.1	1	64.5	3.1	1
LTVL43AD	LTVL43CD	43A	43C	43	47.8	52.8	1	69.4	2.9	1
LTVL45AD	LTVL45CD	45A	45C	45	50	55.3	1	72.7	2.8	1
LTVL48AD	LTVL48CD	48A	48C	48	53.3	58.9	1	77.4	2.6	1
LTVL51AD	LTVL51CD	51A	51C	51	56.7	62.7	1	82.4	2.4	1
LTVL54AD	LTVL54CD	54A	54C	54	60	66.3	1	87.1	2.3	1
LTVL58AD	LTVL58CD	58A	58C	58	64.4	71.2	1	93.6	2.1	1
LTVL60AD	LTVL60CD	60A	60C	60	66.7	73.7	1	96.8	1.8	1
LTVL64AD	LTVL64CD	64A	64C	64	71.1	78.6	1	103	1.7	1
LTVL70AD	LTVL70CD	70A	70C	70	77.8	86	1	113	1.5	1
LTVL75AD	LTVL75CD	75A	75C	75	83.3	92.1	1	121	1.4	1
LTVL78AD	LTVL78CD	78A	78C	78	86.7	95.8	1	126	1.4	1
LTVL85AD	LTVL85CD	85A	85C	85	94.4	104	1	137	1.3	1
LTVL90AD	LTVL90CD	90A	90C	90	100	111	1	146	1.2	1
LTVL100AD	LTVL100CD	100A	100C	100	111	123	1	162	1.1	1
LTVL110AD	LTVL110CD	110A	110C	110	122	135	1	177	1.0	1
LTVL120AD	LTVL120CD	120A	120C	120	133	147	1	193	0.9	1
LTVL130AD	LTVL130CD	130A	130C	130	144	159	1	209	0.8	1
LTVL150AD	LTVL150CD	150A	150C	150	167	185	1	243	0.7	1
LTVL160AD	LTVL160CD	160A	160C	160	178	197	1	259	0.7	1
LTVL170AD	LTVL170CD	170A	170C	170	189	209	1	275	0.6	1



Electrical Characteristics Curve

Fig.1 Peak Pulse Power Rating Curve

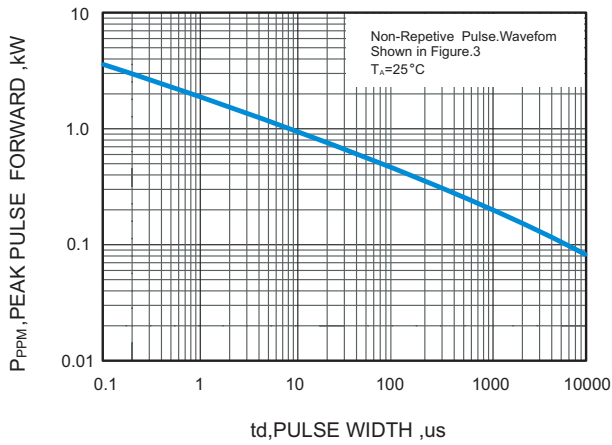

Fig.2 Forward Current Derating Curve

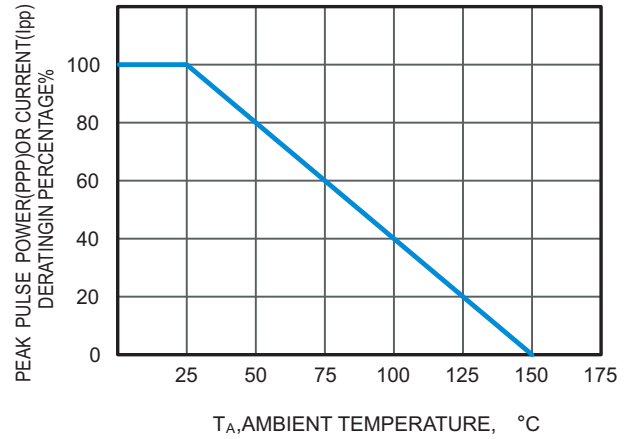

Fig.3 Pulse Waveform

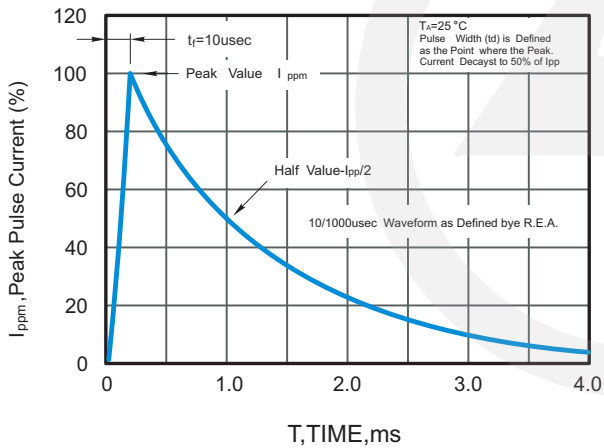
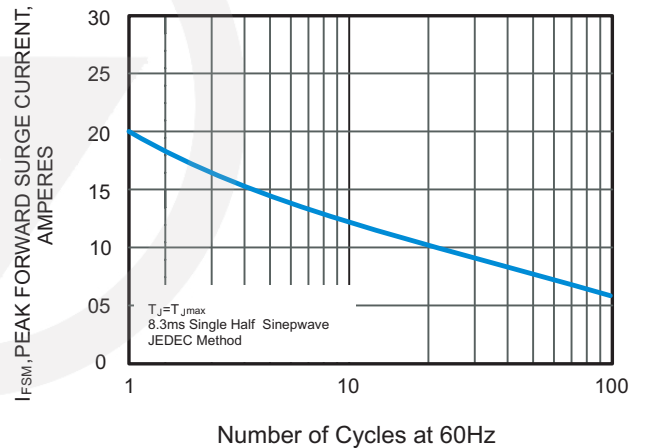
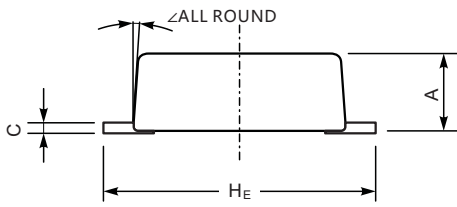

Fig.4 Maximum Non-Repetitive Peak Forward Surge Current



SOD-123FL Package Outline

Unit: mm



SYMBOL	DIMENSIONS	
	MIN.	MAX.
A	0.9	1.35
C	0.12	0.20
D	2.6	2.9
E	1.75	1.95
e	0.8	1.1
g	0.7	0.9
H _E	3.5	3.8
∠	7°	

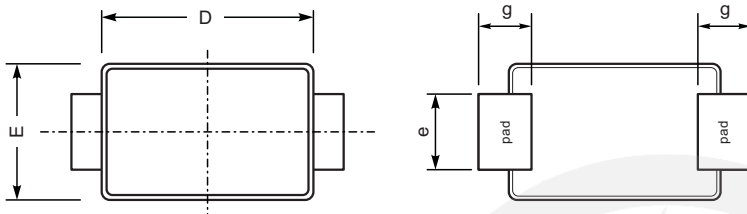

SOD-123FL Suggested Pad Layout

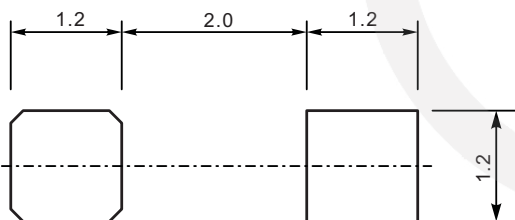

- Note:
1. Controlling dimension: in millimeters.
 2. General tolerance: $\pm 0.05\text{mm}$
 3. The pad layout is for reference purpose only.

Carrier Tape Dimensions

Unit : mm

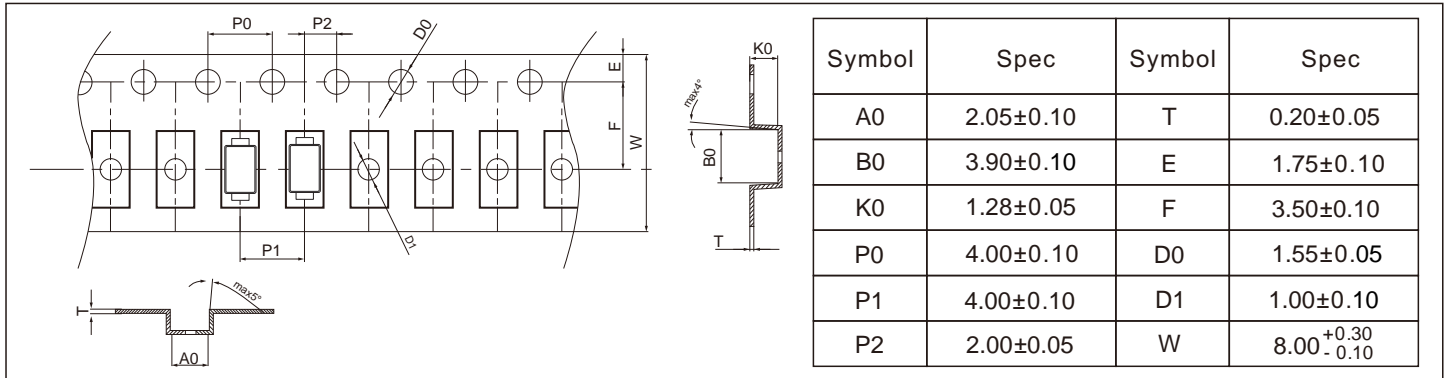

Reel Dimensions

Unit : mm

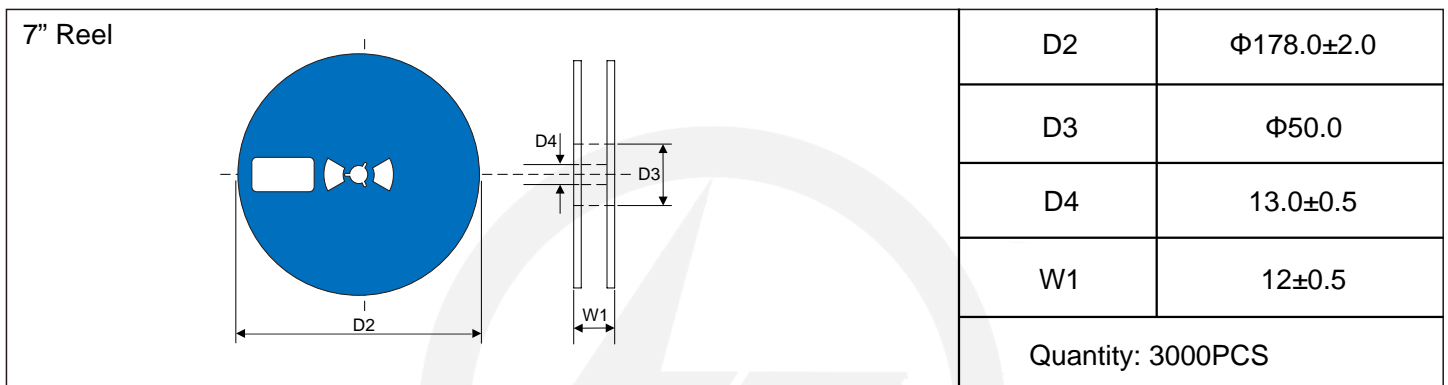

Reel Dimensions

Unit : mm

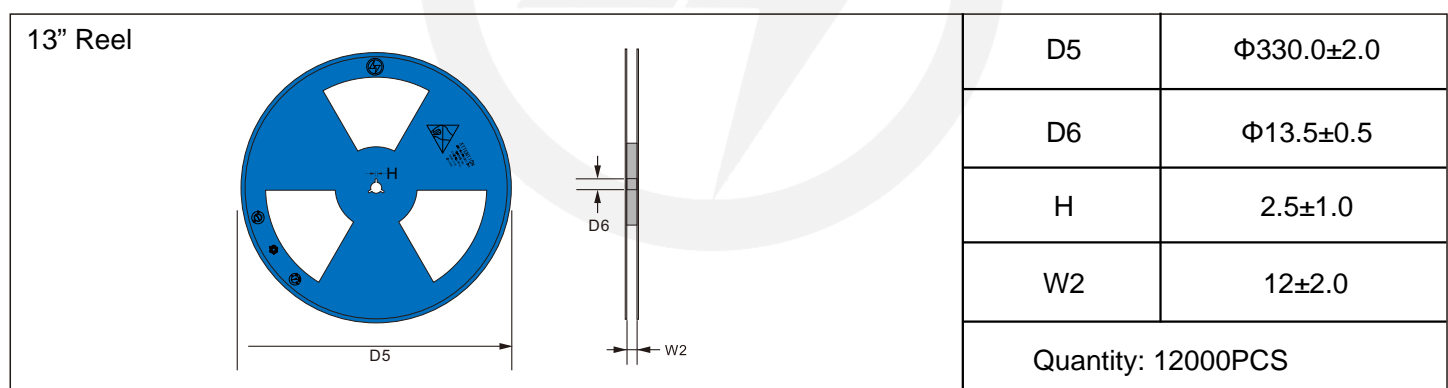

Packaging

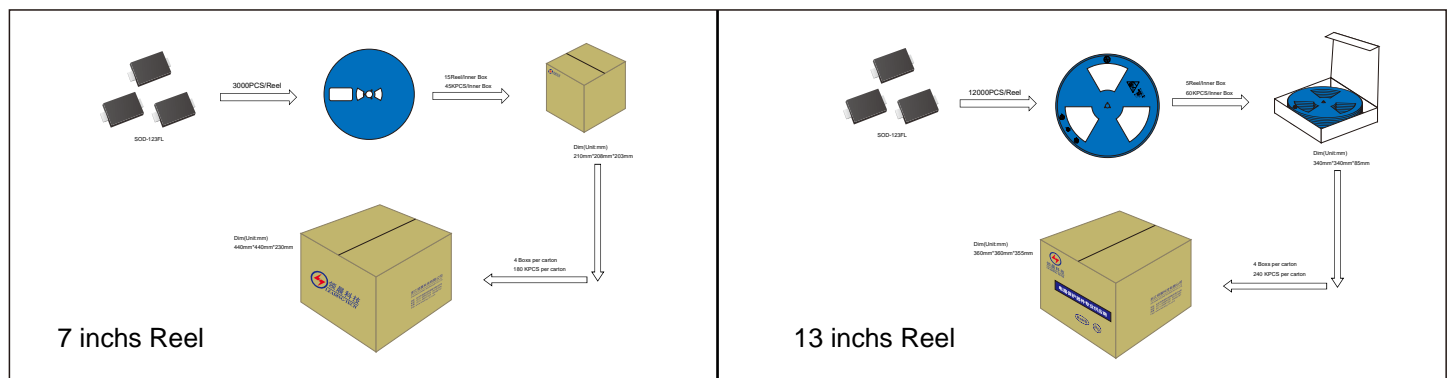

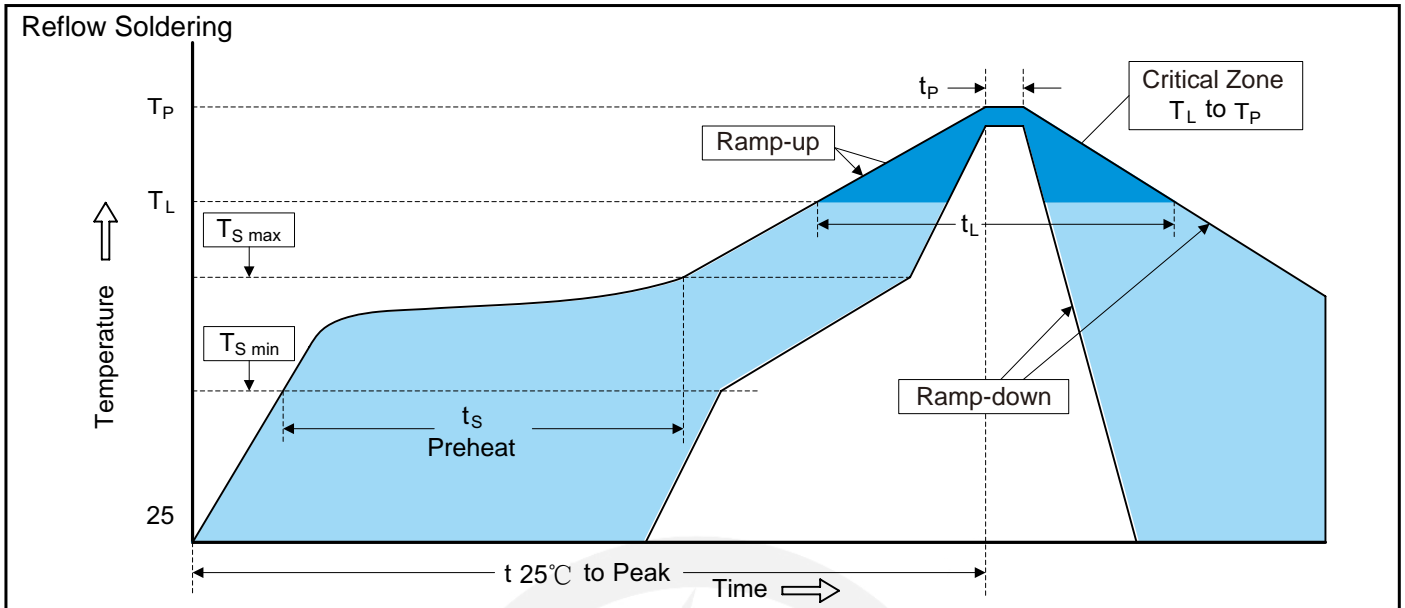
Recommended Soldering Conditions

Recommended Conditions

Profile Feature	Pb-Free Assembly
Average ramp-up rate (T _L to T _P)	3°C/second max.
Preheat	
-Temperature Min (T _{S min})	150°C
-Temperature Max (T _{S max})	200°C
-Time (min to max) (t _s)	60-180 seconds
T _{S max} to T _L	
-Ramp-up Rate	3°C/second max.
Time maintained above:	
-Temperature (T _L)	217°C
-Time (t _L)	60-150 seconds
Peak Temperature (T _P)	260°C
Time within 5°C of actual Peak Temperature (t _P)	20-40 seconds
Ramp-down Rate	6°C/second max.
Time 25°C to Peak Temperature	8 minutes max.

Important Notice and Disclaimer

Leading-Tech reserves the right to make changes to this document and its products and specifications at any time without notice.

Customers should obtain and confirm the latest product information and specifications before final design, purchase or use.

Leading-Tech makes no warranty, representation or guarantee regarding the suitability of its products for any particular purpose, not does Leading-Tech assume any liability for application assistance or customer product design.

Leading-tech does not warrant or accept any liability with products which are purchase or used for any unintended or unauthorized application.

No license is granted by implication or otherwise under any intellectual property rights of Leading-Tech.

Leading-Tech products are not authorized for use as critical components in life support devices or systems without express written approval of Leading-tech.

Version Update Information

Series NO.	Enactment/Revision Date	Effective Date	Version	Revision content	Revision Reason	Revision Person	Note
01	2024.4.14	2024.4.14	3.0	New File	/	Ding	
02	2025.06.12	2025.06.12	3.1	Update packaging information	/	Ding	