

## Transient Voltage Suppressors (TVS) Data Sheet

### Features

- For surface mounted applications in order to optimize board space
- 600W peak pulse power capability at 10/1000 $\mu$ s waveform, repetition rate (duty cycle): 0.01%
- Typical  $I_R$  less than 1 $\mu$ A above 10V
- Low profile package
- Built-in strain relief
- Glass passivated junction
- Low inductance
- Excellent clamping capability
- Fast response time
- Plastic package has underwriters laboratory flammability 94V-0
- Meets MSL level 1, per J-STD-020
- Lead free in comply with EU RoHS 2011/65/EU directives

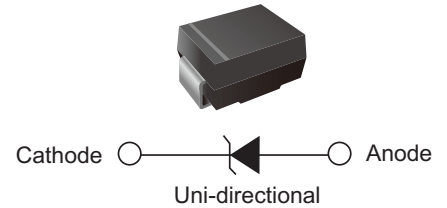

### Mechanical Data

- Case: SMB
- Terminals: Solderable per MIL-STD-750, Method 2026
- Polarity: Color band denotes cathode end
- Approx. Weight: 0.1g

### Applications

- I/O interface
- Vcc bus
- AC/DC power supply
- Low frequency signal transmission line (RS232, RS485, etc.)

### Ordering Information

Part Number	Shipping	Reel
LTVB200AJ-TR3	3000PCS Tape&Reel	13 inches

### Maximum Ratings and Characteristics

Ratings at 25 $^{\circ}$ C ambient temperature unless otherwise specified.

Rating	Symbol	Value	Units
Peak pulse power dissipation at 10/1000 $\mu$ s waveform (Note1, Note2, Fig.1)	$P_{PPM}$	Minimum 600	W
Peak pulse current of at 10/1000 $\mu$ s waveform (Note 1, Fig.3)	$I_{PPM}$	See Table	A
Steady state power dissipation at $T_A=50^{\circ}$ C (Fig.5)	$P_{M(AV)}$	5.0	W
Peak forward surge current, 8.3ms single half sine-wave superimposed on rated load, (JEDEC Method) (Note3, Fig.6)	$I_{FSM}$	100	A
Operating junction and Storage Temperature Range.	$T_J, T_{STG}$	-55 to +150	$^{\circ}$ C
Typical thermal resistance junction to lead	$R_{\theta JL}$	20	$^{\circ}$ C/W
Typical thermal resistance junction to ambient	$R_{\theta JA}$	100	$^{\circ}$ C/W

- Notes: 1. Non-repetitive current pulse, per Fig.3 and derated above  $T_A=25^{\circ}$ C per Fig.2.  
 2. Mounted on 5.0mm $\times$ 5.0mm (0.03mm thick) copper pads to each terminal.  
 3. 8.3ms single half sine-wave, or equivalent square wave, duty cycle=4 pulses per minutes maximum.

**Electrical Characteristics ( $T_A=25^\circ\text{C}$ )**

Part Number (Bi)	Marking	Reverse Stand off Voltage $V_R$ (Volts)	Breakdown Voltage $V_{BR}$ (Volts)@ $I_T$		Test Current $I_T$ (mA)	Maximum Clamping Voltage $V_C$ @ $I_{PP}$ (V)	Maximum Peak Pulse Current $I_{PP}$ (A)	Maximum Reverse Leakage $I_R$ @ $V_R$ ( $\mu\text{A}$ )
			Min	Max				
LTVB200AJ	SMBJ 200A	200	224	247	1	324	1.9	1

Notes: For bidirectional type having  $V_R$  of 10V and less, the  $I_R$  limit is double.

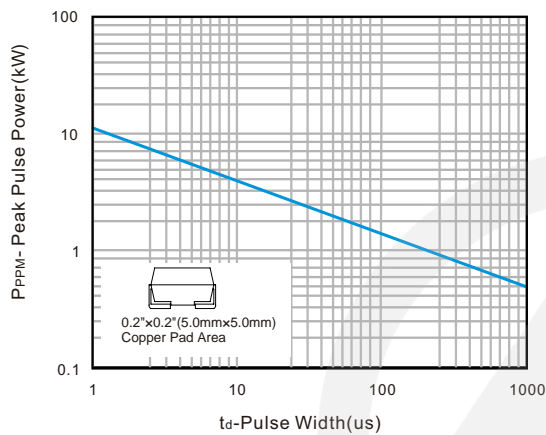
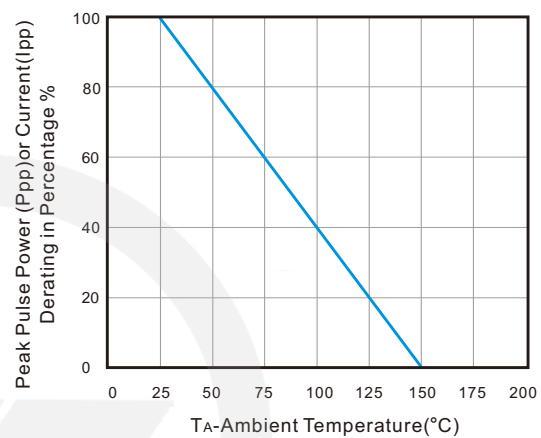
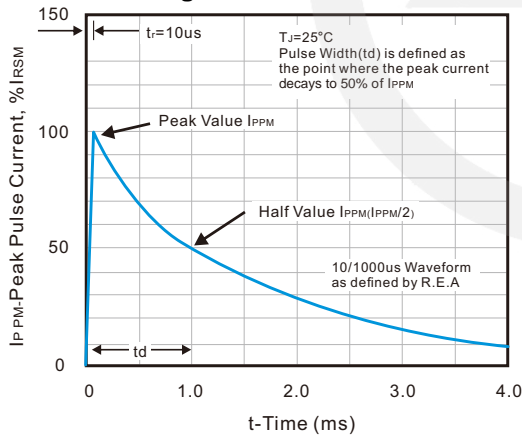
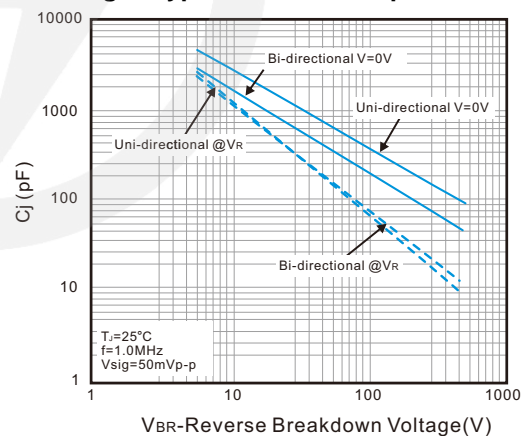
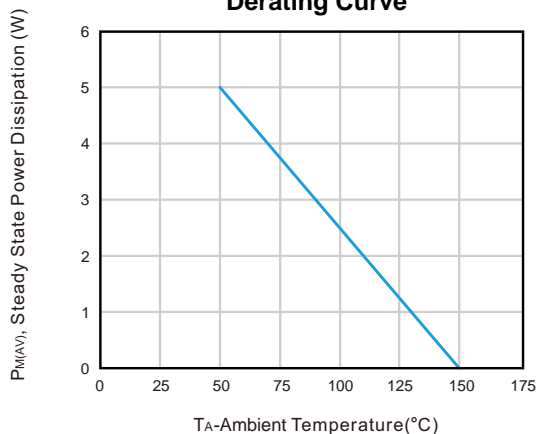
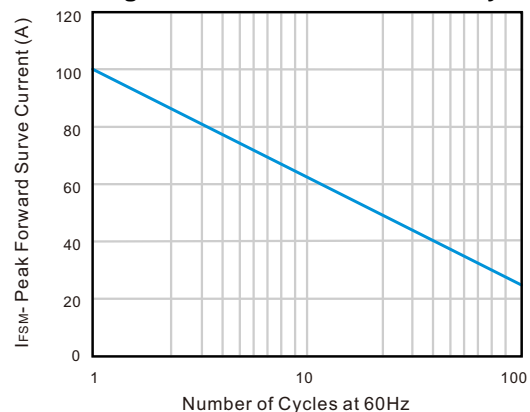
**Characteristics Curves ( $T_A = 25^\circ\text{C}$  unless otherwise noted)**
**Fig.1 Peak Pulse Power Rating Curve**

**Fig.2 Pulse Derating Curve**

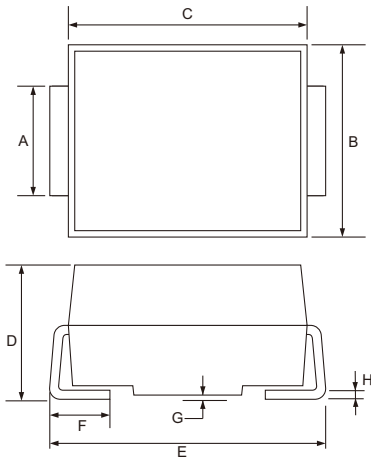
**Fig.3 Pulse Waveform**

**Fig.4 Typical Junction Capacitance**

**Fig.5 Steady State Power Dissipation Derating Curve**

**Fig.6 Maximum Non-Repetitive Forward Surge Current Uni-Directional Only**

**SMB Package Outline**



Unit: mm

SYMBOL	DIMENSIONS	
	MIN.	MAX.
A	1.90	2.20
B	3.30	3.94
C	4.05	4.75
D	2.13	2.65
E	5.08	5.59
F	0.76	1.52
G	0.203 TYP.	
H	0.15	0.31

**SMB Suggested Pad Layout**

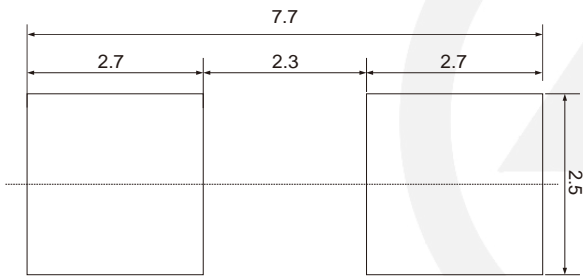

**Note:**

1. Controlling dimension: in millimeters.
2. General tolerance:  $\pm 0.05\text{mm}$
3. The pad layout is for reference purpose only.

**Carrier Tape Dimensions**

Unit : mm

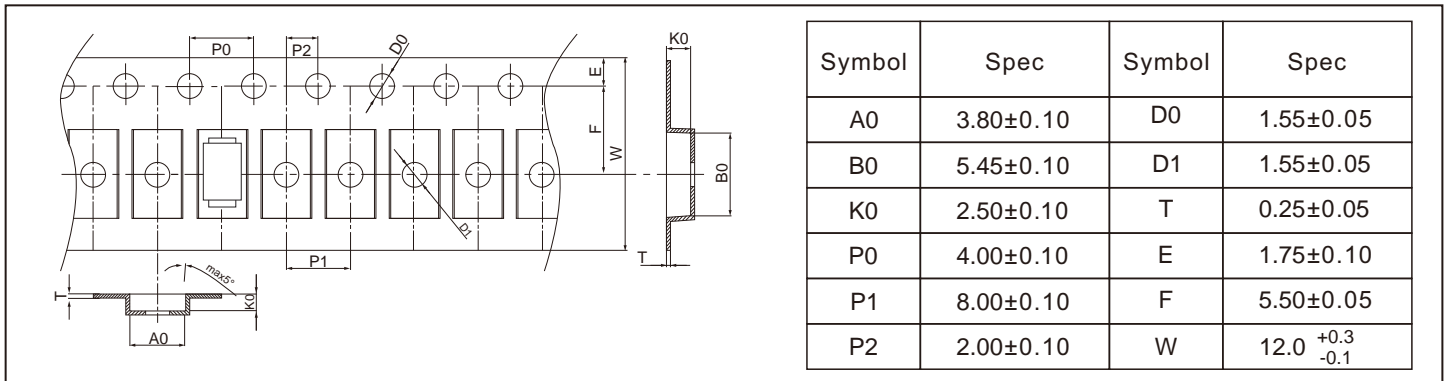

**Reel Dimensions**

Unit : mm

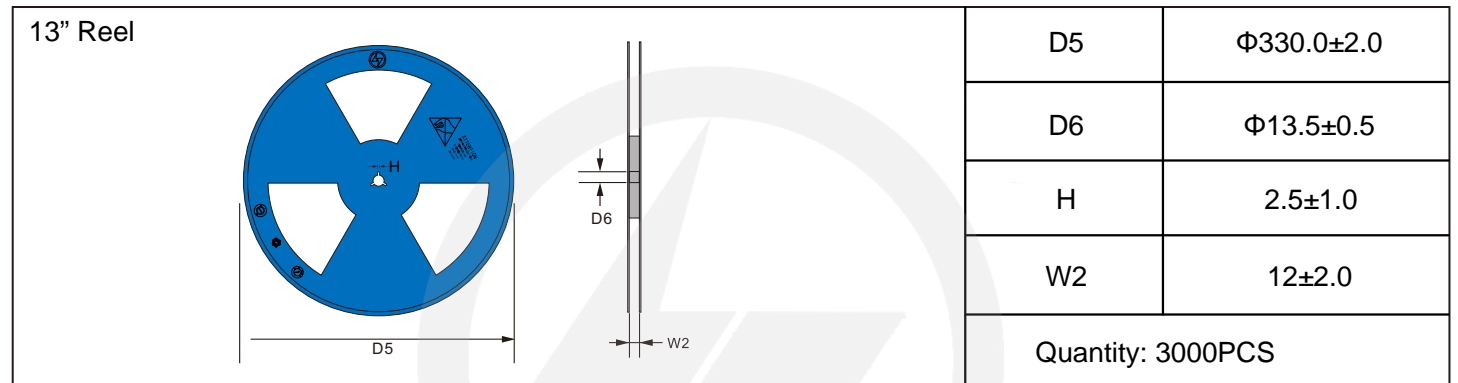

**Packaging**

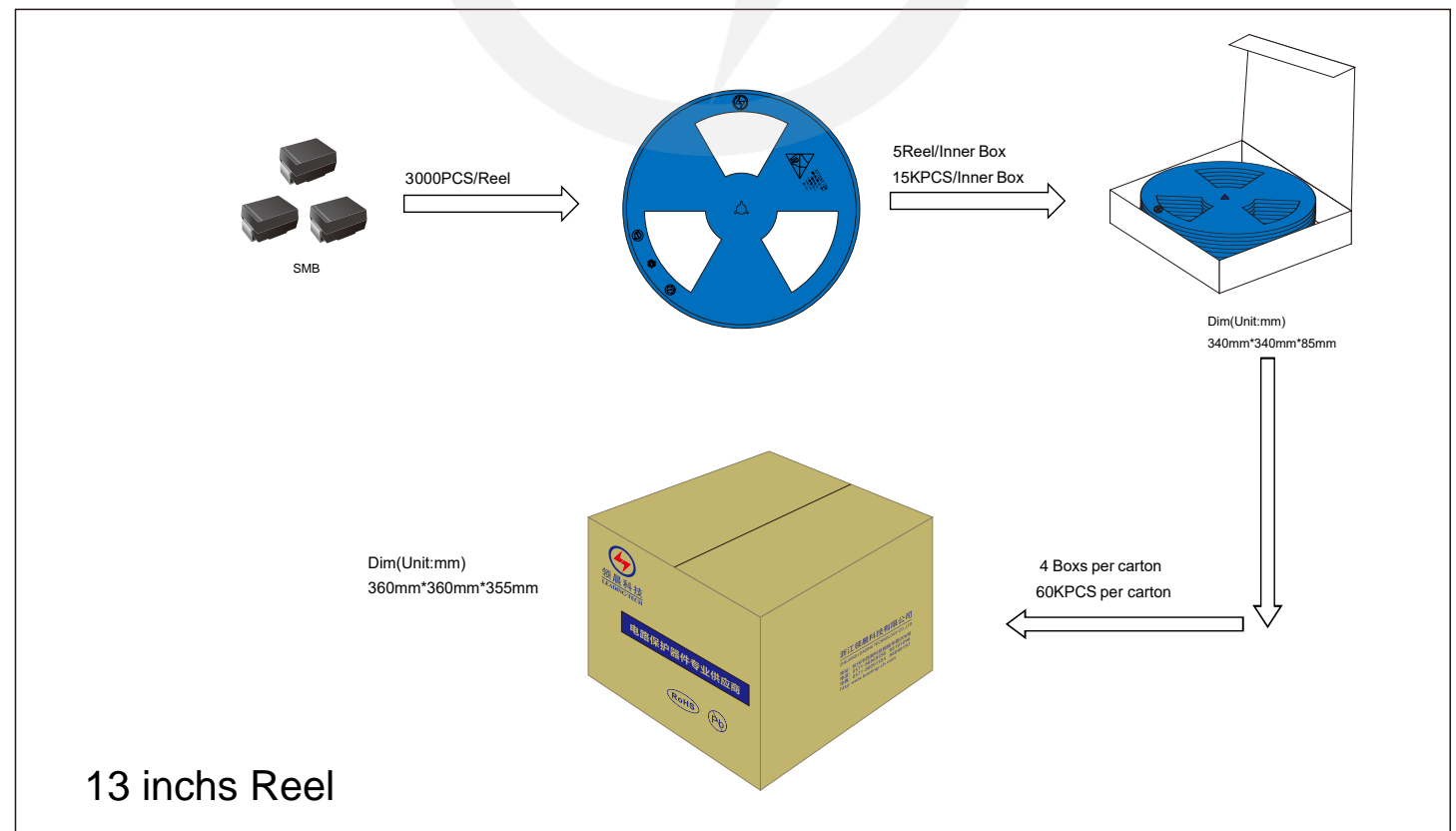



Recommended Soldering Conditions

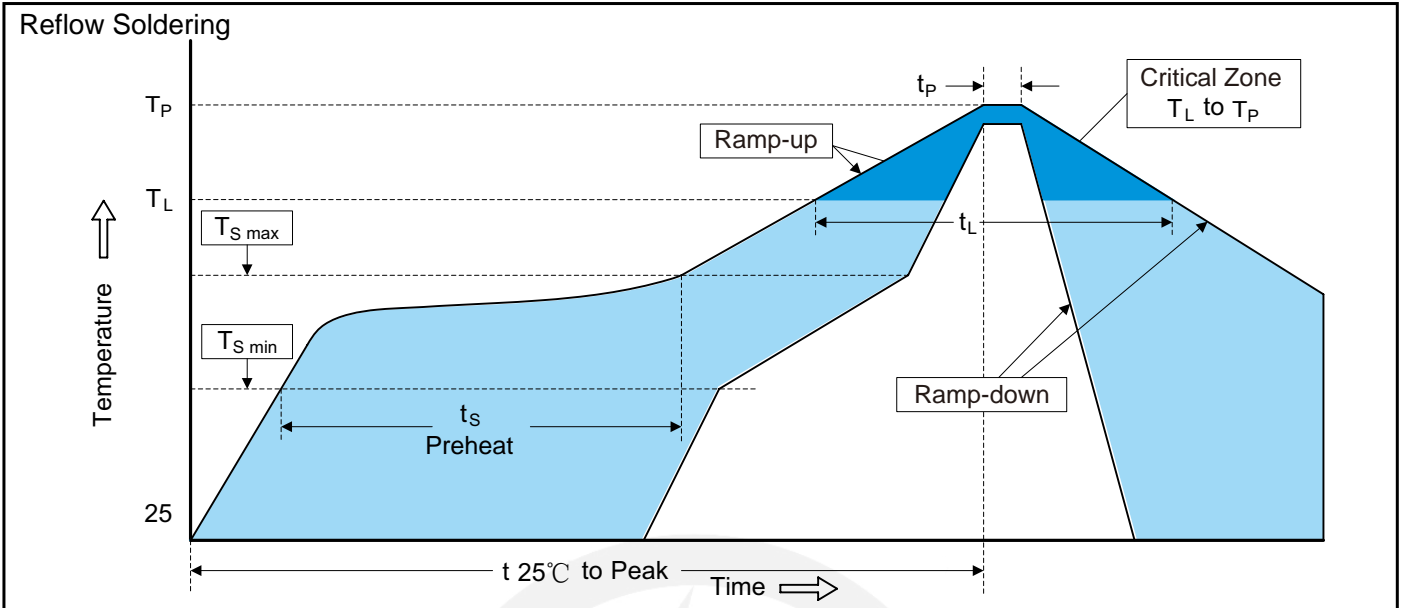

Recommended Conditions

Profile Feature	Pb-Free Assembly
Average ramp-up rate (T <sub>L</sub> to T <sub>P</sub> )	3°C/second max.
Preheat	
-Temperature Min (T <sub>S min</sub> )	150°C
-Temperature Max (T <sub>S max</sub> )	200°C
-Time (min to max) (t <sub>s</sub> )	60-180 seconds
T <sub>S max</sub> to T <sub>L</sub>	
-Ramp-up Rate	3°C/second max.
Time maintained above:	
-Temperature (T <sub>L</sub> )	217°C
-Time (t <sub>L</sub> )	60-150 seconds
Peak Temperature (T <sub>P</sub> )	260°C
Time within 5°C of actual Peak Temperature (t <sub>p</sub> )	20-40 seconds
Ramp-down Rate	6°C/second max.
Time 25°C to Peak Temperature	8 minutes max.

## Important Notice and Disclaimer

Leading-Tech reserves the right to make changes to this document and its products and specifications at any time without notice.

Customers should obtain and confirm the latest product information and specifications before final design, purchase or use.

Leading-Tech makes no warranty, representation or guarantee regarding the suitability of its products for any particular purpose, not does Leading-Tech assume any liability for application assistance or customer product design.

Leading-Tech does not warrant or accept any liability with products which are purchase or used for any unintended or unauthorized application.

No license is granted by implication or otherwise under any intellectual property rights of Leading-Tech.

Leading-Tech products are not authorized for use as critical components in life support devices or systems without express written approval of Leading-tech.

## Version Update Information

Series NO.	Enactment/Revision Date	Effective Date	Version	Revision content	Revision Reason	Revision Person	Note
01	2024.10.17	2024.10.17	3.0	New File	/	Ding	
02	2025.04.18	2025.04.18	3.1	Increase capacitance value	/	Ding	
03	2025.10.29	2025.10.29	3.2	Modify Marking	/	Ding	