

Transistor(PNP)

Features

- Collector current $I_C = -1.5A$
- Power amplifier applications
- Lead free in comply with EU RoHS 2011/65/EU directives

Mechanical Data

- Case: SOT-23
- Approx. Weight: 8.1mg

Ordering Information

Part Number	Shipping	Reel
LTSS8550HP/Q-TR3	3000PCS Tape&Reel	7 inches
LTSS8550HP/Q-TR12	12000PCS Tape&Reel	13 inches

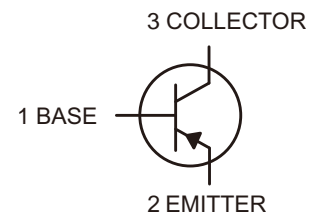
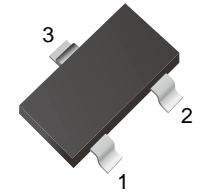

Absolute Maximum Ratings ($T_a = 25^\circ C$)

Symbol	Parameter	Value	Unit
V_{CBO}	Collector-Base Voltage	-50	V
V_{CEO}	Collector-Emitter Voltage	-50	V
V_{EBO}	Emitter-Base Voltage	-6	V
I_C	Collector Current	-1.5	A
P_C	Collector Power Dissipation	300	mW
$R_{\theta JA}$	Thermal Resistance From Junction To Ambient	400	$^\circ C/W$
T_J, T_{stg}	Operation Junction And Storage Temperature Range	-55 to +150	$^\circ C$

Electrical Characteristics ($T_a = 25^\circ C$ unless otherwise specified)

Symbol	Parameter	Test conditions	Min	Typ	Max	Unit
$V_{(BR)CBO}$	Collector-base breakdown voltage	$I_C = -100\mu A, I_E = 0$	-50			V
$V_{(BR)CEO}$	Collector-emitter breakdown voltage	$I_C = -2mA, I_B = 0$	-50			V
$V_{(BR)EBO}$	Emitter-base breakdown voltage	$I_E = -100\mu A, I_C = 0$	-6			V
V_{BE}	Base-Emitter Voltage	$V_{CE} = -1V, I_C = -10mA$		-0.66	-1	V
I_{CBO}	Collector cut-off current	$V_{CB} = -40V, I_E = 0$			-100	nA
I_{EBO}	Emitter cut-off current	$V_{EB} = -5V, I_C = 0$			-100	nA
$h_{FE(1)}$	DC current gain(1)	$V_{CE} = -1V, I_C = -100mA$	100		320	
$h_{FE(2)}$	DC current gain(2)	$V_{CE} = -1V, I_C = -800mA$	40			
$V_{CE(sat)}$	Collector-emitter saturation voltage	$I_C = -800mA, I_B = -80mA$			-0.5	V
$V_{BE(sat)}$	Base-emitter saturation voltage				-1.2	V

$h_{FE(1)}$ Classifications & Marking

Rank	LTSS8550HP	LTSS8550HQ
$h_{FE(1)}$	100~200	160~320
Marking	KIO	KIY



Characteristics Curves

Fig.1 HFE-Ic Vce=1V

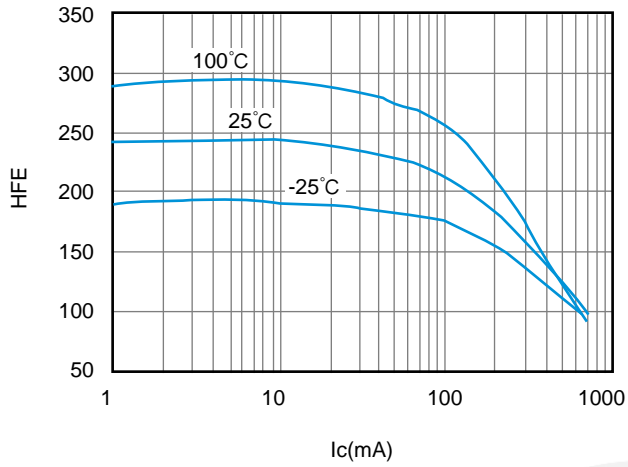

Fig.2 Vcesat-Ic Ic/Ib=10

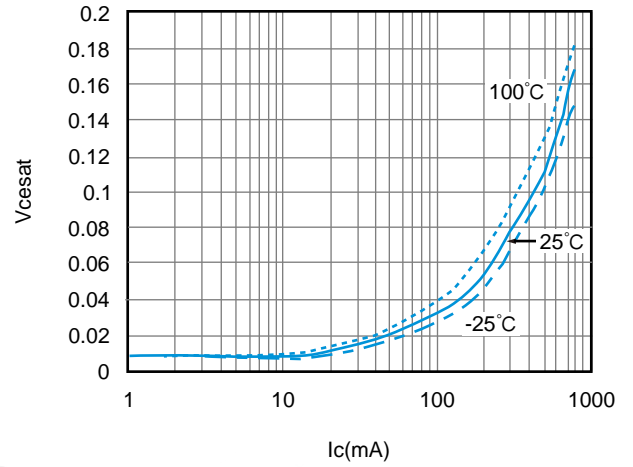

Fig.3 Ic-Vbe

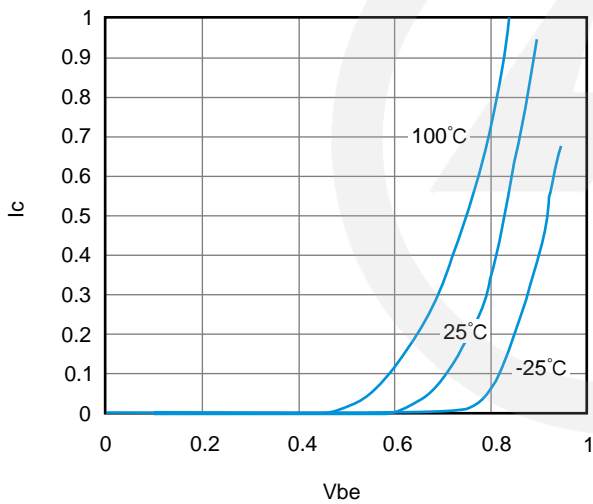
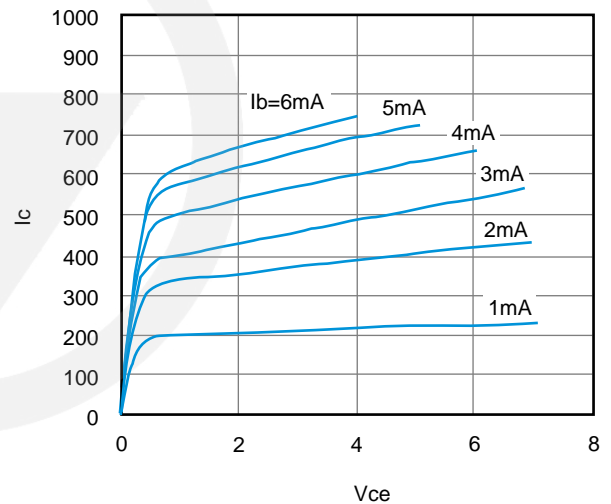

Fig.4 Ic-Vce





SOT-23 Package Outline

Unit: mm

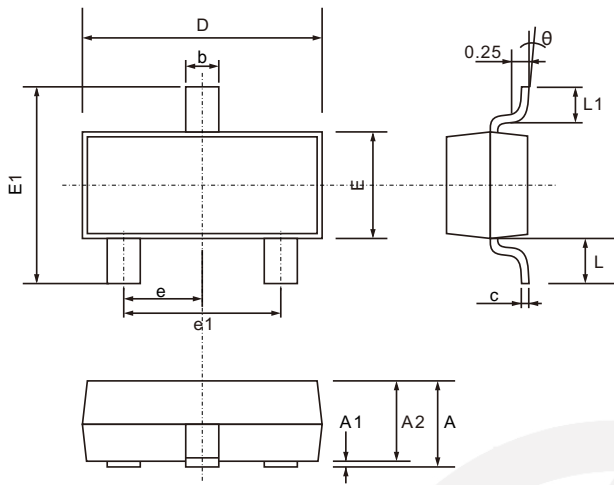

SYMBOL	DIMENSIONS	
	MIN.	MAX.
A	0.900	1.200
A1	0.000	0.100
A2	0.900	1.050
b	0.300	0.500
c	0.080	0.200
D	2.700	3.100
E	1.200	1.400
E1	2.200	2.600
e	0.950 TYP.	
e1	1.750	2.050
L	0.550 TYP.	
L1	0.300	0.500
θ	0°	8°

SOT-23 Suggested Pad Layout

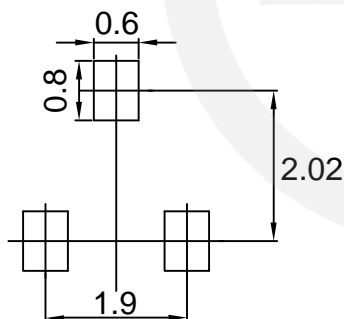

- Note:
1. Controlling dimension: in millimeters.
 2. General tolerance: ± 0.05 mm
 3. The pad layout is for reference purpose only.

Carrier Tape Dimensions

Unit : mm

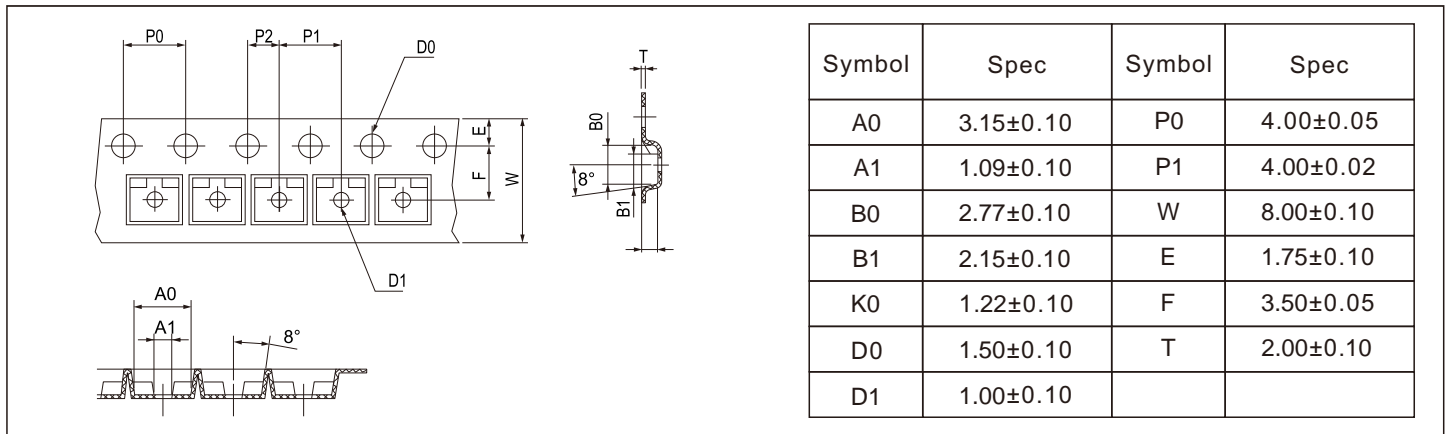

Reel Dimensions

Unit : mm

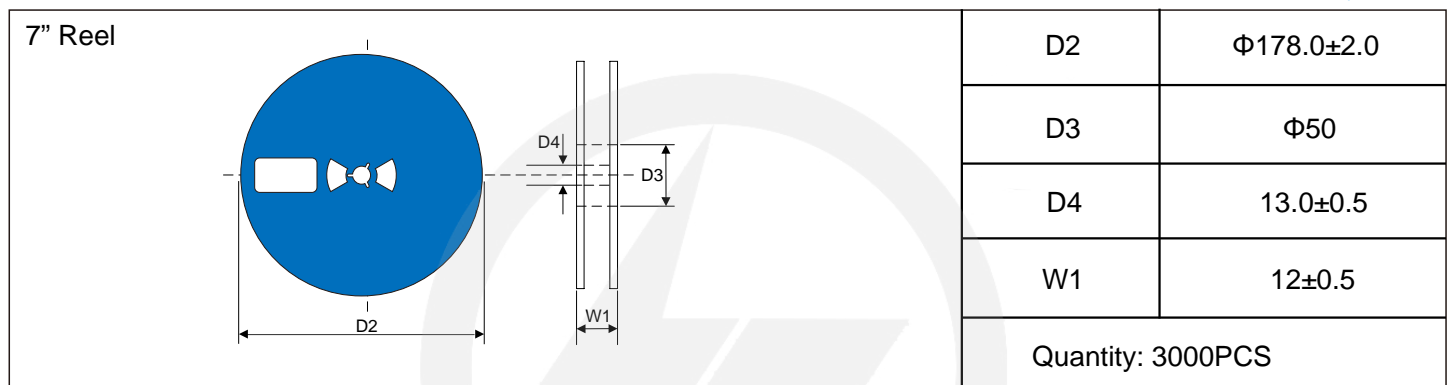

Reel Dimensions

Unit : mm

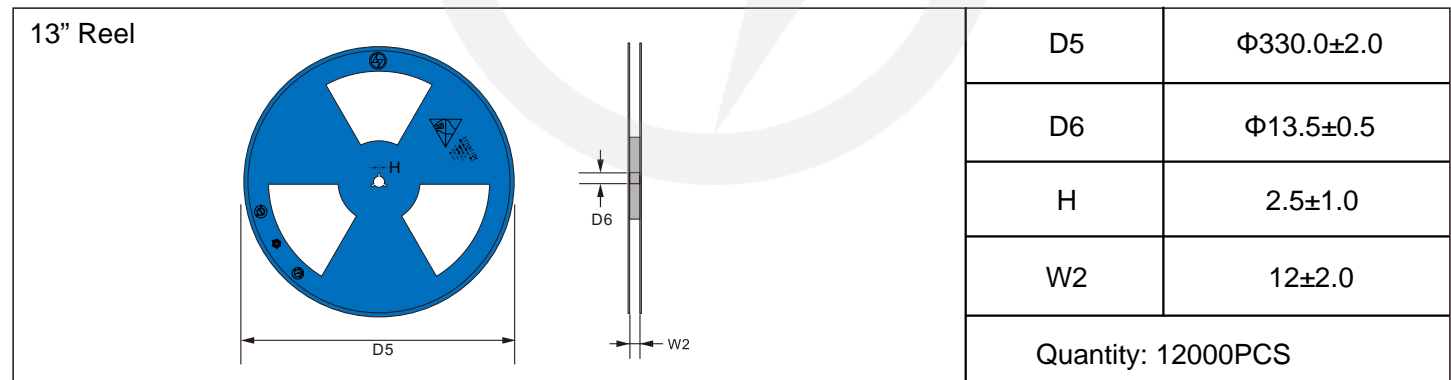

Packaging

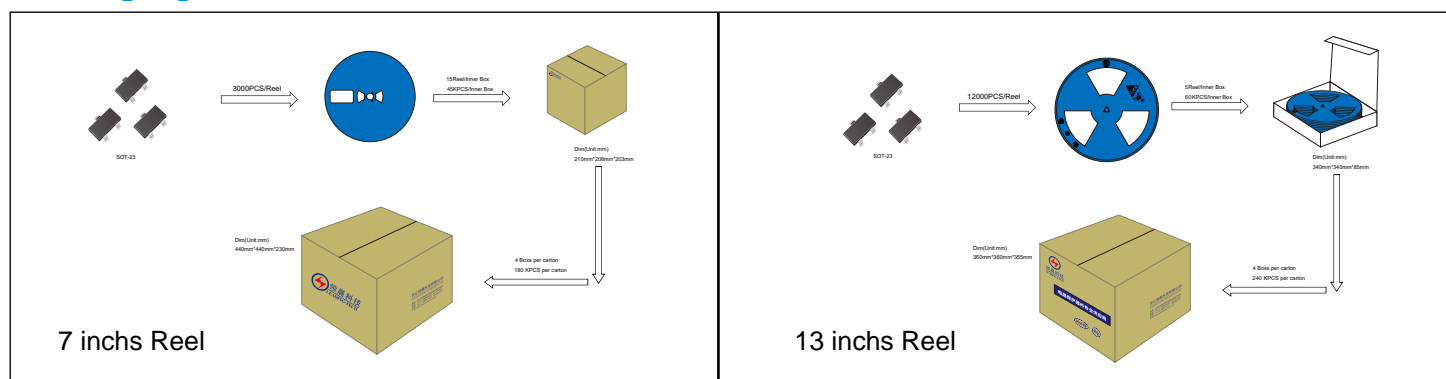



Recommended Soldering Conditions



Recommended Conditions

Profile Feature	Pb-Free Assembly
Average ramp-up rate (T _L to T _P)	3°C/second max.
Preheat	
-Temperature Min (T _{S min})	150°C
-Temperature Max (T _{S max})	200°C
-Time (min to max) (t _s)	60-180 seconds
T _{S max} to T _L	
-Ramp-up Rate	3°C/second max.
Time maintained above:	
-Temperature (T _L)	217°C
-Time (t _L)	60-150 seconds
Peak Temperature (T _P)	260°C
Time within 5°C of actual Peak Temperature (t _p)	20-40 seconds
Ramp-down Rate	6°C/second max.
Time 25°C to Peak Temperature	8 minutes max.

Important Notice and Disclaimer

Leading-Tech reserves the right to make changes to this document and its products and specifications at any time without notice.

Customers should obtain and confirm the latest product information and specifications before final design, purchase or use.

Leading-Tech makes no warranty, representation or guarantee regarding the suitability of its products for any particular purpose, not does Leading-Tech assume any liability for application assistance or customer product design.

Leading-Tech does not warrant or accept any liability with products which are purchase or used for any unintended or unauthorized application.

No license is granted by implication or otherwise under any intellectual property rights of Leading-Tech.

Leading-Tech products are not authorized for use as critical components in life support devices or systems without express written approval of Leading-Tech.

Version Update Information

Series NO.	Enactment/Revision Date	Effective Date	Version	Revision Content	Revision Reason	Revision Person	Note
01	2025.07.06	2025.07.06	3.0	New file	/	Ding	
02	2026.03.06	2026.03.06	3.1	Package outline E1(max)=2.6mm	/	Ding	