

Transistor(NPN)

Features

- Lead free in comply with EU RoHS 2011/65/EU directives

Ordering Information

Part Number	Marking	Shipping	Reel
LTSS8050x-TR3	Y1	3000PCS Tape&Reel	7 inchs
LTSS8050x-TR12	Y1	12000PCS Tape&Reel	13 inchs

* "x" means h_{FE} Rank

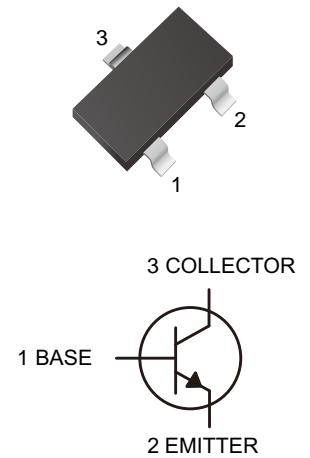

Maximum Ratings (Ta=25 unless otherwise noted)

Symbol	Parameter	Value	Unit
V _{CBO}	Collector-Base Voltage	40	V
V _{CEO}	Collector-Emitter Voltage	25	V
V _{EBO}	Emitter-Base Voltage	5	V
I _C	Collector Current	1.5	A
P _C	Collector Power Dissipation	300	mW
R _{θJA}	Thermal Resistance From Junction To Ambient	417	°C/W
T _J , T _{stg}	Operation Junction and Storage Temperature Range	-55~+150	°C

Electrical characteristics (Ta=25 unless otherwise specified)

Parameter	Symbol	Test conditions	Min	Typ	Max	Unit
Collector-base breakdown voltage	V _{(BR)CBO}	I _C = 100μA, I _E =0	40			V
Collector-emitter breakdown voltage	V _{(BR)CEO}	I _C = 0.1mA, I _B =0	25			V
Emitter-base breakdown voltage	V _{(BR)EBO}	I _E =100μA, I _C =0	5			V
Collector cut-off current	I _{CBO}	V _{CB} =40V, I _E =0			0.1	μA
Collector cut-off current	I _{CEO}	V _{CE} =20V, I _E =0			0.1	μA
Emitter cut-off current	I _{EBO}	V _{EB} = 5V, I _C =0			0.1	μA
DC current gain	h _{FE(1)}	V _{CE} =1V, I _C = 100mA	120		400	
	h _{FE(2)}	V _{CE} =1V, I _C = 800mA	40			
Collector-emitter saturation voltage	V _{CE(sat)}	I _C =800mA, I _B = 80mA			0.5	V
Base-emitter saturation voltage	V _{BE(sat)}	I _C =800mA, I _B = 80mA			1.2	V
Transition frequency	f _T	V _{CE} =10V, I _C = 50mA f=30MHz	100			MHz

Classification Of h_{FE}

RANK	LTSS8050L	LTSS8050H	LTSS8050J
RANGE	120-200	200-350	300-400



Characteristics Curves

Fig.1 Static Characteristic

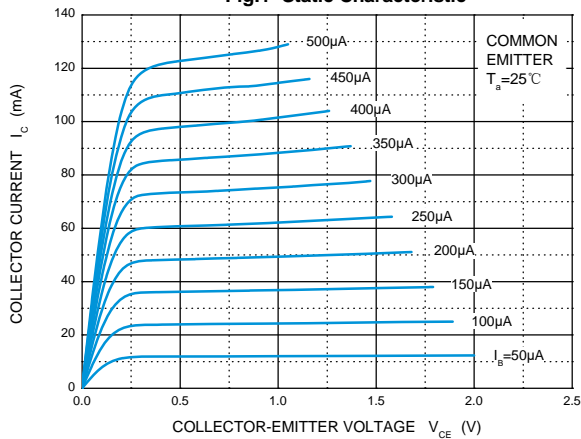

Fig.2 h_{FE} vs I_C

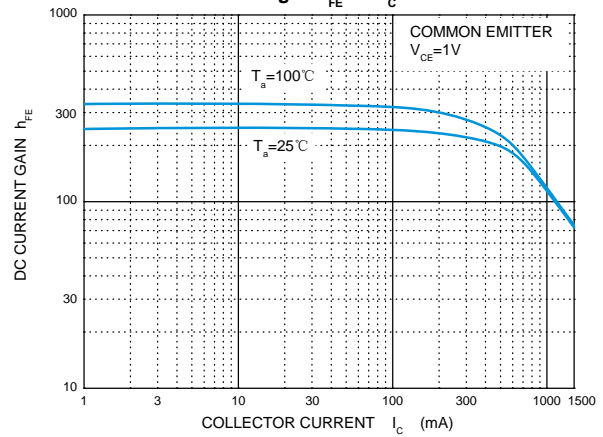

Fig.3 V_{CEsat} vs I_C

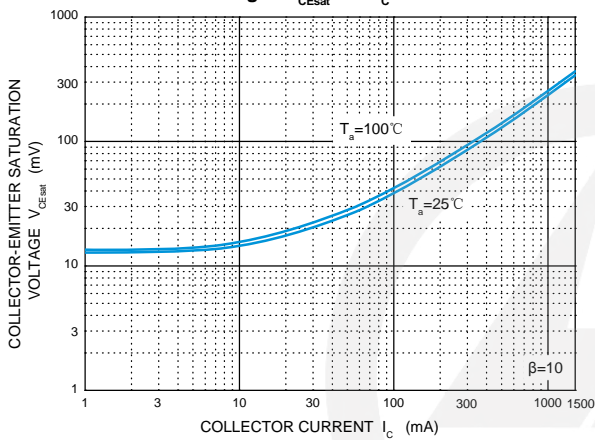

Fig.4 V_{BEsat} vs I_C

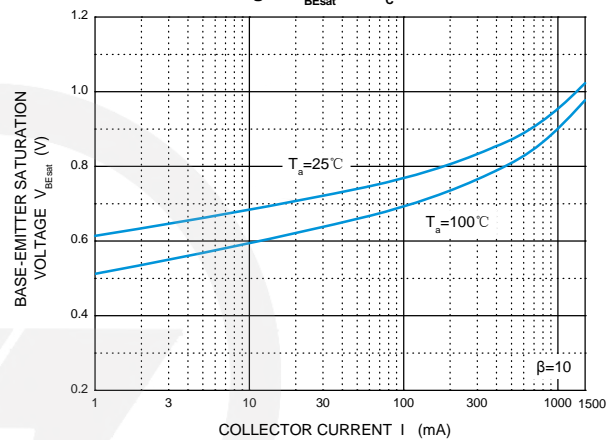

Fig.5 V_{BE} vs I_C

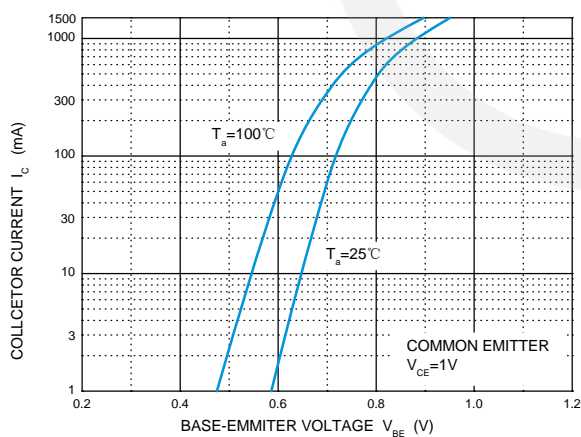

Fig.6 C_{ob}/C_{ib} vs V_{CB}/V_{EB}

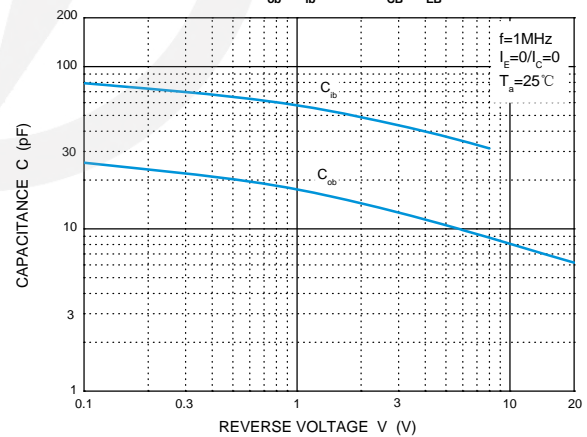

Fig.7 f_T vs I_C

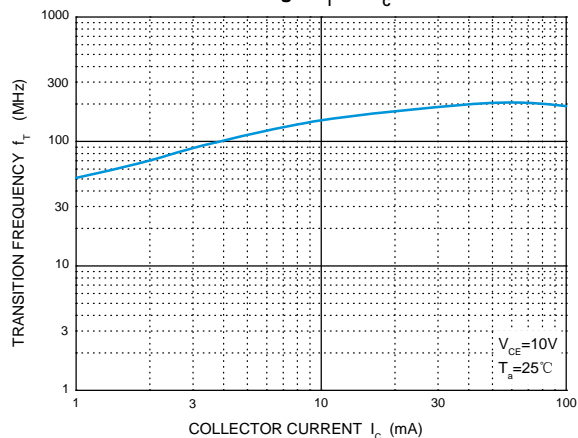
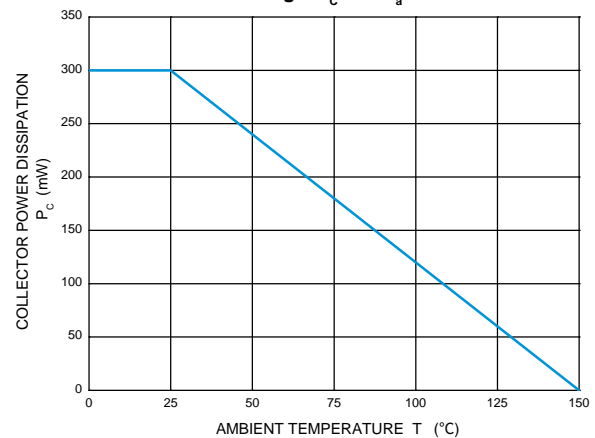

Fig.8 P_C vs T_a





SOT-23 Package Outline

Unit: mm

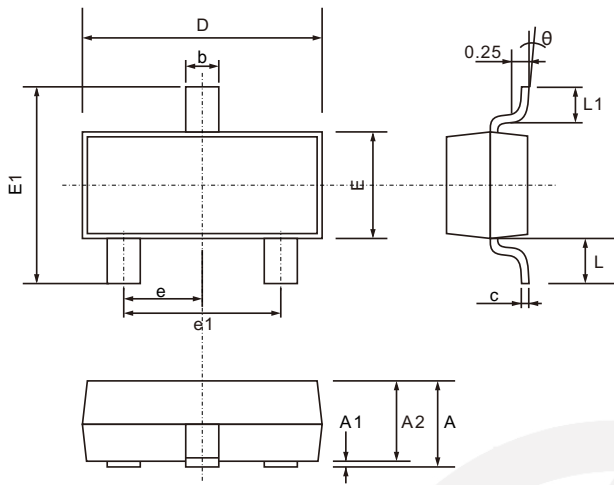

SYMBOL	DIMENSIONS	
	MIN.	MAX.
A	0.900	1.200
A1	0.000	0.100
A2	0.900	1.050
b	0.300	0.500
c	0.080	0.200
D	2.700	3.100
E	1.200	1.400
E1	2.200	2.600
e	0.950 TYP.	
e1	1.750	2.050
L	0.550 TYP.	
L1	0.300	0.500
θ	0°	8°

SOT-23 Suggested Pad Layout

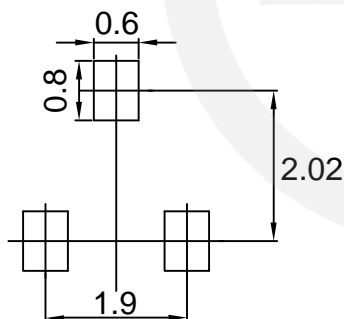

- Note:
1. Controlling dimension: in millimeters.
 2. General tolerance: $\pm 0.05\text{mm}$
 3. The pad layout is for reference purpose only.

Carrier Tape Dimensions

Unit : mm

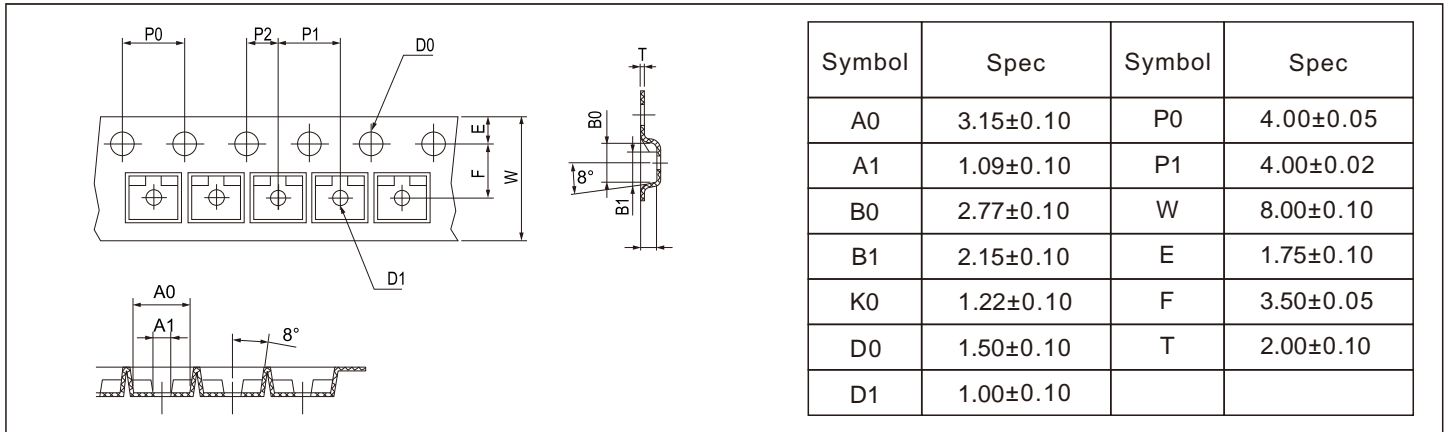

Reel Dimensions

Unit : mm

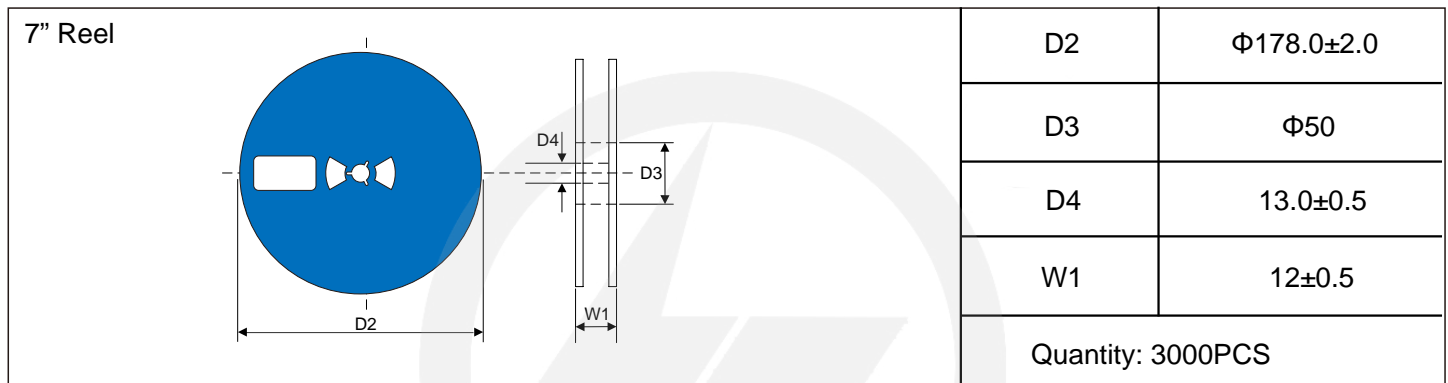

Reel Dimensions

Unit : mm

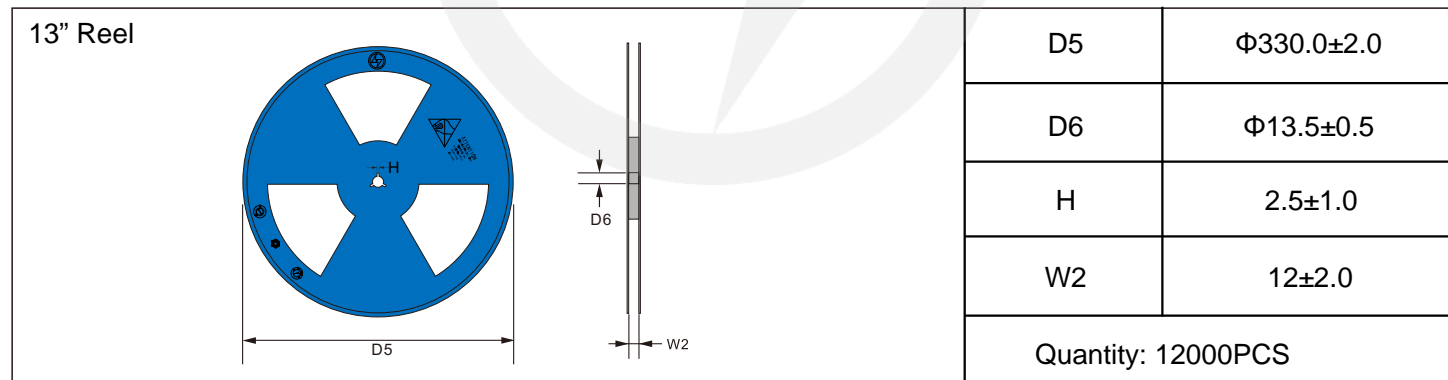

Packaging

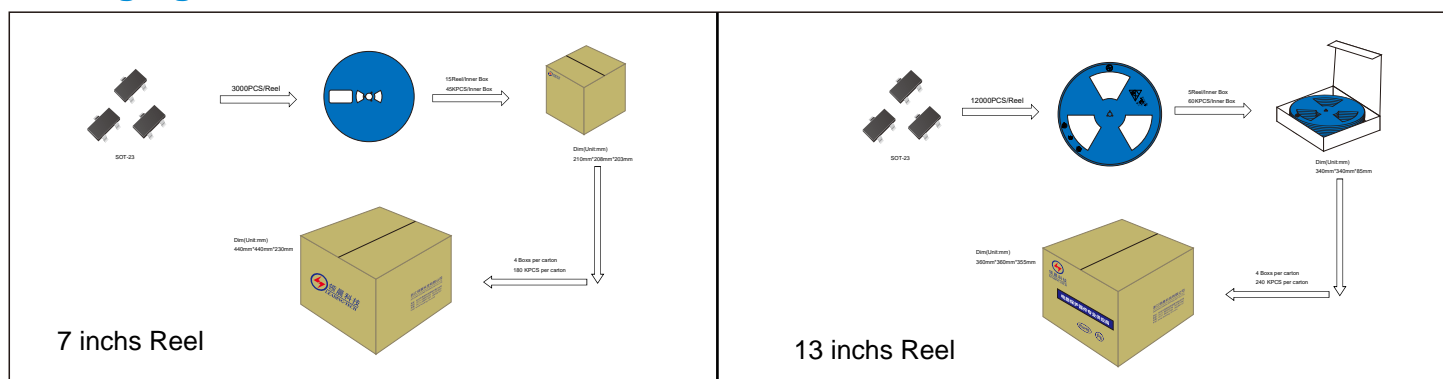



Recommended Soldering Conditions



Recommended Conditions

Profile Feature	Pb-Free Assembly
Average ramp-up rate (T_L to T_P)	3°C/second max.
Preheat	
-Temperature Min ($T_{S\ min}$)	150°C
-Temperature Max ($T_{S\ max}$)	200°C
-Time (min to max) (t_s)	60-180 seconds
$T_{S\ max}$ to T_L	
-Ramp-up Rate	3°C/second max.
Time maintained above:	
-Temperature (T_L)	217°C
-Time (t_L)	60-150 seconds
Peak Temperature (T_P)	260°C
Time within 5°C of actual Peak Temperature (t_p)	20-40 seconds
Ramp-down Rate	6°C/second max.
Time 25°C to Peak Temperature	8 minutes max.

Important Notice and Disclaimer

Leading-Tech reserves the right to make changes to this document and its products and specifications at any time without notice.

Customers should obtain and confirm the latest product information and specifications before final design, purchase or use.

Leading-Tech makes no warranty, representation or guarantee regarding the suitability of its products for any particular purpose, not does Leading-Tech assume any liability for application assistance or customer product design.

Leading-Tech does not warrant or accept any liability with products which are purchase or used for any unintended or unauthorized application.

No license is granted by implication or otherwise under any intellectual property rights of Leading-Tech.

Leading-Tech products are not authorized for use as critical components in life support devices or systems without express written approval of Leading-Tech.

Version Update Information

Series NO.	Enactment/Revision Date	Effective Date	Version	Revision Content	Revision Reason	Revision Person	Note
01	2024.09.07	2024.09.07	3.0	New file	/	Ding	
02	2025.04.28	2025.04.28	3.1	Model differentiation	/	Ding	
03	2026.03.06	2026.03.06	3.2	Package outline E1(max)=2.6mm	/	Ding	