

Transistor(NPN)

Features

- Collector Current: $I_C=0.5A$
- Approx. Weight: 9.2mg / 0.00032452oz
- Lead free in comply with EU RoHS 2011/65/EU directives

Ordering Information

Part Number	Marking	Shipping	Reel
LTS8050-TR3	J3Y	3000PCS Tape&Reel	7 inches
LTS8050-TR12	J3Y	12000PCS Tape&Reel	13 inches

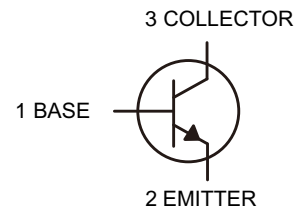
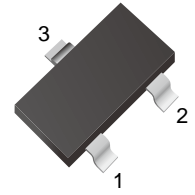

Limiting Values (Absolute Maximum Ratings)

Symbol	Parameter	Value	Unit
V_{CBO}	Collector-Base Voltage	40	V
V_{CEO}	Collector-Emitter Voltage	25	V
V_{EBO}	Emitter-Base Voltage	5	V
I_C	Collector Current	500	mA
P_C	Collector Power Dissipation	300	mW
$R_{\theta JA}$	Thermal Resistance From Junction To Ambient	417	$^{\circ}C/W$
T_J	Junction Temperature	150	$^{\circ}C$
T_{STG}	Storage Temperature	-55~+150	$^{\circ}C$

Electrical characteristics ($T_a=25^{\circ}C$ unless otherwise specified)

Parameter	Symbol	Test condition	Min	Max	Unit
Collector-base breakdown voltage	$V_{(BR)CBO}$	$I_C=100\mu A, I_E=0$	40		V
Collector-emitter breakdown voltage	$V_{(BR)CEO}$	$I_C=1mA, I_B=0$	25		V
Emitter-base breakdown voltage	$V_{(BR)EBO}$	$I_E=100\mu A, I_C=0$	5		V
Collector cut-off current	I_{CBO}	$V_{CB}=40V, I_E=0$		0.1	μA
Collector cut-off current	I_{CEO}	$V_{CE}=20V, I_B=0$		0.1	μA
Emitter cut-off current	I_{EBO}	$V_{EB}=5V, I_C=0$		0.1	μA
DC current gain	$h_{FE(1)}$	$V_{CE}=1V, I_C=50mA$	120	400	
	$h_{FE(2)}$	$V_{CE}=1V, I_C=500mA$	50		
Collector-emitter saturation voltage	$V_{CE(sat)}$	$I_C=500mA, I_B=50mA$		0.6	V
Base-emitter saturation voltage	$V_{BE(sat)}$	$I_C=500mA, I_B=50mA$		1.2	V
Transition frequency	f_T	$V_{CE}=6V, I_C=20mA$ $f=30MHz$	150		MHz

Classification Of h_{FE}

RANGE	120-200	200-350	300-400
RANK	L	H	J



Characteristics Curves

Fig.1 Static Characteristic

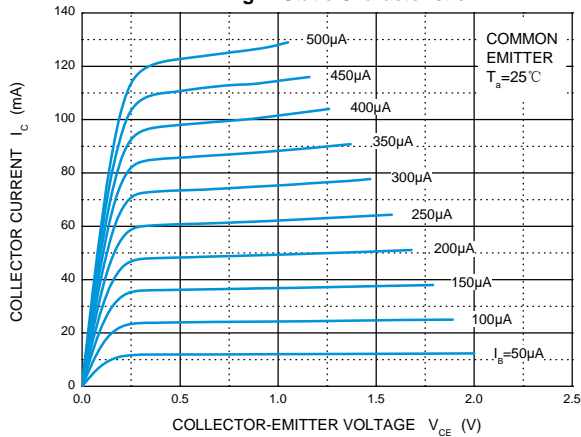

Fig.2 h_{FE} vs I_c

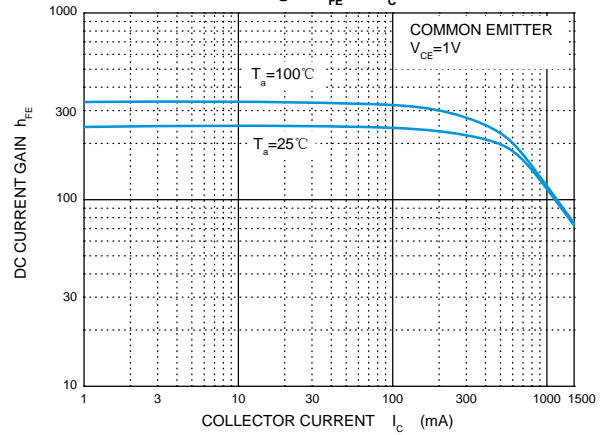

Fig.3 V_{CEsat} vs I_c

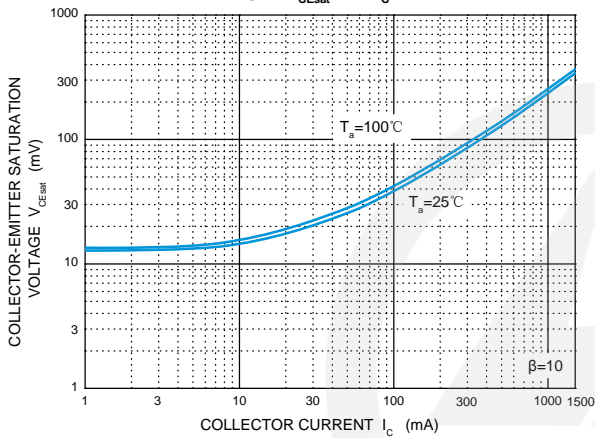

Fig.4 V_{BEsat} vs I_c

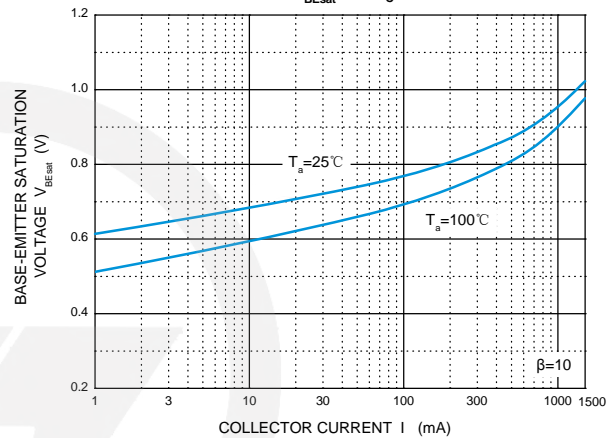

Fig.5 V_{BE} vs I_c

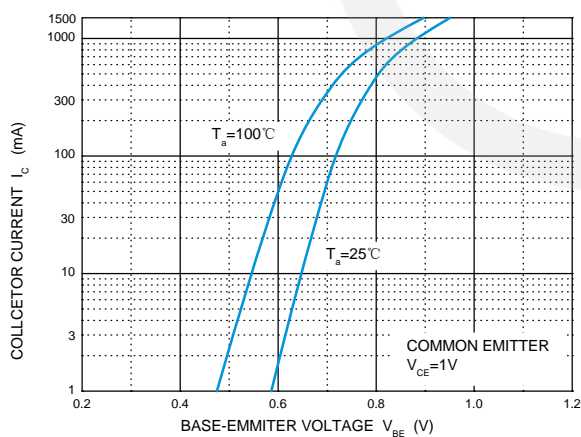

Fig.6 C_{ob}/C_{ib} vs V_{CB}/V_{EB}

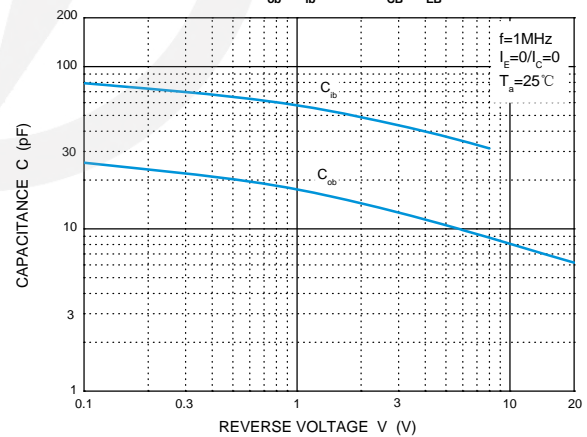

Fig.7 f_T vs I_c

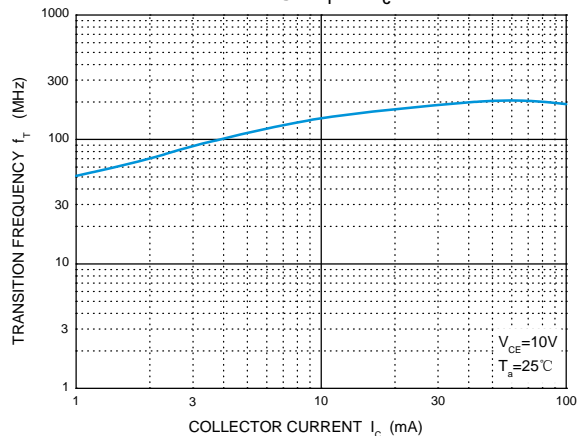
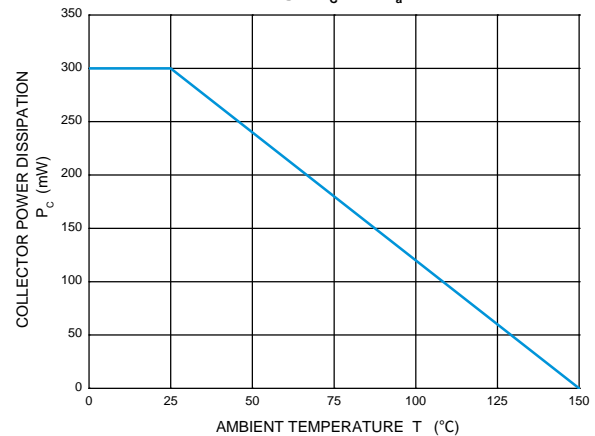

Fig.8 P_c vs T_a





SOT-23 Package Outline

Unit: mm

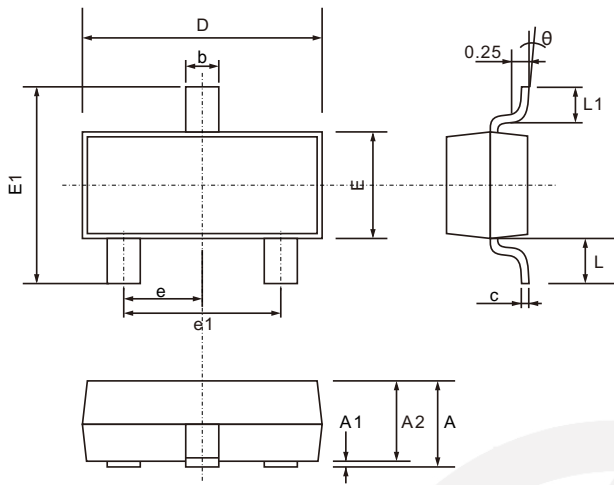

SYMBOL	DIMENSIONS	
	MIN.	MAX.
A	0.900	1.200
A1	0.000	0.100
A2	0.900	1.050
b	0.300	0.500
c	0.080	0.200
D	2.700	3.100
E	1.200	1.400
E1	2.200	2.600
e	0.950 TYP.	
e1	1.750	2.050
L	0.550 TYP.	
L1	0.300	0.500
θ	0°	8°

SOT-23 Suggested Pad Layout

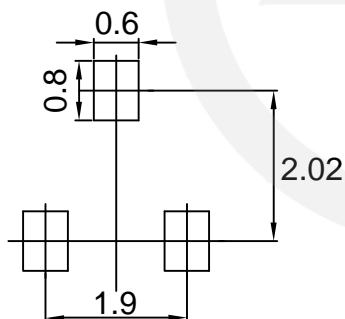

- Note:
1. Controlling dimension: in millimeters.
 2. General tolerance: $\pm 0.05\text{mm}$
 3. The pad layout is for reference purpose only.

Carrier Tape Dimensions

Unit : mm

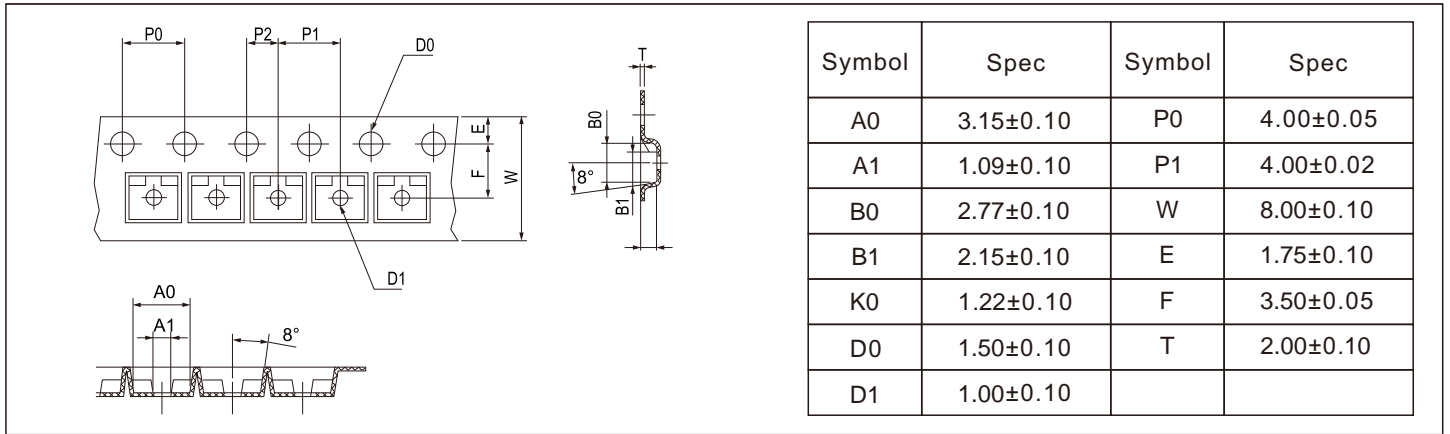

Reel Dimensions

Unit : mm

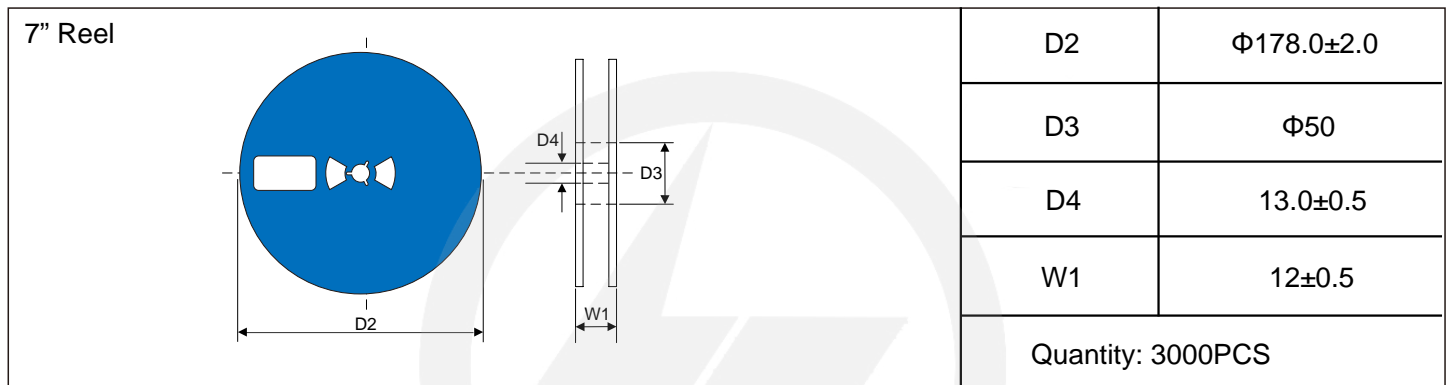

Reel Dimensions

Unit : mm

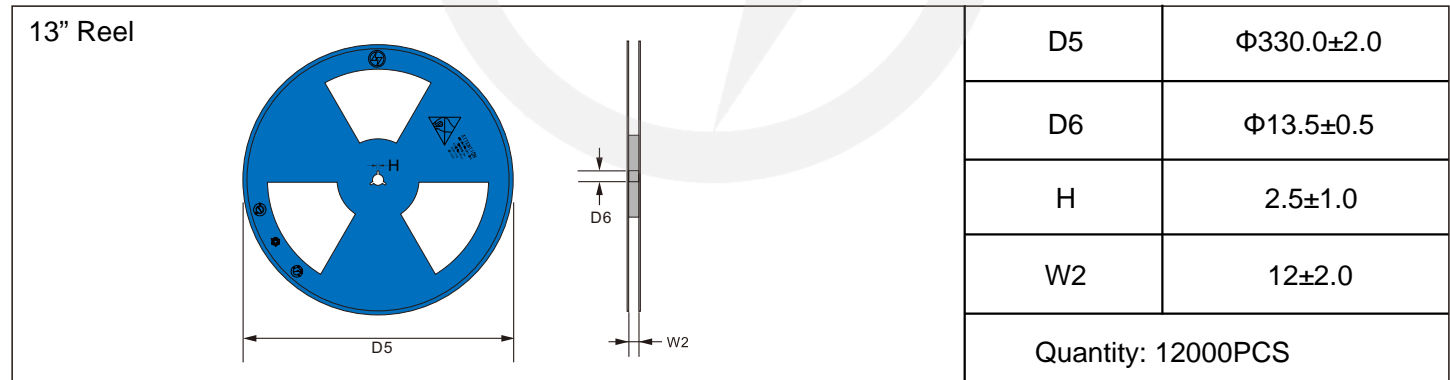

Packaging

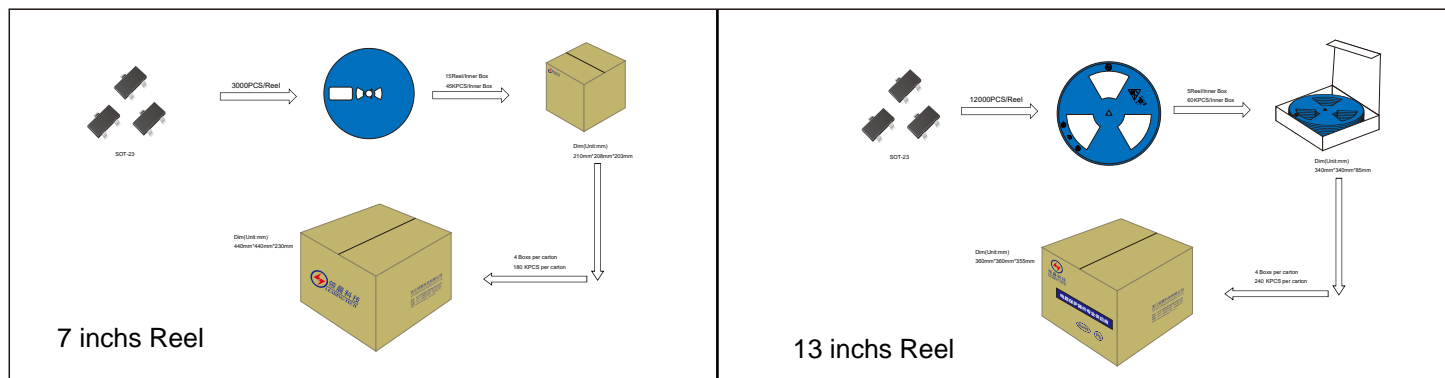



Recommended Soldering Conditions



Recommended Conditions

Profile Feature	Pb-Free Assembly
Average ramp-up rate (T_L to T_P)	3°C/second max.
Preheat	
-Temperature Min ($T_{S\ min}$)	150°C
-Temperature Max ($T_{S\ max}$)	200°C
-Time (min to max) (t_s)	60-180 seconds
$T_{S\ max}$ to T_L	
-Ramp-up Rate	3°C/second max.
Time maintained above:	
-Temperature (T_L)	217°C
-Time (t_L)	60-150 seconds
Peak Temperature (T_P)	260°C
Time within 5°C of actual Peak Temperature (t_p)	20-40 seconds
Ramp-down Rate	6°C/second max.
Time 25°C to Peak Temperature	8 minutes max.

Important Notice and Disclaimer

Leading-Tech reserves the right to make changes to this document and its products and specifications at any time without notice.

Customers should obtain and confirm the latest product information and specifications before final design, purchase or use.

Leading-Tech makes no warranty, representation or guarantee regarding the suitability of its products for any particular purpose, not does Leading-Tech assume any liability for application assistance or customer product design.

Leading-Tech does not warrant or accept any liability with products which are purchase or used for any unintended or unauthorized application.

No license is granted by implication or otherwise under any intellectual property rights of Leading-Tech.

Leading-Tech products are not authorized for use as critical components in life support devices or systems without express written approval of Leading-Tech.

Version Update Information

Series NO.	Enactment/Revision Date	Effective Date	Version	Revision Content	Revision Reason	Revision Person	Note
01	2024.03.12	2024.03.12	3.0	New file	/	Ding	
02	2025.04.15	2025.04.15	3.1	Add weight (Weight: 9.2mg)	/	Ding	
03	2026.03.06	2026.03.06	3.2	Package outline E1(max)=2.6mm	/	Ding	