

Switching Diodes

Features

- Fast Switching Speed
- For General Purpose Switching Applications
- High Conductance
- Lead free in comply with EU RoHS 2011/65/EU directives

Mechanical Data

- Case: SOT-23
- Approx. Weight: 8.1mg

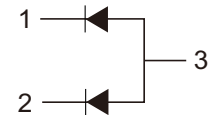
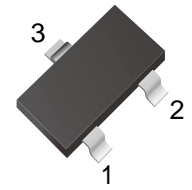

Ordering Information

Part Number	Marking	Shipping	Reel
LTS56A1-TR3	A1	3000PCS Tape&Reel	7 inchs
LTS56A1-TR12	A1	12000PCS Tape&Reel	13 inchs

Limiting Values (Absolute Maximum Ratings)

Parameter	Symbol	Limit	Unit
Reverse Voltage	V_R	70	V
Forward Current	I_F	215	mA
Non-Repetitive Peak Forward Surge Current @ $t=1\text{ms}$	I_{FSM}	1	A
Power Dissipation	P_D	225	mW
Thermal Resistance Junction to Ambient	$R_{\theta JA}$	556	$^{\circ}\text{C}/\text{W}$
Junction Temperature	T_J	150	$^{\circ}\text{C}$
Storage Temperature range	T_{STG}	-55~+150	$^{\circ}\text{C}$

Electrical Characteristics (Ta =25 $^{\circ}\text{C}$ Unless otherwise specified)

Parameter	Symbol	Min	Typ	Max	Unit	Conditions
Reverse breakdown voltage	V_R	70			V	$I_R=100\mu\text{A}$
Forward voltage	V_{F1}			0.715	V	$I_F=1\text{mA}$
	V_{F2}			0.855	V	$I_F=10\text{mA}$
	V_{F3}			1	V	$I_F=50\text{mA}$
	V_{F4}			1.25	V	$I_F=150\text{mA}$
Reverse current	I_R			2.5	μA	$V_R=70\text{V}$
Capacitance between terminals	C_T			1.5	pF	$V_R=0, f=1\text{MHz}$
Reverse recovery time	t_{rr}			6	ns	$I_F = I_R = 10\text{mA}$, $I_{rr} = 0.1 \times I_R$, $R_L = 100\Omega$



Characteristics Curves

Fig.1 Forward Characteristics

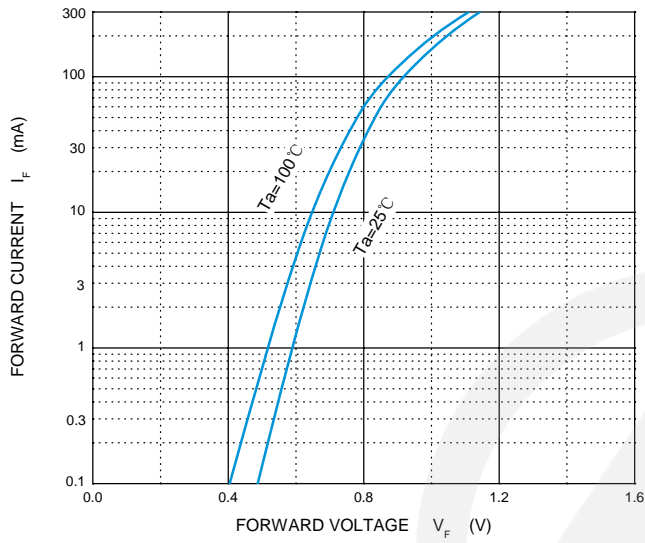

Fig.2 Reverse Characteristics

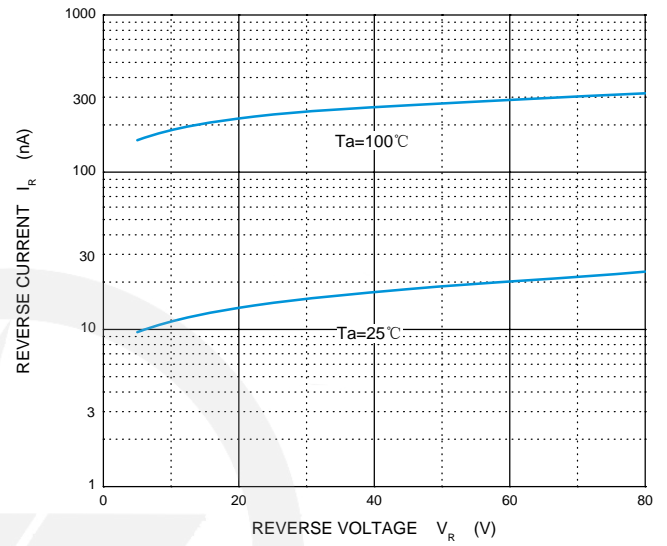

Fig.3 Capacitance Characteristics

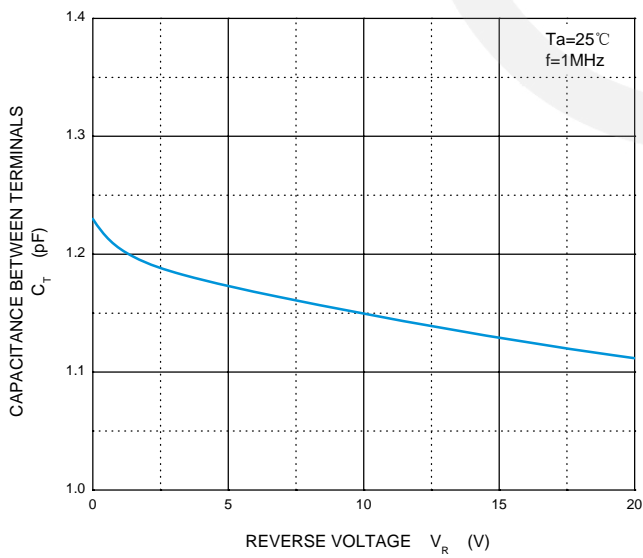
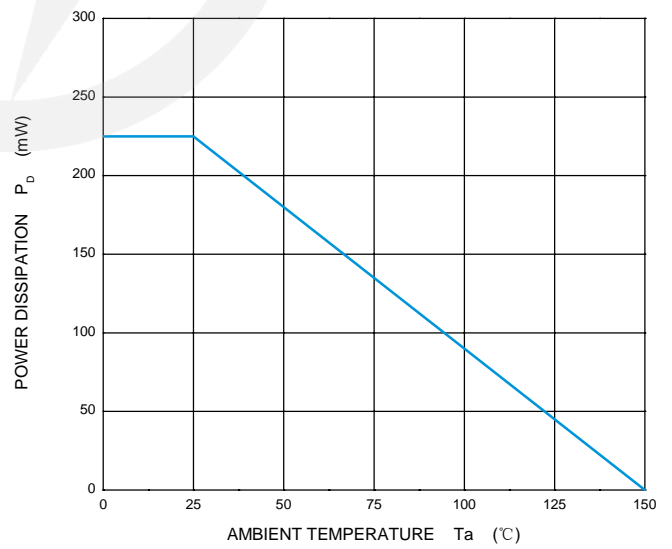
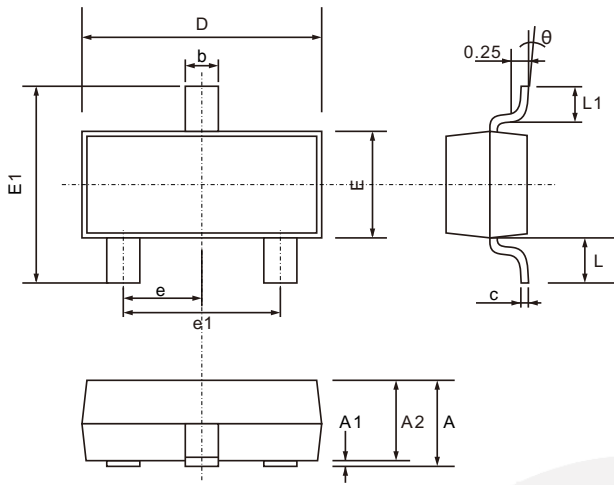

Fig.4 Power Derating Curve



SOT-23 Package Outline

Unit: mm



SYMBOL	DIMENSIONS	
	MIN.	MAX.
A	0.900	1.200
A1	0.000	0.100
A2	0.900	1.050
b	0.300	0.500
c	0.080	0.200
D	2.700	3.100
E	1.200	1.400
E1	2.200	2.600
e	0.950 TYP.	
e1	1.750	2.050
L	0.550 TYP.	
L1	0.300	0.500
θ	0°	8°

SOT-23 Suggested Pad Layout

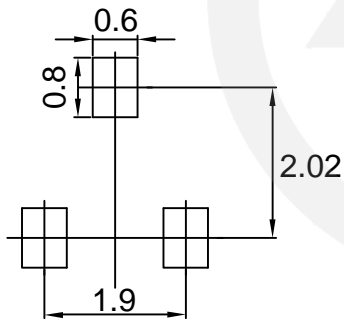

Note:
 1. Controlling dimension: in millimeters.
 2. General tolerance: ± 0.05mm
 3. The pad layout is for reference purpose only.

Carrier Tape Dimensions

Unit : mm

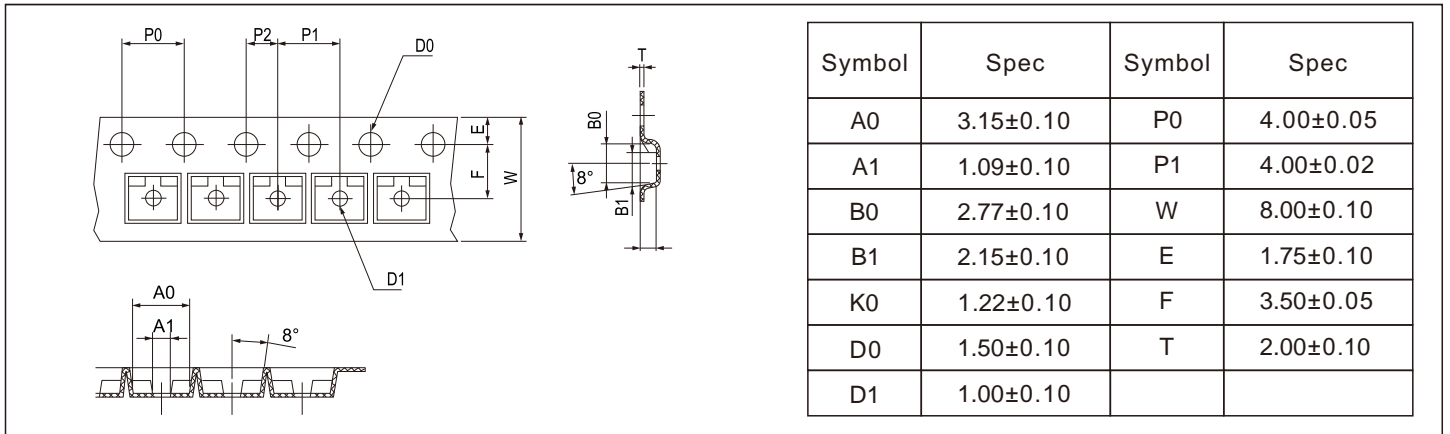

Reel Dimensions

Unit : mm

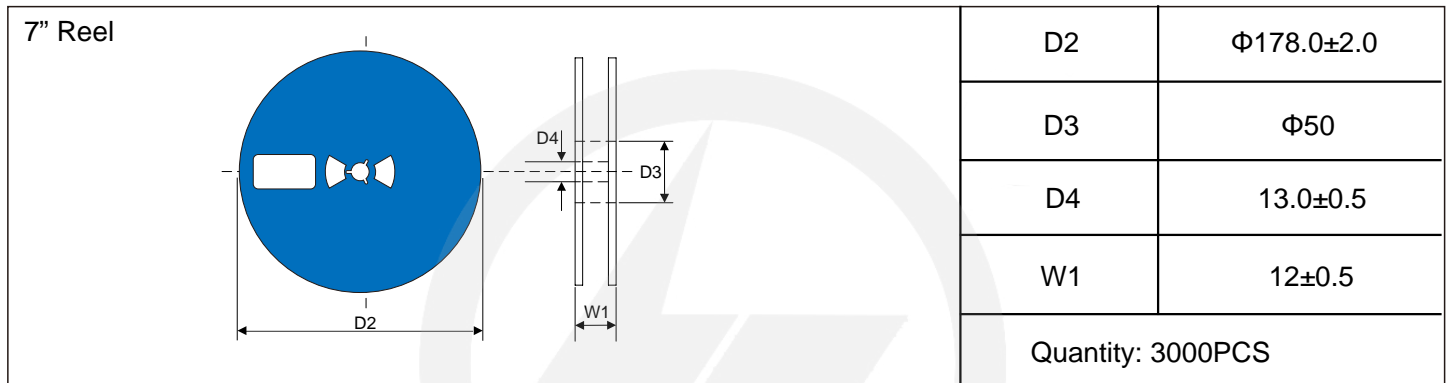

Reel Dimensions

Unit : mm

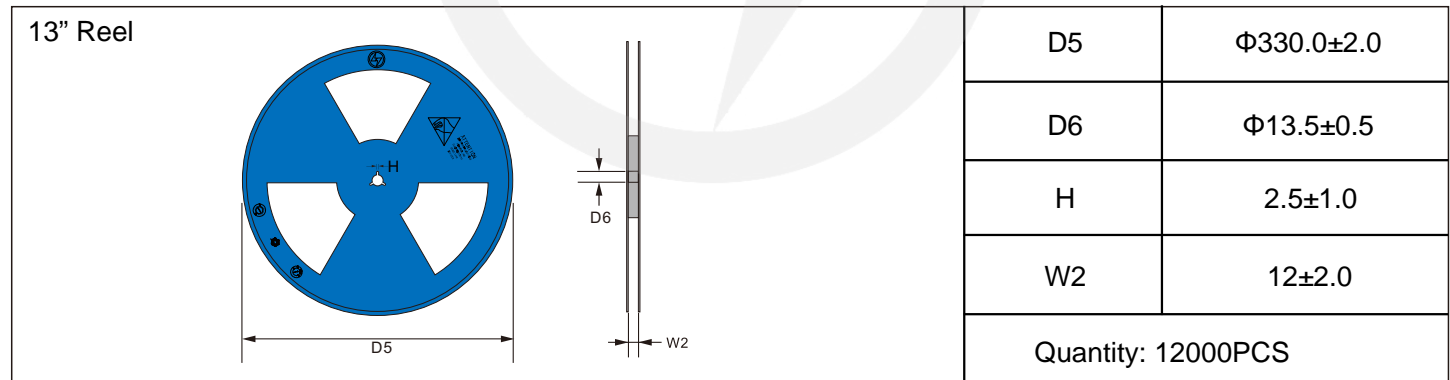

Packaging

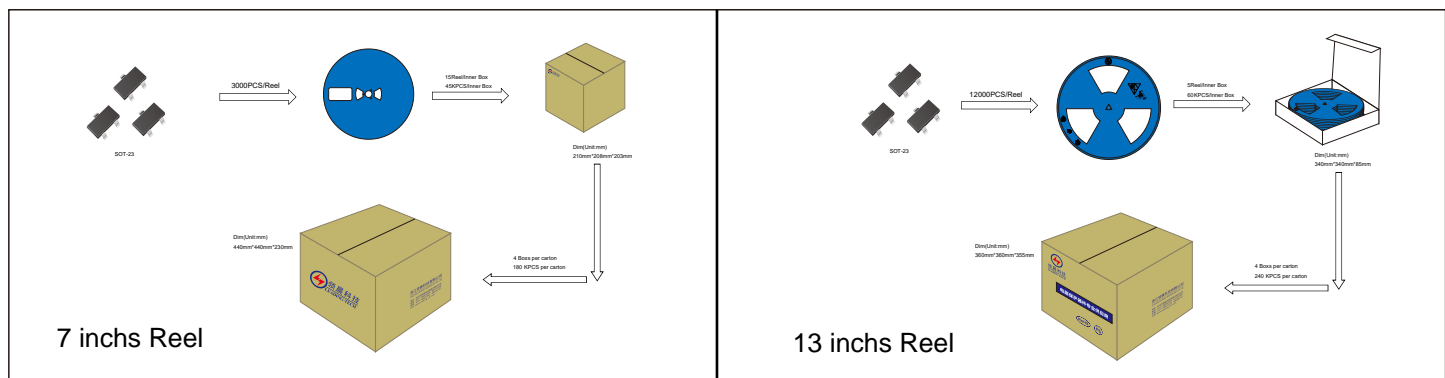



Recommended Soldering Conditions



Recommended Conditions

Profile Feature	Pb-Free Assembly
Average ramp-up rate (T _L to T _P)	3°C/second max.
Preheat	
-Temperature Min (T _{S min})	150°C
-Temperature Max (T _{S max})	200°C
-Time (min to max) (t _s)	60-180 seconds
T _{S max} to T _L	
-Ramp-up Rate	3°C/second max.
Time maintained above:	
-Temperature (T _L)	217°C
-Time (t _L)	60-150 seconds
Peak Temperature (T _P)	260°C
Time within 5°C of actual Peak Temperature (t _p)	20-40 seconds
Ramp-down Rate	6°C/second max.
Time 25°C to Peak Temperature	8 minutes max.

Important Notice and Disclaimer

Leading-Tech reserves the right to make changes to this document and its products and specifications at any time without notice.

Customers should obtain and confirm the latest product information and specifications before final design, purchase or use.

Leading-Tech makes no warranty, representation or guarantee regarding the suitability of its products for any particular purpose, not does Leading-Tech assume any liability for application assistance or customer product design.

Leading-Tech does not warrant or accept any liability with products which are purchase or used for any unintended or unauthorized application.

No license is granted by implication or otherwise under any intellectual property rights of Leading-Tech.

Leading-Tech products are not authorized for use as critical components in life support devices or systems without express written approval of Leading-Tech.

Version Update Information

Series NO.	Enactment/Revision Date	Effective Date	Version	Revision Content	Revision Reason	Revision Person	Note
01	2024.04.18	2024.04.18	3.0	New file	/	Ding	
02	2026.03.04	2026.03.04	3.1	Package outline E1(max)=2.6mm	/	Ding	