

## Schottky Barrier Rectifiers

### Features

- Low Forward Voltage Drop
- Fast Switching Time
- Surface Mount Package Ideally Suited for Automated Insertion
- Lead free in comply with EU RoHS 2011/65/EU directives



### Mechanical Data

- Case:SOD-523
- Polarity:Color band denotes cathode end

### Ordering Information

Part Number	Marking	Shipping	Reel
LTS40T-TR3	40	3000PCS Tape&Reel	7 inches
LTS40T-TR10	40	10000PCS Tape&Reel	7 inches

### Maximum Ratings and Electrical Characteristics

Parameter	Symbol	LTS40T	Unit
DC Reverse Voltage	$V_R$	40	V
Forward Continuous Current	$I_F$	200	mA
Power dissipation	$P_D$	150	mW
Breakdown Voltage	$I_R = 100\mu A$ $V_R$	40(Min)	V
Forward Voltage	$I_F = 1.0\text{ mA}$ $I_F = 40\text{ mA}$ $V_F$	0.38(Max) 1.00(Max)	V
Peak Reverse Current	$V_R = 30\text{ V}$ $I_R$	0.5(Max)	$\mu A$
Typical Junction Capacitance	$V_R = 0\text{ V}, f = 1\text{ MHz}$ $C_T$	5	pF
Reverse Recovery Time	$I_F = I_R = 5\text{ mA}$ , $I_{rr} = 0.1 \times I_R$ , $R_L = 100\Omega$ $t_{rr}$	5	ns
Junction Temperature	$T_j$	125	$^{\circ}C$
Storage Temperature	$T_{stg}$	-55 ~ +150	$^{\circ}C$



### Characteristics Curves

Fig.1 Power Derating Curve

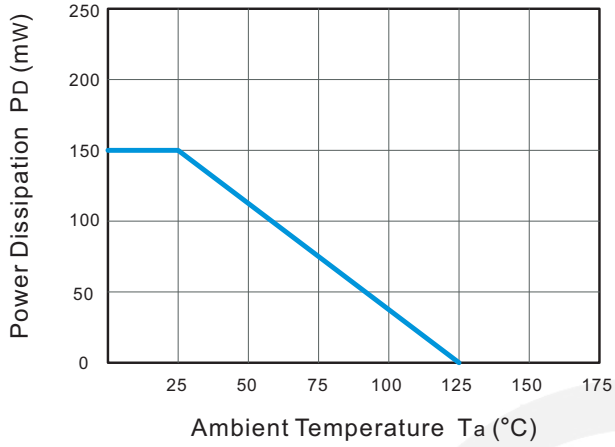

Fig.2 Typical Instantaneous Reverse Characteristics

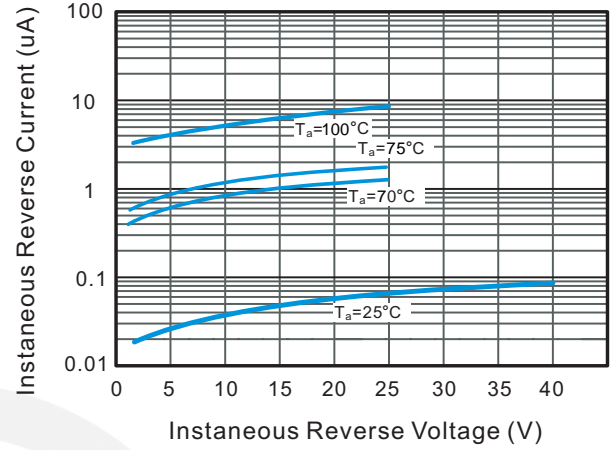

Fig.3 Typical Forward Characteristic

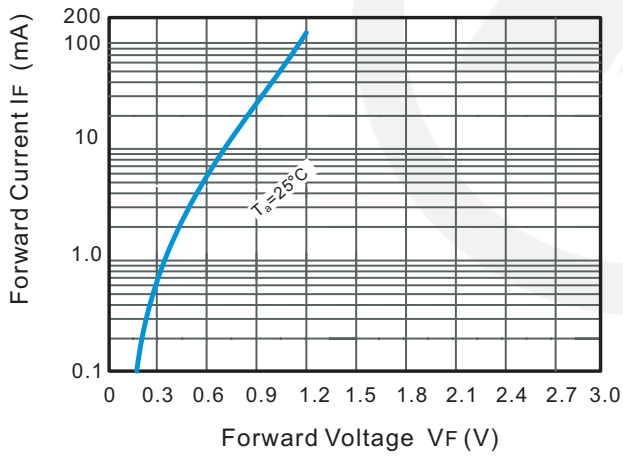
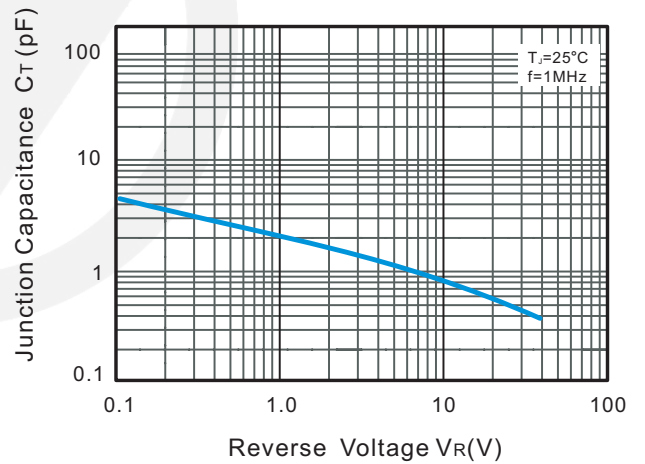
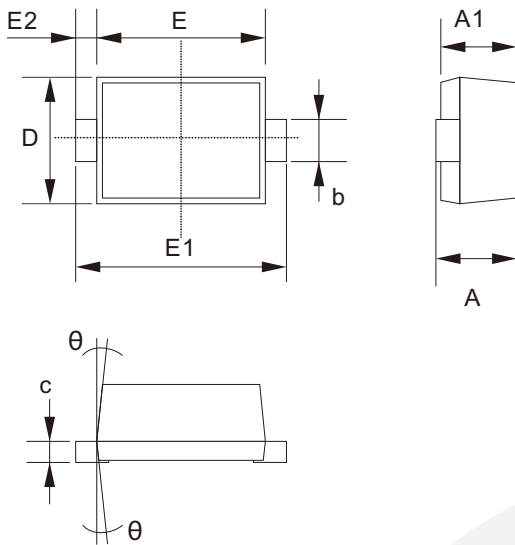

Fig.4 Typical Junction Capacitance



**SOD-523 Package Outline**

Unit: mm



SYMBOL	DIMENSIONS	
	MIN.	MAX.
A	0.500	0.770
A1	0.500	0.700
b	0.250	0.380
c	0.070	0.200
D	0.700	0.900
E	1.100	1.300
E1	1.500	1.700
E2	0.200 REF	
θ	7° REF	

**SOD-523 Suggested Pad Layout**

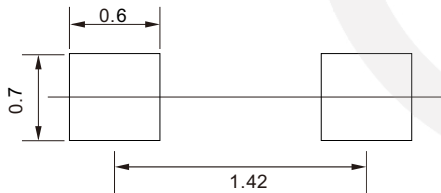

- Note:
1. Controlling dimension: in millimeters.
  2. General tolerance:  $\pm 0.05$  mm.
  3. The pad layout is for reference purposes only.

**Carrier Tape Dimensions**

Unit : mm

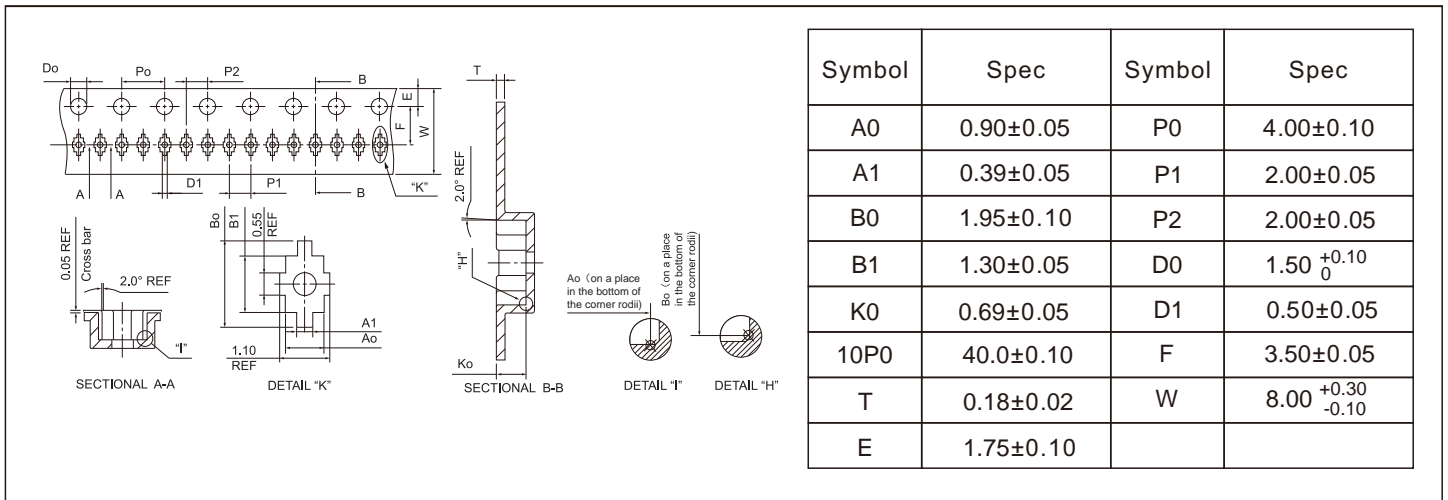

**Reel Dimensions**

Unit : mm

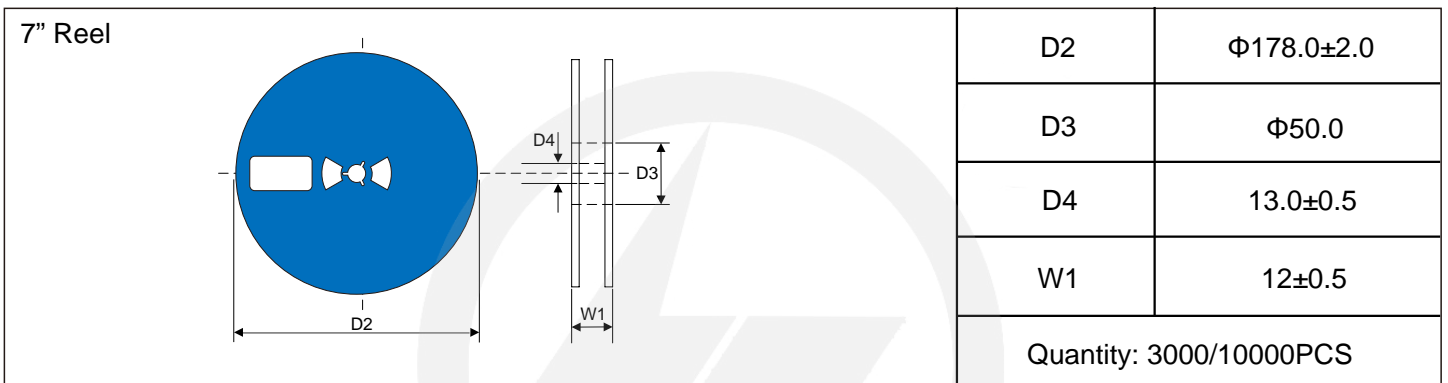

**Packaging**

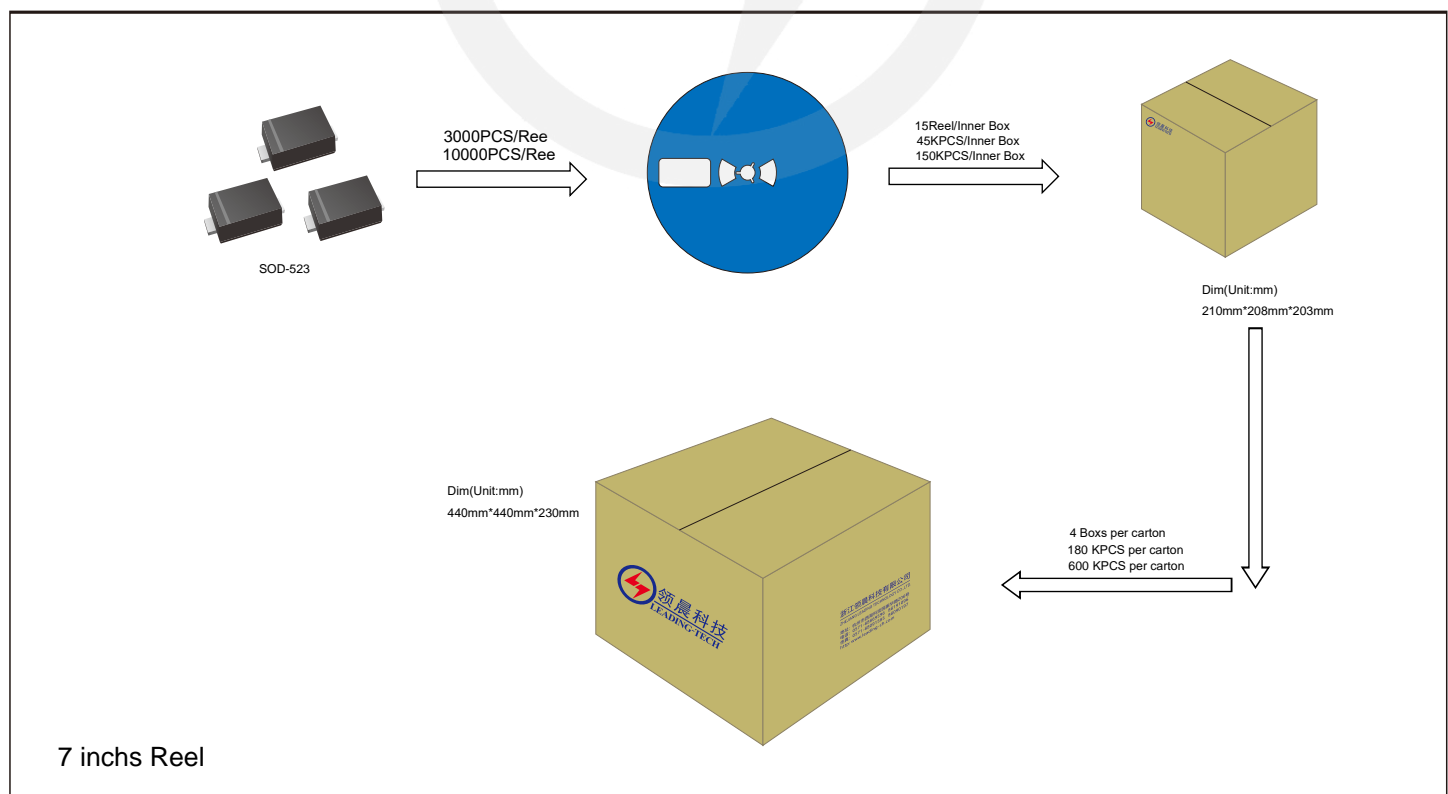



Recommended Soldering Conditions

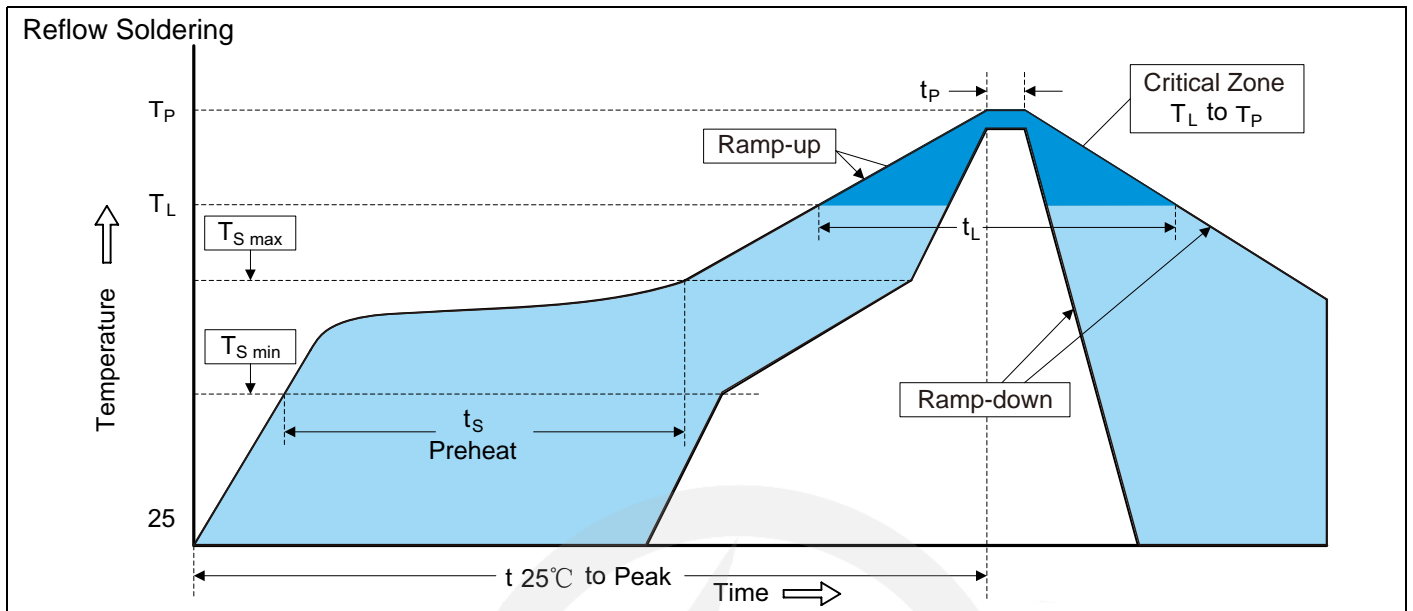

Recommended Conditions

Profile Feature	Pb-Free Assembly
Average ramp-up rate (T <sub>L</sub> to T <sub>P</sub> )	3°C/second max.
Preheat	
-Temperature Min (T <sub>S min</sub> )	150°C
-Temperature Max (T <sub>S max</sub> )	200°C
-Time (min to max) (t <sub>s</sub> )	60-180 seconds
T <sub>S max</sub> to T <sub>L</sub>	
-Ramp-up Rate	3°C/second max.
Time maintained above:	
-Temperature (T <sub>L</sub> )	217°C
-Time (t <sub>L</sub> )	60-150 seconds
Peak Temperature (T <sub>P</sub> )	260°C
Time within 5°C of actual Peak Temperature (t <sub>p</sub> )	20-40 seconds
Ramp-down Rate	6°C/second max.
Time 25°C to Peak Temperature	8 minutes max.

## Important Notice and Disclaimer

Leading-Tech reserves the right to make changes to this document and its products and specifications at any time without notice.

Customers should obtain and confirm the latest product information and specifications before final design, purchase or use.

Leading-Tech makes no warranty, representation or guarantee regarding the suitability of its products for any particular purpose, not does Leading-Tech assume any liability for application assistance or customer product design.

Leading-tech does not warrant or accept any liability with products which are purchase or used for any unintended or unauthorized application.

No license is granted by implication or otherwise under any intellectual property rights of Leading-Tech.

Leading-Tech products are not authorized for use as critical components in life support devices or systems without express written approval of Leading-tech.

## Version Update Information

Series NO.	Enactment/Revision Date	Effective Date	Version	Revision content	Revision Reason	Revision Person	Note
01	2024.5.5	2024.5.5	3.0	New File	/	Ding	