

Schottky Barrier Diode

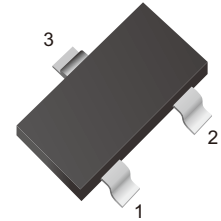



Features

- Low Forward Voltage
- Fast Switching
- Lead free in comply with EU RoHS 2011/65/EU directives
- Moisture Sensitivity Level 1
- ESD: 2000V(HBM)

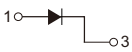

Mechanical Data

- Case: SOT-23
- Approx. Weight: 8.1mg

LTS40	LTS40-04	LTS40-05	LTS40-06
			
MARKING:43	MARKING:44	MARKING:45	MARKING:46

Ordering Information

Part Number	Shipping	Reel
LTS40-04-05-06-TR3	3000PCS Tape&Reel	7 inches
LTS40-04-05-06-TR12	12000PCS Tape&Reel	13 inches

Maximum Ratings (Ta=25 unless otherwise noted)

Parameter	Symbol	Value	Unit
DC Blocking Voltage	V _R		
Working Peak Reverse Voltage	V _{RWM}	40	V
Peak Repetitive Peak Reverse Voltage	V _{RRM}		
Forward continuous current	I _{FM}	200	mA
Non-Repetitive Peak Forward Surge Current @t=8.3ms	I _{FSM}	600	mA
Power Dissipation	P _D	200	mW
Thermal Resistance Junction to Air ⁽¹⁾	R _{thJA}	500	°C/W
Thermal Resistance Junction to Case ⁽¹⁾	R _{thJC}	200	°C/W
Junction Temperature	T _j	125	°C
Storage Temperature Range	T _{stg}	-55 to +150	°C
Operating Temperature Range	T _{op}	-55 to +125	°C

Note 1: The data tested by surface mounted on a 1 inch FR-4 board with 1OZ copper

Electrical Characteristics ($T_a=25$ unless otherwise Specified)

Parameter	Symbol	Test conditions	Min	Max	Unit
Reverse breakdown voltage	V_{BR}	$I_R=10\mu A$	40		V
Reverse voltage leakage current	I_R	$V_R=30V$		0.2	μA
Forward voltage	V_F	$I_F=1mA$ $I_F=40mA$		0.38 1.0	V
Diode capacitance	C_D	$V_R=0, f=1MHz$		5	pF
Reverse recovery time	t_{rr}	$I_{rr}=1mA, I_F=I_R=10mA$ $R_L=100\Omega$		5	ns

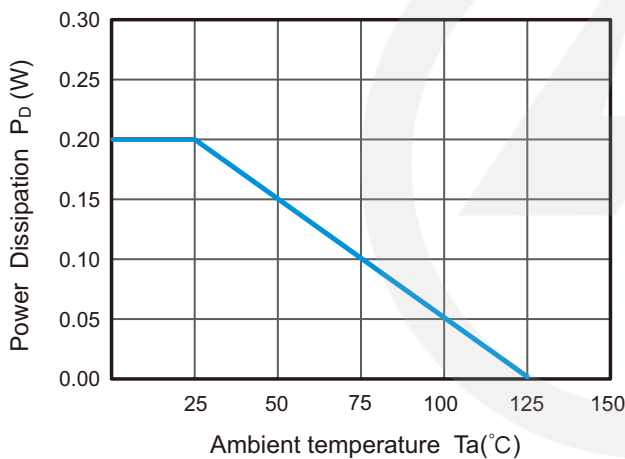
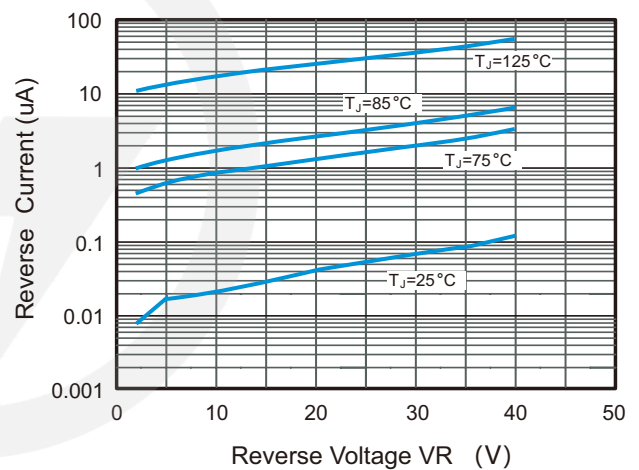
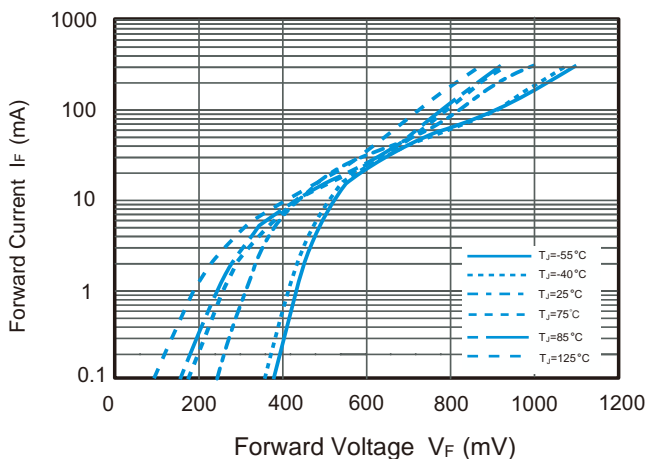
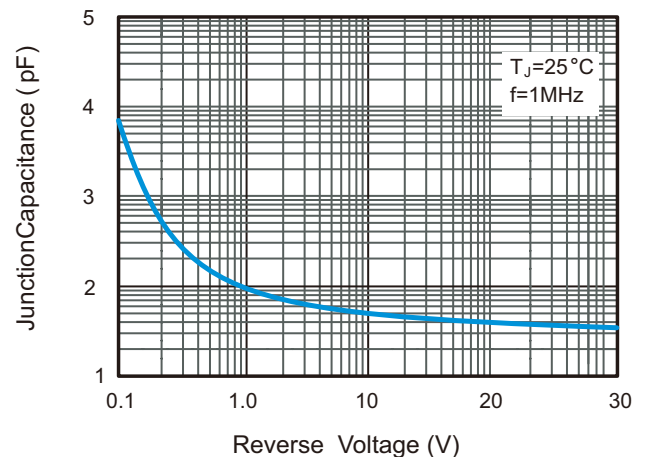
Characteristics Curves
Fig.1 Power Derating Curve

Fig.2 Typical Reverse Characteristics

Fig.3 Forward Characteristics

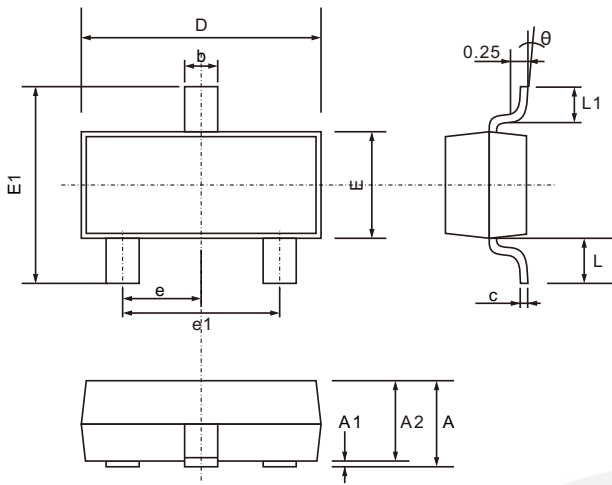
Fig.4 Typical Junction Capacitance

SOT-23 Package Outline

Unit: mm



SYMBOL	DIMENSIONS	
	MIN.	MAX.
A	0.900	1.200
A1	0.000	0.100
A2	0.900	1.050
b	0.300	0.500
c	0.080	0.200
D	2.700	3.100
E	1.200	1.400
E1	2.200	2.600
e	0.950 TYP.	
e1	1.750	2.050
L	0.550 TYP.	
L1	0.300	0.500
θ	0°	8°

SOT-23 Suggested Pad Layout

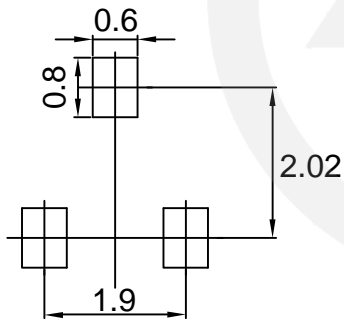

Note:
 1. Controlling dimension: in millimeters.
 2. General tolerance: ± 0.05 mm
 3. The pad layout is for reference purpose only.

Carrier Tape Dimensions

Unit : mm

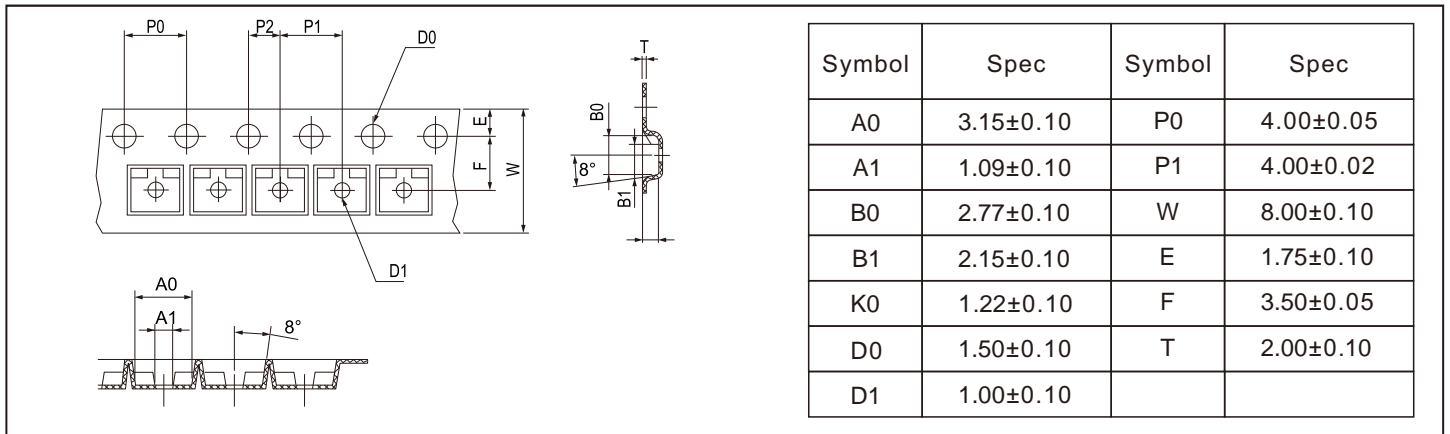

Reel Dimensions

Unit : mm

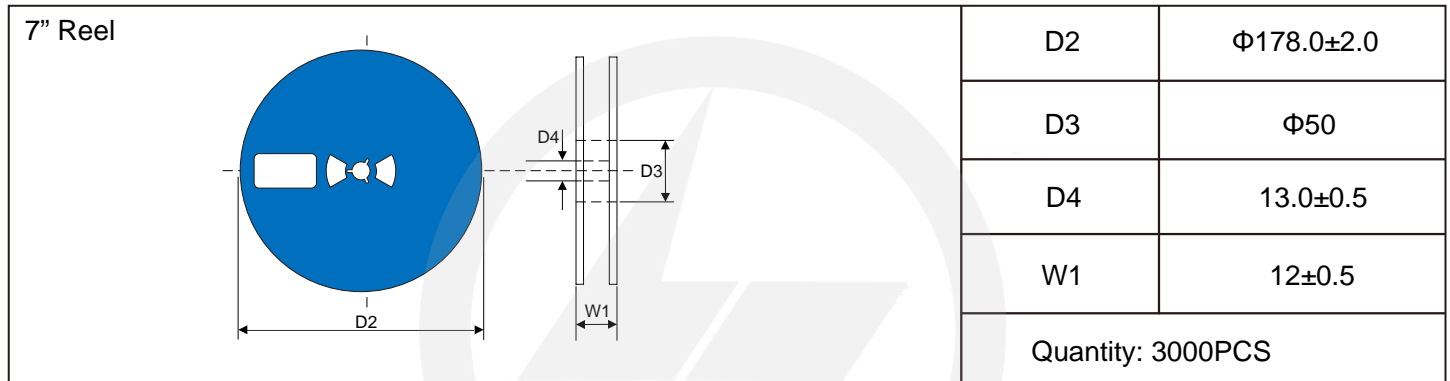

Reel Dimensions

Unit : mm

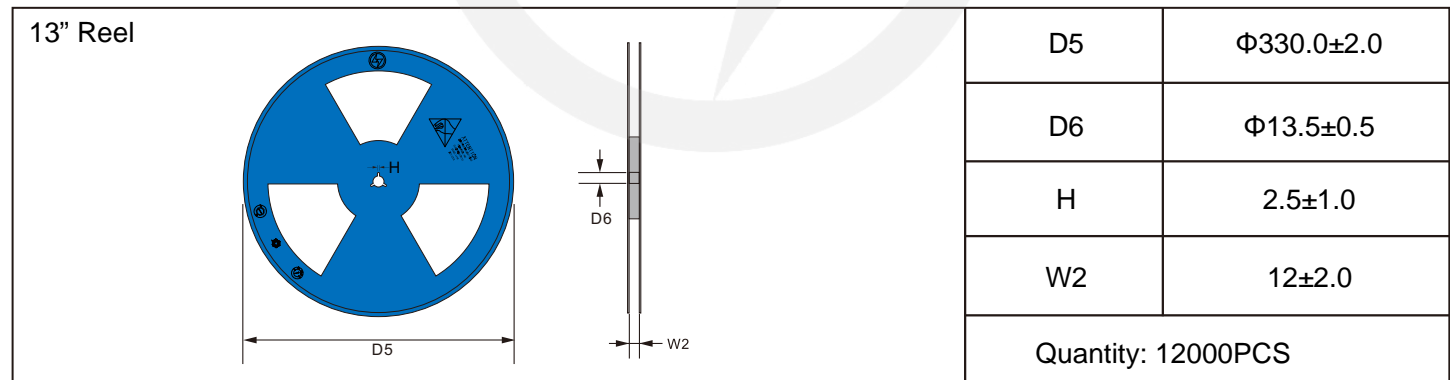

Packaging

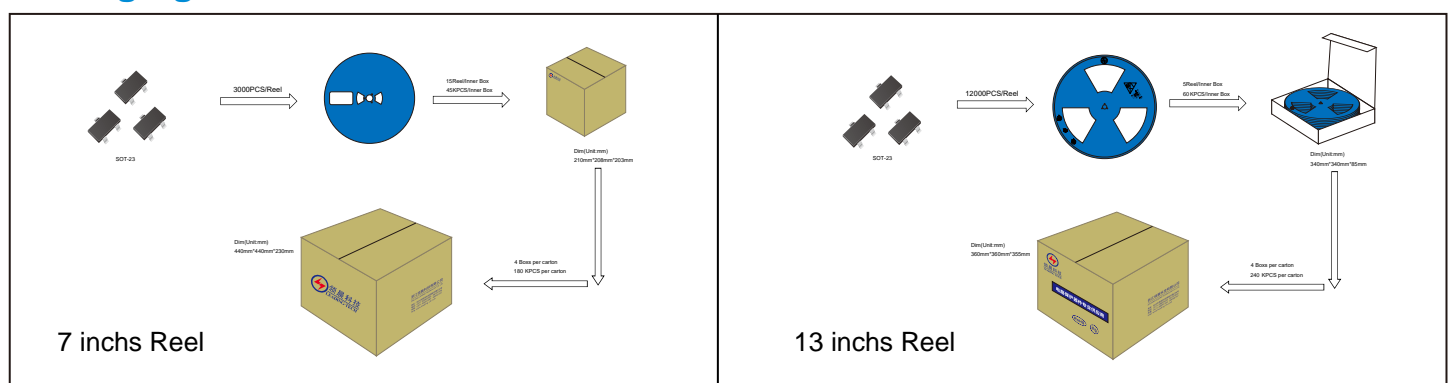



Recommended Soldering Conditions



Recommended Conditions

Profile Feature	Pb-Free Assembly
Average ramp-up rate (T_L to T_P)	3°C/second max.
Preheat	
-Temperature Min ($T_{S\ min}$)	150°C
-Temperature Max ($T_{S\ max}$)	200°C
-Time (min to max) (t_s)	60-180 seconds
$T_{S\ max}$ to T_L	
-Ramp-up Rate	3°C/second max.
Time maintained above:	
-Temperature (T_L)	217°C
-Time (t_L)	60-150 seconds
Peak Temperature (T_P)	260°C
Time within 5°C of actual Peak Temperature (t_p)	20-40 seconds
Ramp-down Rate	6°C/second max.
Time 25°C to Peak Temperature	8 minutes max.

Important Notice and Disclaimer

Leading-Tech reverses the right to make changes to this document and its products and specifications at any time without notice.

Customers should obtain and confirm the latest product information and specifications before final design, purchase or use.

Leading-Tech makes no warranty, representation or guarantee regarding the suitability of its products for any particular purpose, not does Leading-Tech assume any liability for application assistance or customer product design.

Leading-Tech does not warrant or accept any liability with products which are purchase or used for any unintended or unauthorized application.

No license is granted by implication or otherwise under any intellectual property rights of Leading-Tech.

Leading-Tech products are not authorized for use as critical components in life support devices or systems without express written approval of Leading-Tech.

Version Update Information

Series NO.	Enactment/Revision Date	Effective Date	Version	Revision Content	Revision Reason	Revision Person	Note
01	2024.03.18	2024.03.18	3.0	New file	/	Ding	
02	2025.03.13	2025.03.13	3.1	Delete $V_R=40V$ $I_F=200mA$	/	Ding	
03	2026.01.20	2026.01.20	3.2	1. Add Maximum Ratings parameter 2. Add feature description	/	Ding	
04	2026.02.03	2026.02.03	3.3	Modify VF and I_R curves	/	Ding	
05	2026.03.04	2026.03.04	3.4	1.Update Characteristics Curves 2.Package outline $E1(max)=2.6mm$	/	Ding	