

Schottky Barrier Diodes

Features

- Extremely Fast Switching Speed
- Lead free in comply with EU RoHS 2011/65/EU directives

Mechanical Data

- Case: SOT-23
- Approx. Weight: 8.1mg

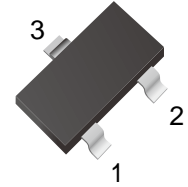

LTS23KL1	LTS23KL2	LTS23KL3	LTS23KL4	LTS23KL5
MARKING:KL1	MARKING:KL2	MARKING:KL3	MARKING:KL4	MARKING:KL5

Ordering Information

Part Number	Shipping	Reel
LTS23KL1/2/3/4/5-TR3	3000PCS Tape&Reel	7 inches
LTS23KL1/2/3/4/5-TR12	12000PCS Tape&Reel	13 inches

Maximum Ratings (Ta=25 unless otherwise noted)

Parameter	Symbol	Value	Unit
Peak Repetitive Reverse Voltage	V_{RRM}	30	V
Working Peak Reverse Voltage	V_{RWM}		
DC Blocking Voltage	V_R		
Forward Continuous Current	I_{FM}	200	mA
Non-repetitive Peak Forward Surge Current @ t=8.3ms	I_{FSM}	600	mA
Repetitive Peak Forward Current @ t≤1s, δ≤0.5	I_{FRM}	300	mA
Power Dissipation	P_D	200	mW
Thermal Resistance from Junction to Ambient	R_{thJA}	500	°C/W
Operating Junction Temperature Range	T_j	-40~ +125	°C
Storage Temperature Range	T_{stg}	-55 ~ +150	°C



Electrical Characteristics (Ta=25°C unless otherwise specified)

Parameter	Symbol	Test conditions	Min	Typ	Max	Unit
Reverse voltage	V_{BR}	$I_R=100\mu A$	30			V
Reverse current	I_R	$V_R=25V$			2	μA
Forward voltage	V_F	$I_{F1}=0.1mA$			0.24	V
		$I_{F2}=1mA$			0.32	V
		$I_{F3}=10mA$			0.40	V
		$I_{F4}=30mA$			0.50	V
		$I_{F5}=100mA$			1	V
Diode capacitance	C_D	$V_R=4V, f=1MHz$		10		pF
Reverse recovery time	T_{rr}	$I_F = I_R=10mA,$ $I_{rr}=0.1 \times I_R, R_L=100\Omega$			5	ns

Characteristics Curves

Fig.1 Power Derating Curve

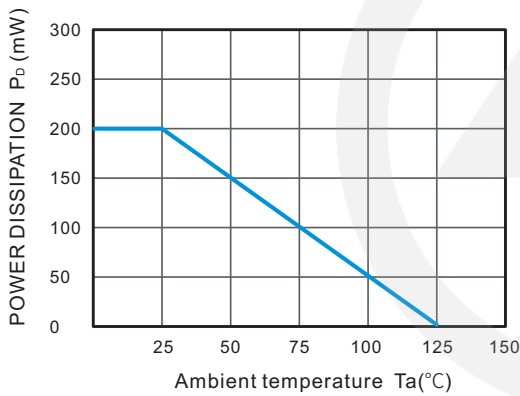

Fig.2 Reverse Characteristics

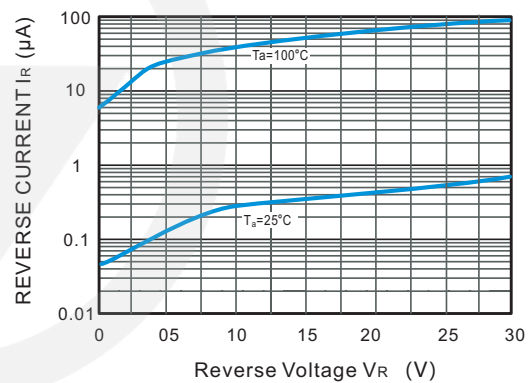

Fig.3 Forward Characteristics

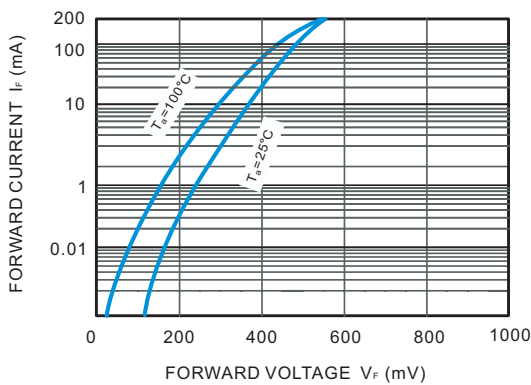
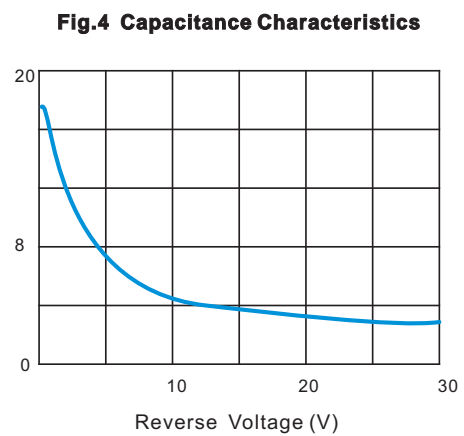
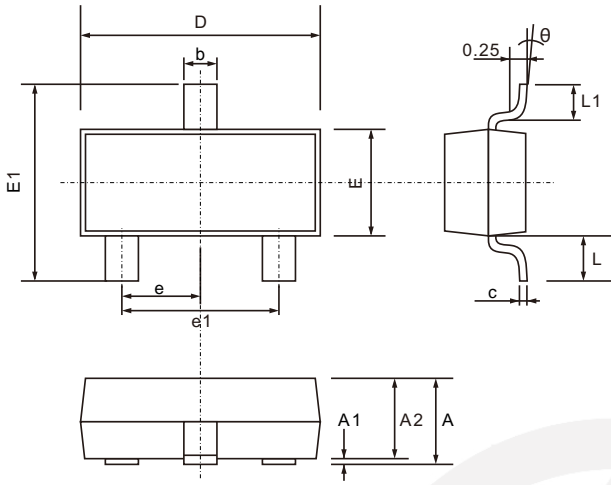

Fig.4 Capacitance Characteristics



SOT-23 Package Outline

Unit: mm



SYMBOL	DIMENSIONS	
	MIN.	MAX.
A	0.900	1.200
A1	0.000	0.100
A2	0.900	1.050
b	0.300	0.500
c	0.080	0.200
D	2.700	3.100
E	1.200	1.400
E1	2.200	2.600
e	0.950 TYP.	
e1	1.750	2.050
L	0.550 TYP.	
L1	0.300	0.500
θ	0°	8°

SOT-23 Suggested Pad Layout

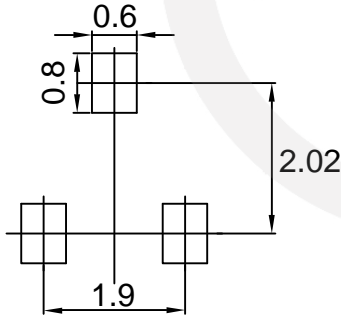

- Note:
1. Controlling dimension: in millimeters.
 2. General tolerance: $\pm 0.05\text{mm}$
 3. The pad layout is for reference purpose only.

Carrier Tape Dimensions

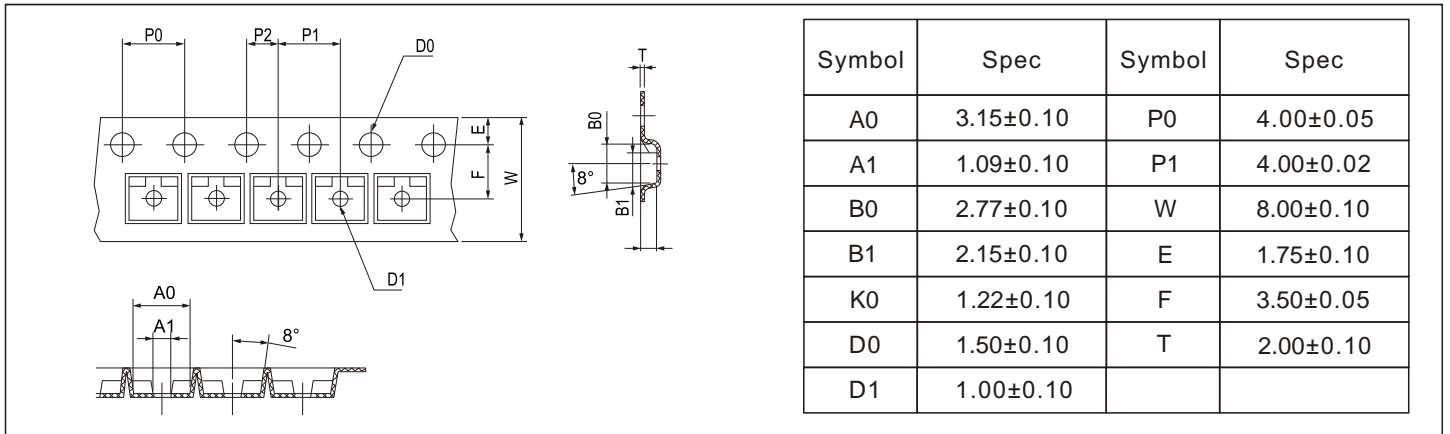

Reel Dimensions

Unit : mm

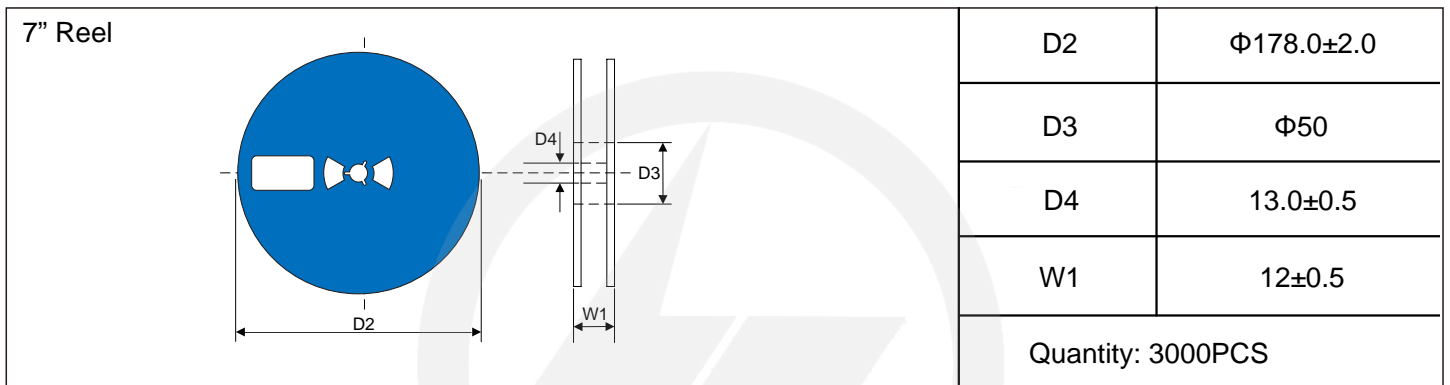

Reel Dimensions

Unit : mm

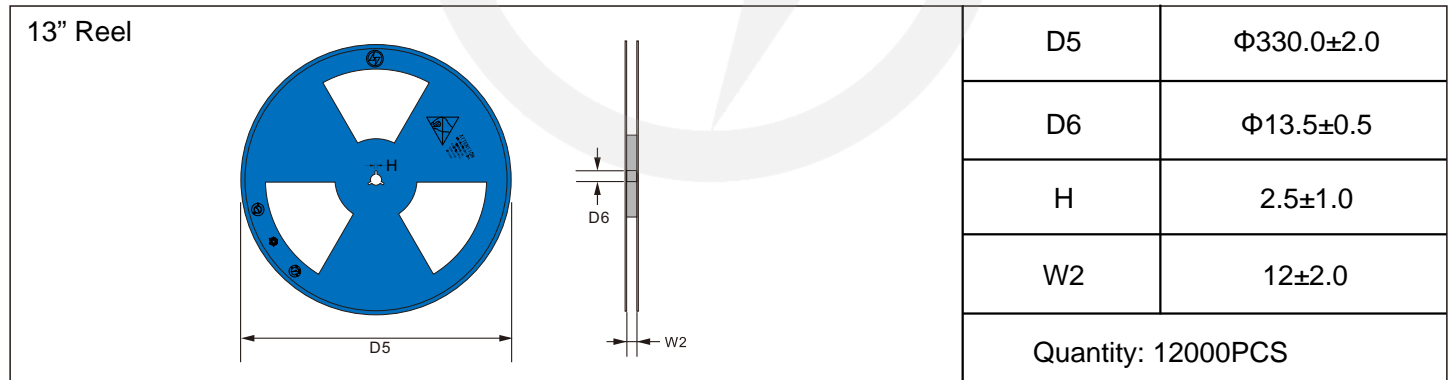

Packaging

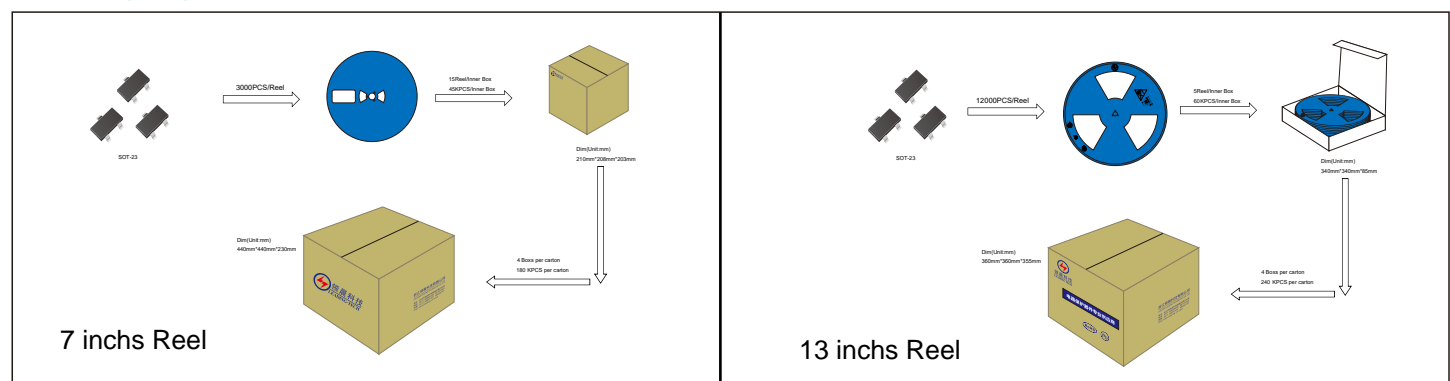



Recommended Soldering Conditions



Recommended Conditions

Profile Feature	Pb-Free Assembly
Average ramp-up rate (T _L to T _P)	3°C/second max.
Preheat	
-Temperature Min (T _{S min})	150°C
-Temperature Max (T _{S max})	200°C
-Time (min to max) (t _s)	60-180 seconds
T _{S max} to T _L	
-Ramp-up Rate	3°C/second max.
Time maintained above:	
-Temperature (T _L)	217°C
-Time (t _L)	60-150 seconds
Peak Temperature (T _P)	260°C
Time within 5°C of actual Peak Temperature (t _p)	20-40 seconds
Ramp-down Rate	6°C/second max.
Time 25°C to Peak Temperature	8 minutes max.

Important Notice and Disclaimer

Leading-Tech reverses the right to make changes to this document and its products and specifications at any time without notice.

Customers should obtain and confirm the latest product information and specifications before final design, purchase or use.

Leading-Tech makes no warranty, representation or guarantee regarding the suitability of its products for any particular purpose, not does Leading-Tech assume any liability for application assistance or customer product design.

Leading-Tech does not warrant or accept any liability with products which are purchase or used for any unintended or unauthorized application.

No license is granted by implication or otherwise under any intellectual property rights of Leading-Tech.

Leading-Tech products are not authorized for use as critical components in life support devices or systems without express written approval of Leading-Tech.

Version Update Information

Series NO.	Enactment/Revision Date	Effective Date	Version	Revision Content	Revision Reason	Revision Person	Note
01	2024.03.15	2024.03.15	3.0	New file	/	Ding	
02	2025.05.30	2025.05.30	3.1	Modify the coordinates in Fig. 3	/	Ding	
03	2026.03.04	2026.03.04	3.2	Package outline E1(max)=2.6mm	/	Ding	