

Surface Mount Fast Recovery Rectifier

Features

- For surface mounted applications
- Low profile package
- Glass Passivated Chip Junction
- Easy to pick and place
- Fast reverse recovery time
- Lead free in comply with EU RoHS 2011/65/EU directives
- The plastic package carries Underwriters Laboratory Flammability Classification 94V-0



Mechanical Data

- Case: SOD-123FL
- Terminals: Solderable per MIL-STD-750, Method 2026
- Polarity: Color band denotes cathode end

Ordering Information

| Part Number | Shipping | Reel |
|---------------------------|--------------------|-----------|
| LTR101L THRU LTR107L-TR3 | 3000PCS Tape&Reel | 7 inches |
| LTR101L THRU LTR107L-TR12 | 12000PCS Tape&Reel | 13 inches |

Maximum Ratings and Electrical Characteristics

Ratings at 25 °C ambient temperature unless otherwise specified. Single phase, half wave, 60 Hz, resistive or inductive load. For capacitive load, derate current by 20%.

| Parameter | Symbol | LTR101L | LTR102L | LTR103L | LTR104L | LTR105L | LTR106L | LTR107L | Unit |
|---|-----------------|------------|---------|---------|---------|---------|---------|---------|--------------------|
| Maximum Repetitive Peak Reverse Voltage | V_{RRM} | 50 | 100 | 200 | 400 | 600 | 800 | 1000 | V |
| Maximum RMS voltage | V_{RMS} | 35 | 70 | 140 | 280 | 420 | 560 | 700 | V |
| Maximum DC Blocking Voltage | V_{DC} | 50 | 100 | 200 | 400 | 600 | 800 | 1000 | V |
| Maximum Average Forward Rectified Current at $T_c = 125\text{ }^\circ\text{C}$ | $I_{F(AV)}$ | 1 | | | | | | | A |
| Peak Forward Surge Current 8.3 ms Single Half Sine Wave Superimposed on Rated Load | I_{FSM} | 30 | | | | | | | A |
| Maximum Forward Voltage at 1 A | V_F | 1.3 | | | | | | | V |
| Maximum DC Reverse Current $T_a = 25\text{ }^\circ\text{C}$ at Rated DC Blocking Voltage $T_a = 125\text{ }^\circ\text{C}$ | I_R | 5 100 | | | | | | | μA |
| Typical Junction Capacitance at $V_R=4\text{V}$, $f=1\text{MHz}$ | C_j | 15 | | | | | | | pF |
| Maximum Reverse Recovery Time (Note1) | t_{rr} | 150 | | | | 250 | 500 | | ns |
| Typical Thermal Resistance (Note2) | $R_{\theta JA}$ | 85 | | | | | | | $^\circ\text{C/W}$ |
| Operating and Storage Temperature Range | T_j, T_{stg} | -55 ~ +150 | | | | | | | $^\circ\text{C}$ |

Note: (1) Measured with $I_F = 0.5\text{ A}$, $I_R = 1\text{ A}$, $I_{rr} = 0.25\text{ A}$.

(2) P.C.B. mounted with 2.0" X 2.0" (5 cm X 5 cm) copper pad areas.



Characteristic Curves

Fig1. Forward Current Derating Curve

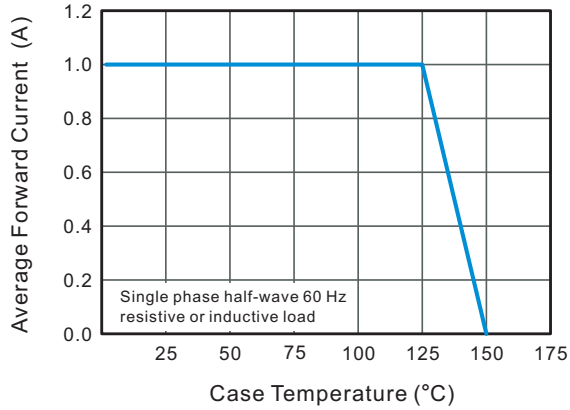

Fig2. Typical Reverse Characteristics

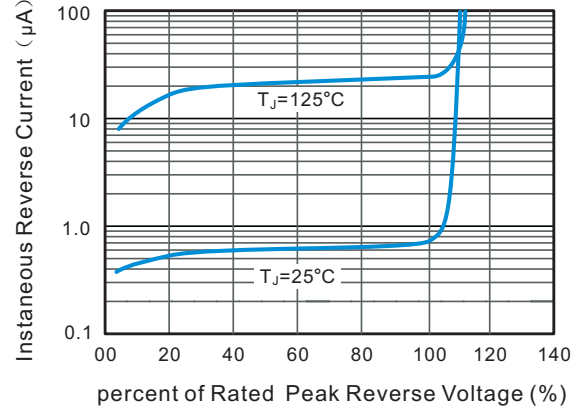

Fig3. Typical Instaneous Forward Characteristics

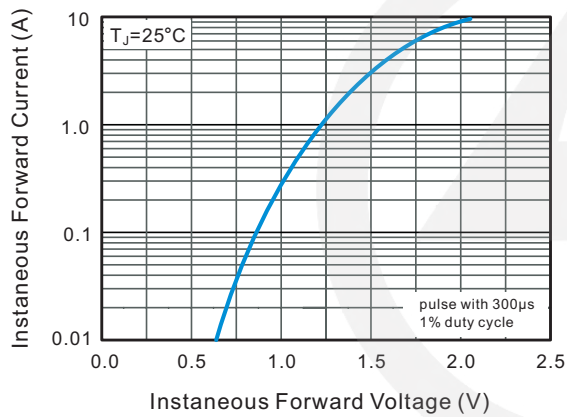

Fig4. Typical Junction Capacitance

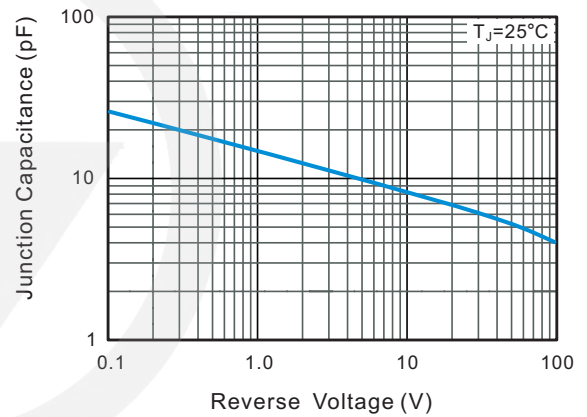
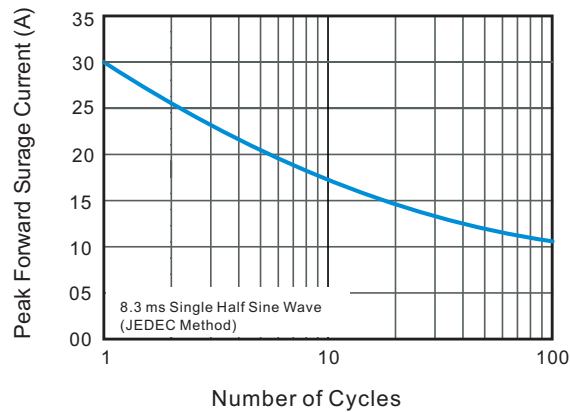
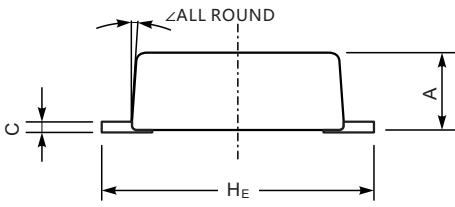

Fig5. Maximum Non-Repetitive Peak Forward Surge Current



SOD-123FL Package Outline

Unit: mm



| SYMBOL | DIMENSIONS | |
|----------------|------------|------|
| | MIN. | MAX. |
| A | 0.9 | 1.35 |
| C | 0.12 | 0.20 |
| D | 2.6 | 2.9 |
| E | 1.75 | 1.95 |
| e | 0.8 | 1.1 |
| g | 0.7 | 0.9 |
| H _E | 3.5 | 3.8 |
| ∠ | 7° | |

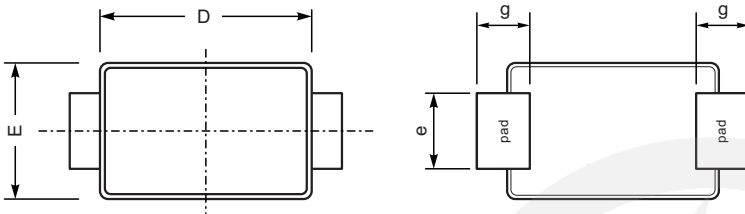

SOD-123FL Suggested Pad Layout

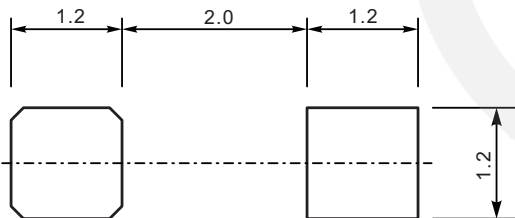

- Note:
1. Controlling dimension: in millimeters.
 2. General tolerance: $\pm 0.05\text{mm}$
 3. The pad layout is for reference purpose only.

Marking

| Type number | Marking code |
|-------------|--------------|
| LTR101L | F2 |
| LTR102L | F2 |
| LTR103L | F2 |
| LTR104L | F2 |
| LTR105L | F3 |
| LTR106L | F7 |
| LTR107L | F7 |

Carrier Tape Dimensions

Unit : mm

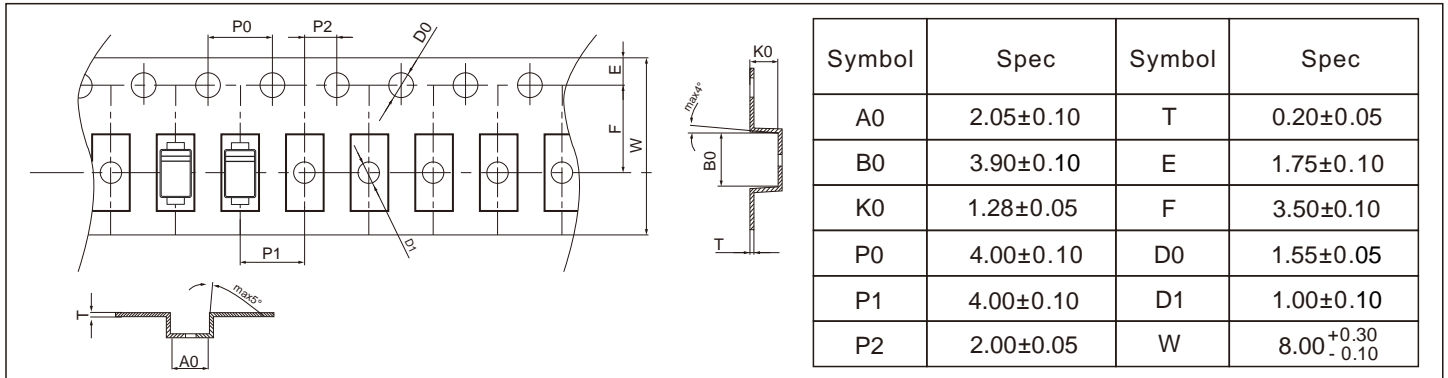

Reel Dimensions

Unit : mm

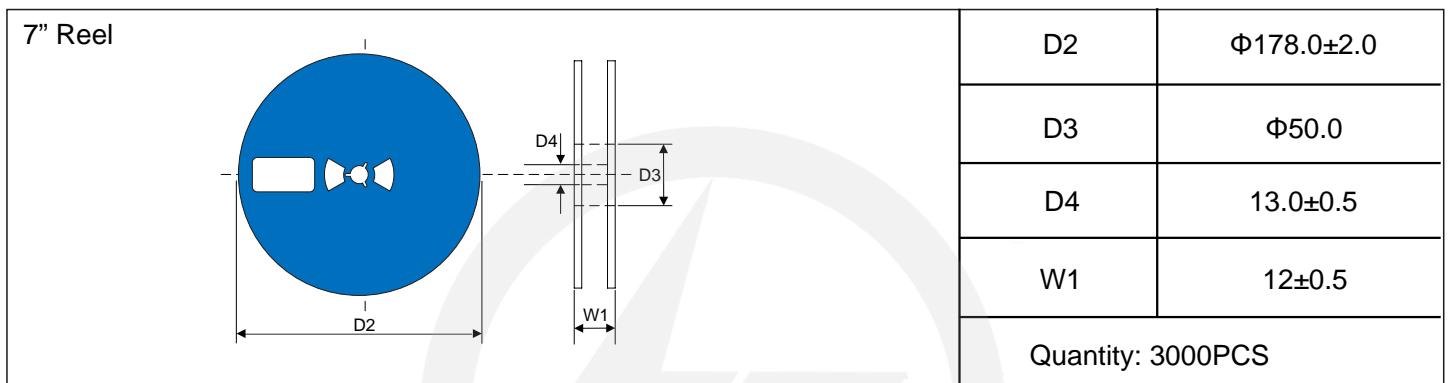

Reel Dimensions

Unit : mm

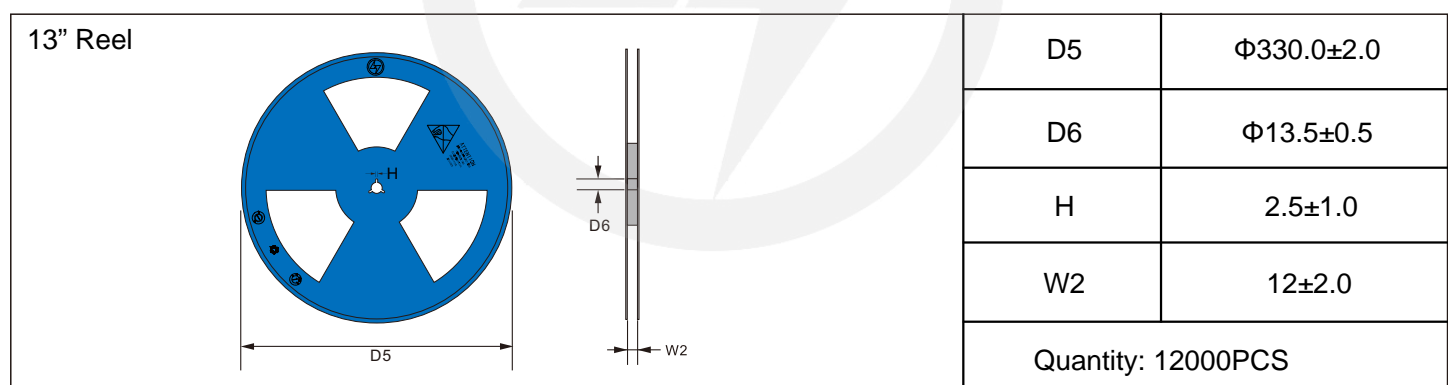

Packaging

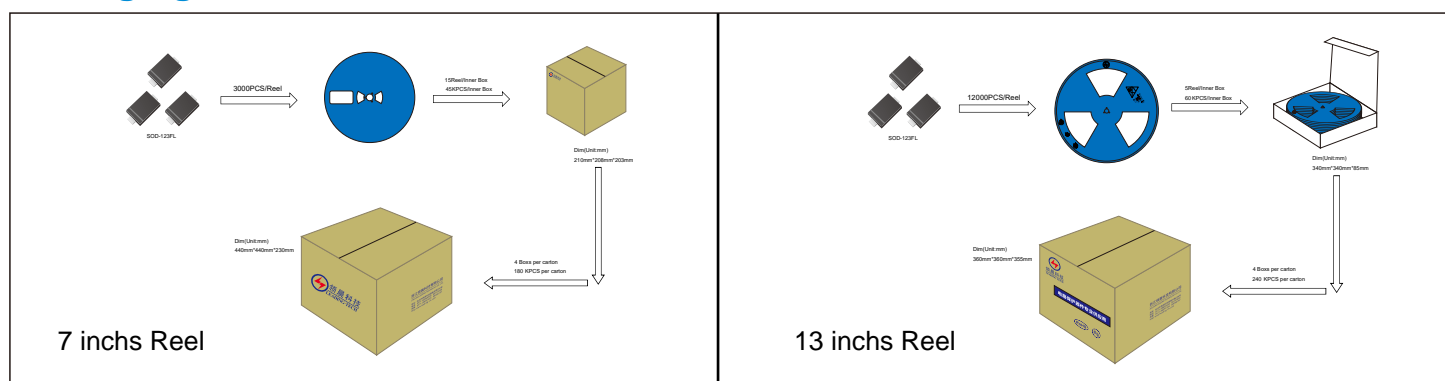



Recommended Soldering Conditions



Recommended Conditions

| Profile Feature | Pb-Free Assembly |
|--|------------------|
| Average ramp-up rate (T _L to T _P) | 3°C/second max. |
| Preheat | |
| -Temperature Min (T _{S min}) | 150°C |
| -Temperature Max (T _{S max}) | 200°C |
| -Time (min to max) (t _s) | 60-180 seconds |
| T _{S max} to T _L | |
| -Ramp-up Rate | 3°C/second max. |
| Time maintained above: | |
| -Temperature (T _L) | 217°C |
| -Time (t _L) | 60-150 seconds |
| Peak Temperature (T _P) | 260°C |
| Time within 5°C of actual Peak Temperature (t _p) | 20-40 seconds |
| Ramp-down Rate | 6°C/second max. |
| Time 25°C to Peak Temperature | 8 minutes max. |

Important Notice and Disclaimer

Leading-Tech reserves the right to make changes to this document and its products and specifications at any time without notice.

Customers should obtain and confirm the latest product information and specifications before final design, purchase or use.

Leading-Tech makes no warranty, representation or guarantee regarding the suitability of its products for any particular purpose, not does Leading-Tech assume any liability for application assistance or customer product design.

Leading-tech does not warrant or accept any liability with products which are purchase or used for any unintended or unauthorized application.

No license is granted by implication or otherwise under any intellectual property rights of Leading-Tech.

Leading-Tech products are not authorized for use as critical components in life support devices or systems without express written approval of Leading-tech.

Version Update Information

| Series NO. | Enactment/Revision Date | Effective Date | Version | Revision content | Revision Reason | Revision Person | Note |
|------------|-------------------------|----------------|---------|------------------------------|-----------------|-----------------|------|
| 01 | 2024.6.17 | 2024.6.17 | 3.0 | New File | / | Ding | |
| 02 | 2025.06.12 | 2025.06.12 | 3.1 | Update packaging information | / | Ding | |