

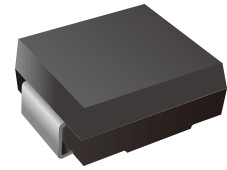

## Thyristor Surge Suppressor

### Features

- Excellent capability of absorbing transient surge
- Quick response to surge voltage (nS Level)
- Eliminates overvoltage caused by fast rising transients
- Moisture sensitivity level: level 1
- Non degenerative
- Bi-directional
- Lead free in comply with EU RoHS 2011/65/EU directives



### Mechanical Data

- Case: SMC
- Lead Material: Copper Alloy
- Terminal Finish: 100% Matte-Tin Plated

### Application

- AC Port
- RJ11

### Ordering Information

Part Number	Marking	Shipping	Reel
LTPC2600H-TR3	P26H	3000PCS Tape&Reel	13 inchs

### Environmental Characteristics

Testing Items	Technical Standards
High Temperature Reverse Bias Test	Temperature: 150±3°C, Bias=80%V <sub>DRM</sub> Time: 168H
High Temperature Life Test	Temperature: 150°C Time: 168H
High-low Temperature Cycle Test	Temperature: From -40°C to 150°C Dwell time: 30min, 100 cycles
High Temperature & High Humidity Test	Temperature: 85°C Humidity: 85% Test time: 168H
Pressure Cooker Test	Temperature: 121°C, 2atm. Humidity: 100% Test time: 96H
Resistance of Soldering Heat	Temperature: 260±5°C Time of dip soldering: 10s, 3times

## Part Number and Electrical Parameter

Part Number	$I_{DRM}@V_{DRM}$		$V_S @ I_S$		$V_T @ I_T$		$I_H$		$C_o$		
	$\mu A$	V	V	mA	V	A	mA	mA	pF		
	Max		Max		Max		Min	Max	Min	Typ	Max
LTPC2600H	5	220	300	800	4	2.2	5	50	160	185	220

Absolute maximum ratings measured at  $T_A = 25^\circ C$  RH = 45%-75% (unless otherwise noted).

$V_S$  is measured at 100KV/S

Off-state Capacitance is measured at  $V_{DC}=2V$ ,  $V_{RMS}=1V$ ,  $f=1MHz$

## Electrical Parameters

Symbol	Parameter
$V_{DRM}$	Peak off-state voltage
$I_{DRM}$	Off-state current
$V_S$	Switching voltage
$I_S$	Switching current
$V_T$	On-state voltage
$I_T$	On-state current
$I_H$	Holding current
$C_o$	Off-state capacitance

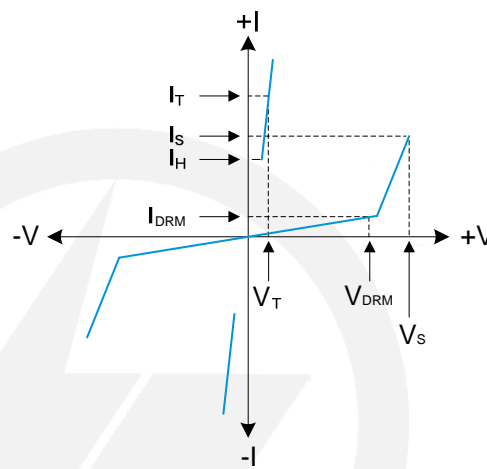

## Surge Ratings

Current Waveform	Voltage Waveform	Ipp
8/20 $\mu s$	1.2/50 $\mu s$	Min : 1500A
di/dt	/	Min : 1500A/ $\mu s$

## Thermal Considerations

Symbol	Parameter	Value	Unit
$T_J$	Operating Junction Temperature Range	-40 to +150	
$T_S$	Storage Temperature Range	-60 to +150	
$R_{\theta JA}$	Thermal Resistance: Junction to Ambient	90	/W

## Product Characteristics

Lead Material	Terminal Finish
Copper Alloy	100% Matte-Tin Plated

**Characteristics Curves**

**Fig.1 Pulse Wavaform**

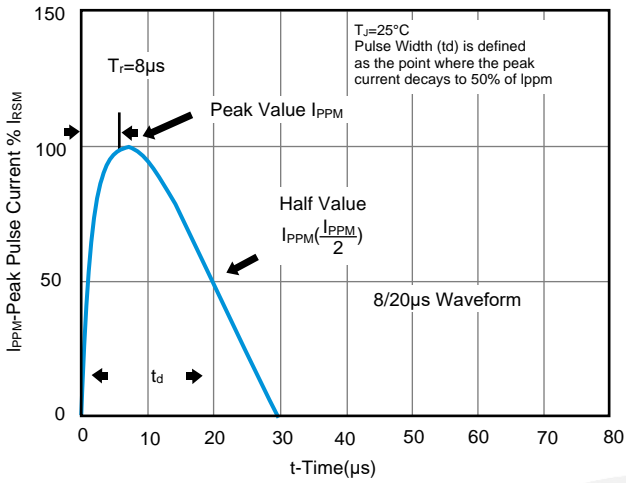

**Fig.2 Repetitive peak off-state current VS Repetitive peak off-state voltage**

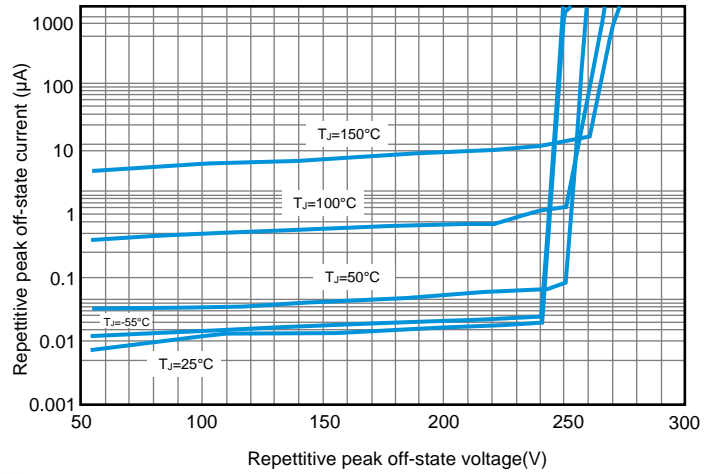

**Fig.3 VS change vs Junction Temperature**

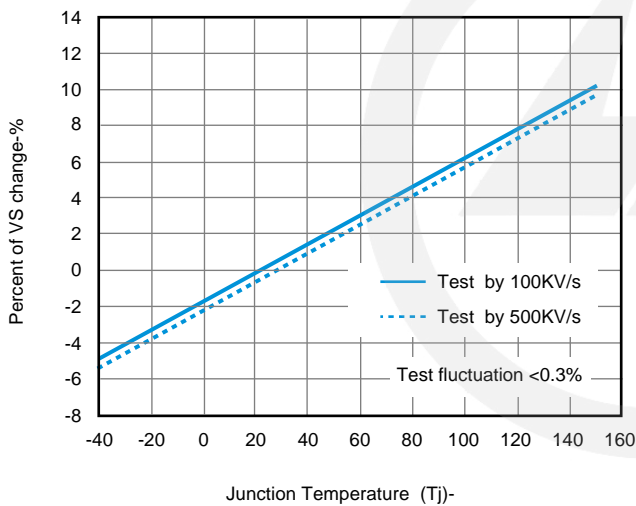

**Fig.4 Capacitance vs Bias voltage**

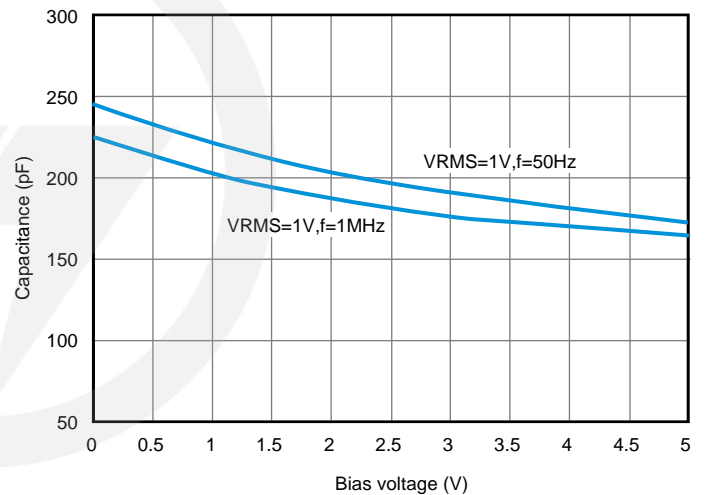

**Fig.5 On-state Voltage vs Junction Temperature**

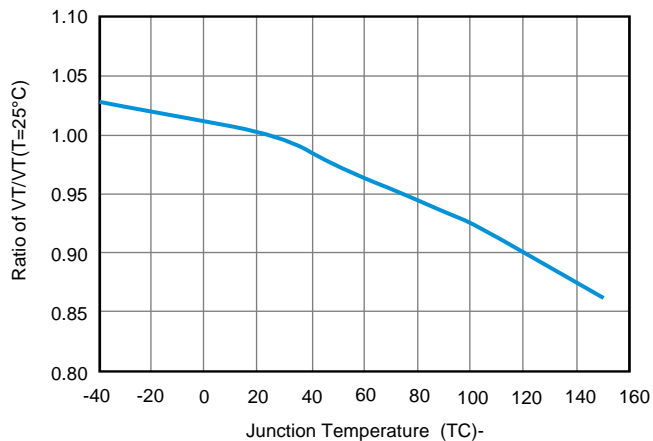

**Fig.6 Holding current vs Junction Temperature**

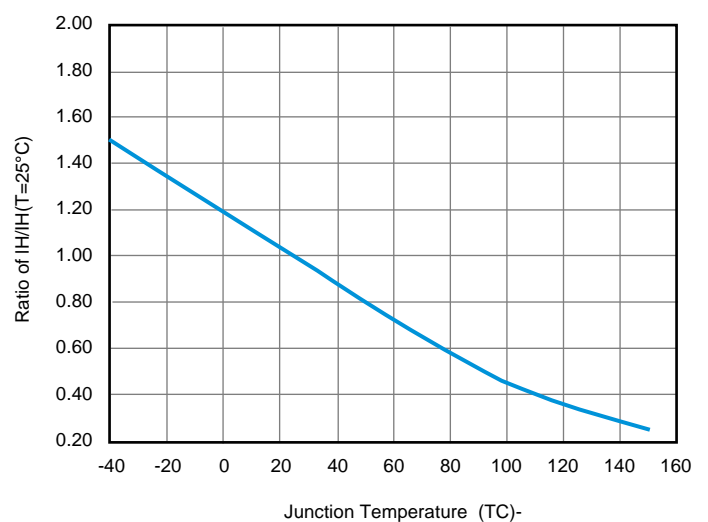

**SMC Package Outline**

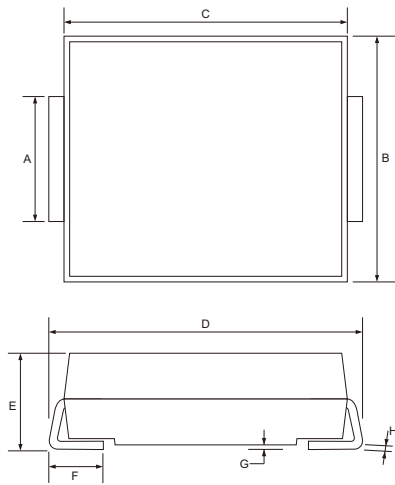

Unit: mm

SYMBOL	DIMENSIONS	
	MIN.	MAX.
A	2.75	3.27
B	5.59	6.22
C	6.50	7.11
D	7.60	8.13
E	1.99	2.80
F	0.76	1.60
G	0.05	0.31
H	0.10	0.31

**SMC Suggested Pad Layout**

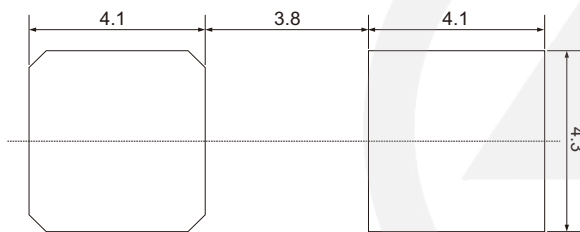

Note:

1. Controlling dimension: in millimeters.
2. General tolerance:  $\pm 0.05\text{mm}$
3. The pad layout is for reference purpose only.

## Carrier Tape Dimensions

Unit : mm

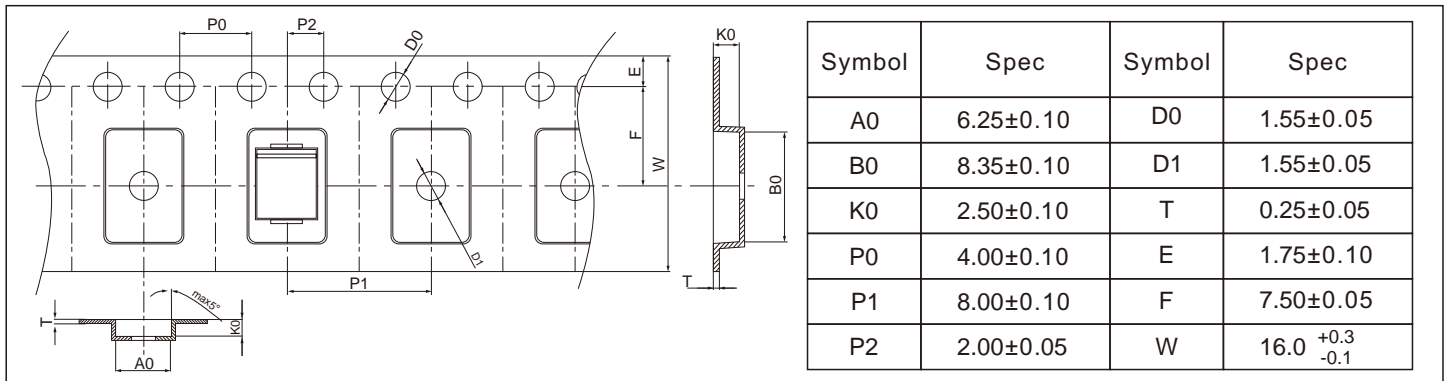

## Reel Dimensions

Unit : mm

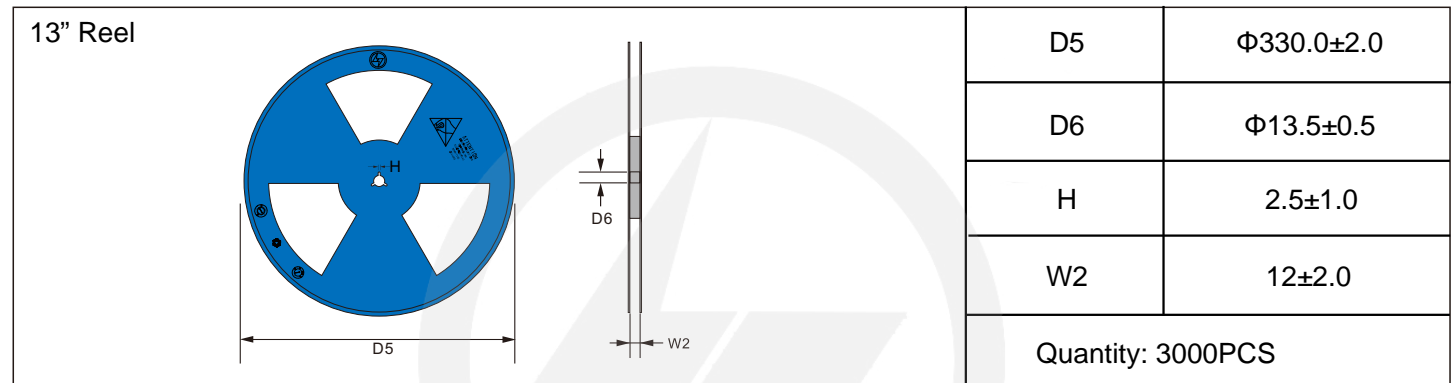

## Packaging

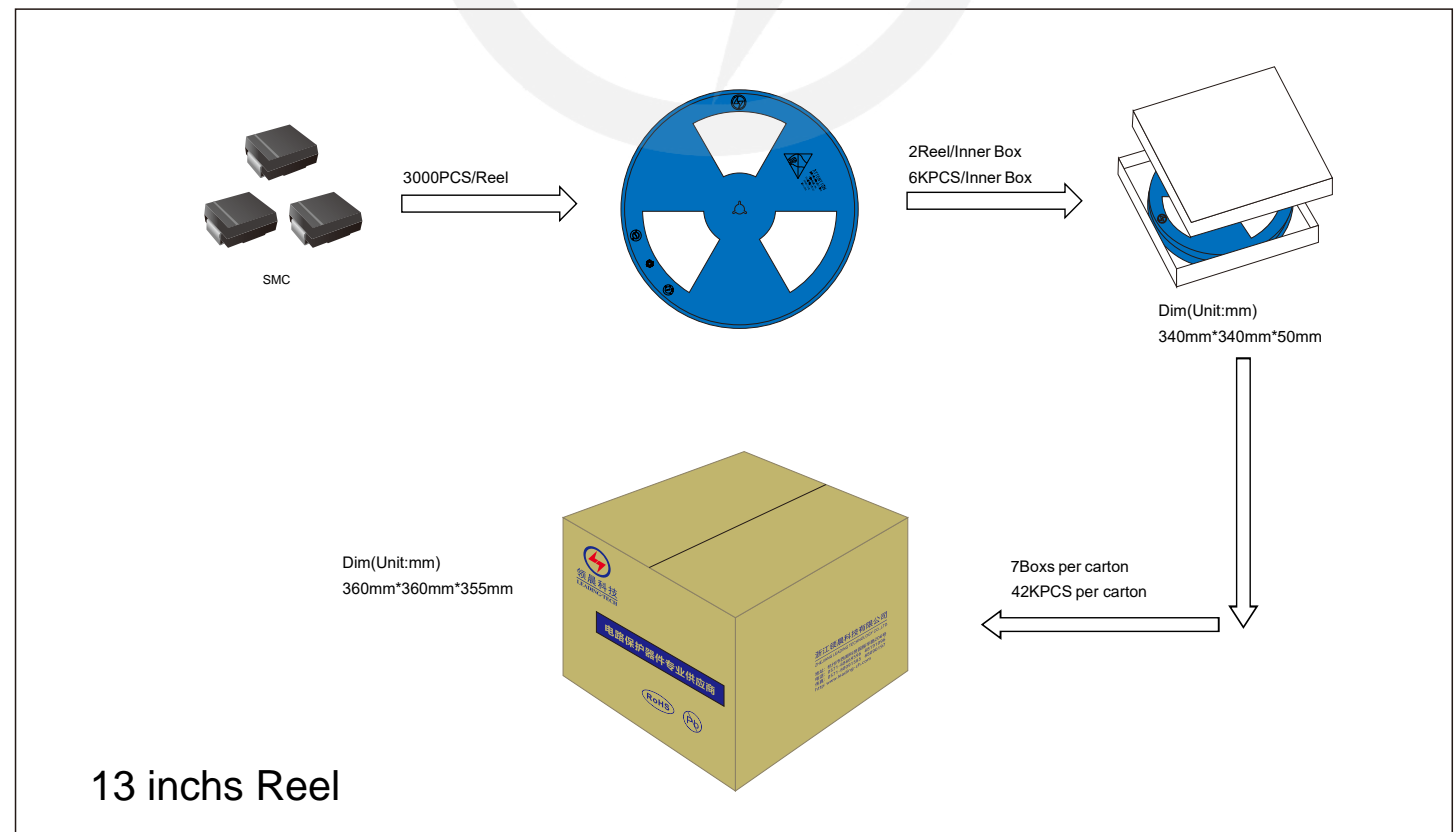



Recommended Soldering Conditions

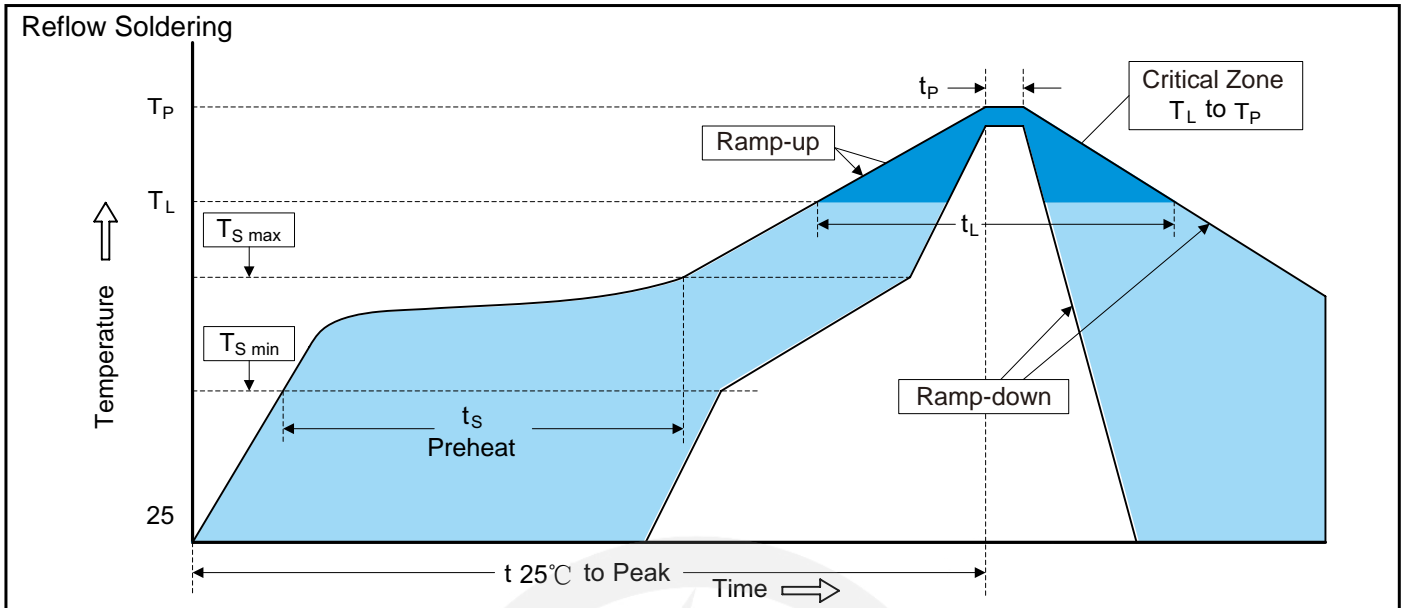

Recommended Conditions

Profile Feature	Pb-Free Assembly
Average ramp-up rate (T <sub>L</sub> to T <sub>P</sub> )	3°C/second max.
Preheat	
-Temperature Min (T <sub>S min</sub> )	150°C
-Temperature Max (T <sub>S max</sub> )	200°C
-Time (min to max) (t <sub>s</sub> )	60-180 seconds
T <sub>S max</sub> to T <sub>L</sub>	
-Ramp-up Rate	3°C/second max.
Time maintained above:	
-Temperature (T <sub>L</sub> )	217°C
-Time (t <sub>L</sub> )	60-150 seconds
Peak Temperature (T <sub>P</sub> )	260°C
Time within 5°C of actual Peak Temperature (t <sub>p</sub> )	20-40 seconds
Ramp-down Rate	6°C/second max.
Time 25°C to Peak Temperature	8 minutes max.

## Important Notice and Disclaimer

Leading-Tech reserves the right to make changes to this document and its products and specifications at any time without notice.

Customers should obtain and confirm the latest product information and specifications before final design, purchase or use.

Leading-Tech makes no warranty, representation or guarantee regarding the suitability of its products for any particular purpose, not does Leading-Tech assume any liability for application assistance or customer product design.

Leading-Tech does not warrant or accept any liability with products which are purchase or used for any unintended or unauthorized application.

No license is granted by implication or otherwise under any intellectual property rights of Leading-Tech.

Leading-Tech products are not authorized for use as critical components in life support devices or systems without express written approval of Leading-tech.

## Version Update Information

Series NO.	Enactment/Revision Date	Effective Date	Version	Revision content	Revision Reason	Revision Person	Note
01	2025.03.15	2025.03.15	3.0	New File	/	Ding	