

## Thyristor Surge Suppressors (TSS) Data Sheet

### Features

- Excellent capability of absorbing transient surge
- Quick response to surge voltage (nS Level)
- Eliminates overvoltage caused by fast rising transients
- Moisture sensitivity level: level 1
- Weight: 100mg
- Non degenerative
- Bi-directional
- Lead free in comply with EU RoHS 2011/65/EU directives

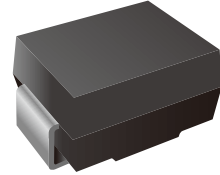

### Application

- AC PORT
- RJ11

### Ordering Information

Part Number	Marking	Shipping	Reel
LTPB2300D-TR3	P23D	3000PCS Tape&Reel	13 inches

### Part Number and Electrical Parameter

Part Number	I <sub>DRM</sub> @V <sub>DRM</sub>		V <sub>S</sub> <sup>①</sup> @I <sub>S</sub>		V <sub>T</sub> @I <sub>T</sub>		I <sub>H</sub>		Co <sup>②</sup>
	μA	V	V	mA	V	A	mA	mA	pF
	Max		Max		Max		Min	Max	Max
LTPB2300D	5	190	260	800	4	2.2	5	150	70

Absolute maximum ratings measured at T<sub>A</sub>= 25°C RH = 45%-75% (unless otherwise noted).

① V<sub>S</sub> is measured at 100KV/S

② Off-state Capacitance is measured at V<sub>DC</sub>=2V, V<sub>RMS</sub>=1V, f=1MHz



### V-I Curve

Parameters	Definition
V <sub>DRM</sub>	Peak Off-state Voltage
I <sub>DRM</sub>	Off-state Current
V <sub>S</sub>	Switching Voltage
I <sub>S</sub>	Switching Current
I <sub>H</sub>	Holding Current
V <sub>T</sub>	On-state Voltage
I <sub>T</sub>	On-state Current
C <sub>o</sub>	Off-state Capacitance

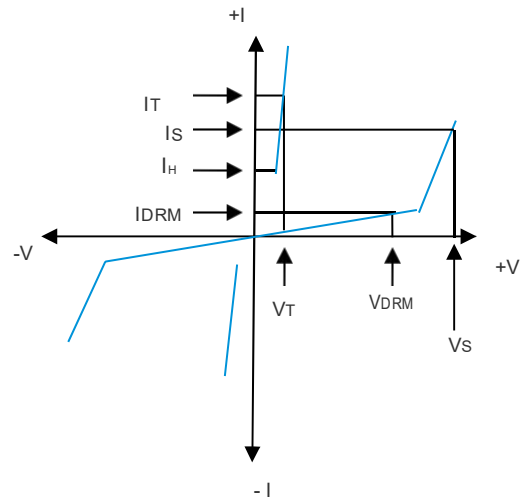

### Surge Ratings

Current Waveform	Voltage Waveform	I <sub>pp</sub>
8/20μs	1.2/50μs	Min: 800A
di/dt	/	Min: 1000A/μs

### Thermal Considerations

Symbol	Parameter	Value	Unit
T <sub>J</sub>	Operating Junction Temperature Range	-40 to +150	°C
T <sub>s</sub>	Storage Temperature Range	-60 to +150	°C

### Physical Characteristics

Lead Material	Copper Alloy
Terminal Finish	100% Matte-Tin Plated



### Characteristics Curves

Fig.1 Normalized holding current VS Junction Temperature

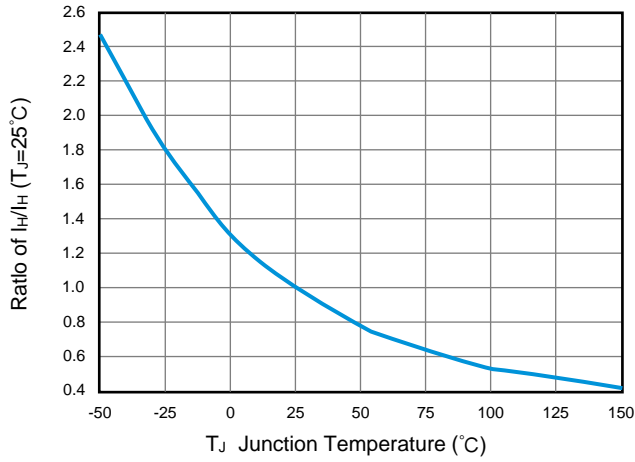

Fig.2 Off-state current VS Junction Temperature

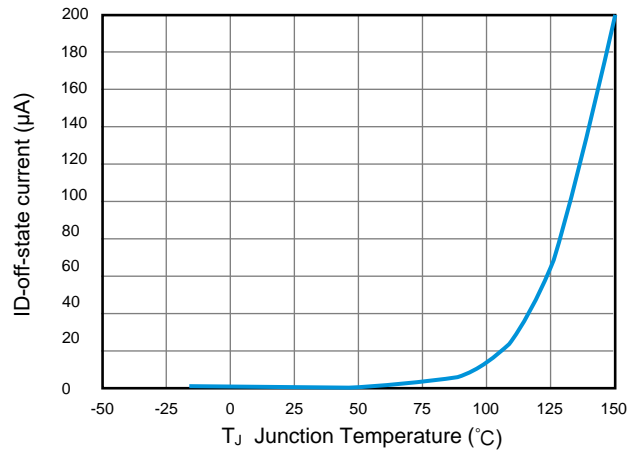

Fig.3 Switching Voltage VS Junction Temperature

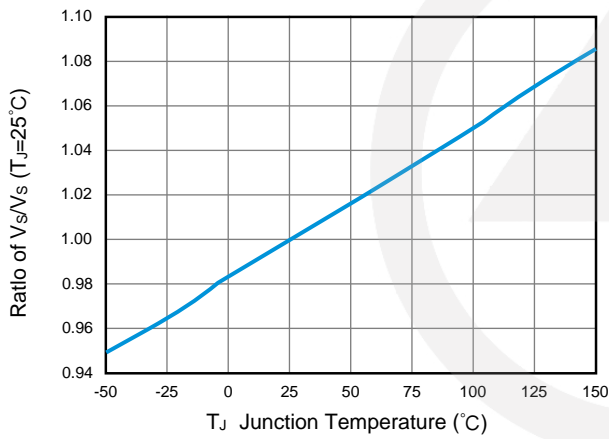

Fig.4 Typical Junction Capacitance( $f=1\text{MHz}$ )

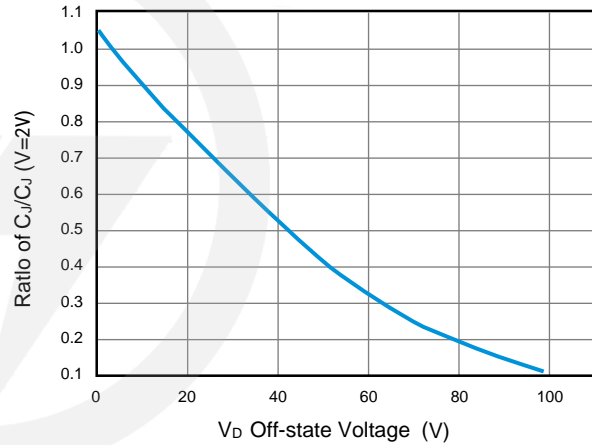
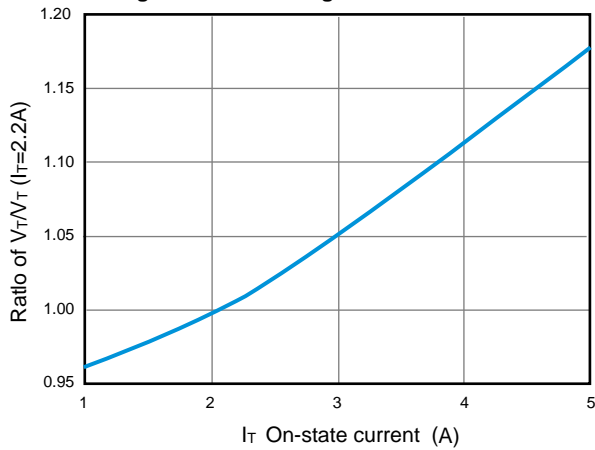
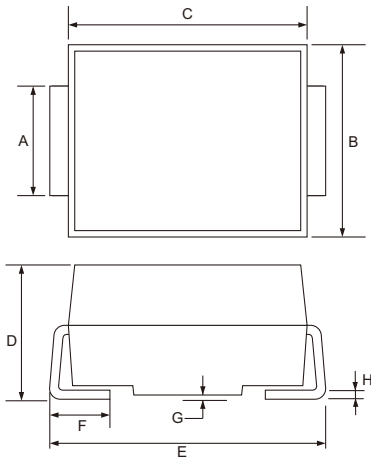

Fig.5 On-state voltage VS On-state current



**SMB Package Outline**



Unit: mm

SYMBOL	DIMENSIONS	
	MIN.	MAX.
A	1.90	2.20
B	3.30	3.94
C	4.05	4.75
D	2.13	2.65
E	5.08	5.59
F	0.76	1.52
G	0.203 TYP.	
H	0.15	0.31

**SMB Suggested Pad Layout**

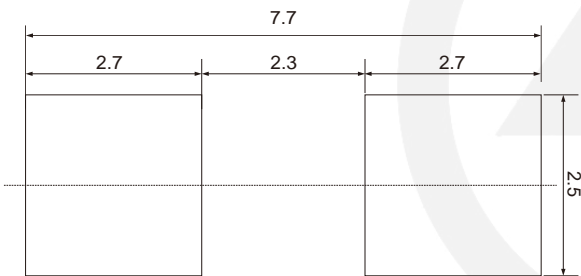

**Note:**

1. Controlling dimension: in millimeters.
2. General tolerance:  $\pm 0.05\text{mm}$
3. The pad layout is for reference purpose only.

**Carrier Tape Dimensions**

Unit : mm

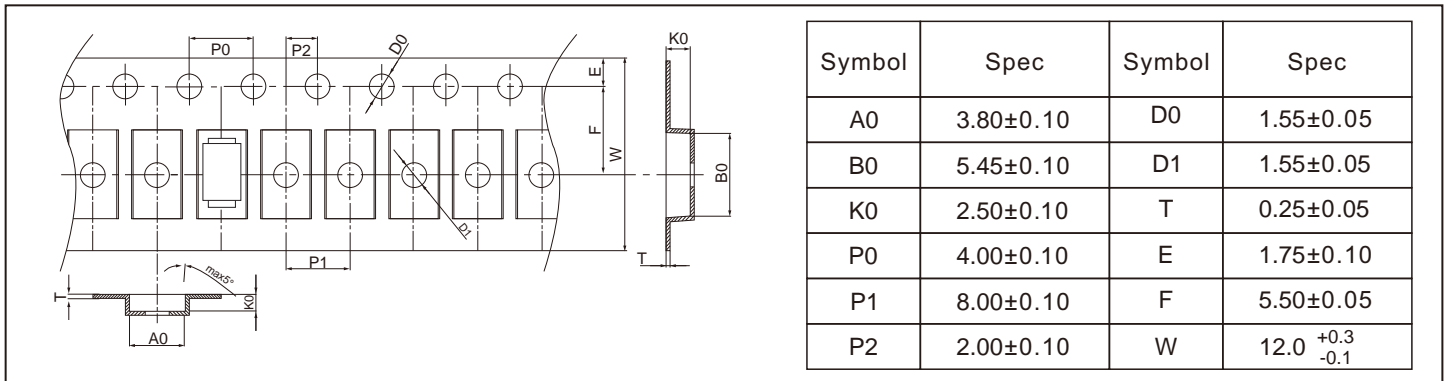

**Reel Dimensions**

Unit : mm

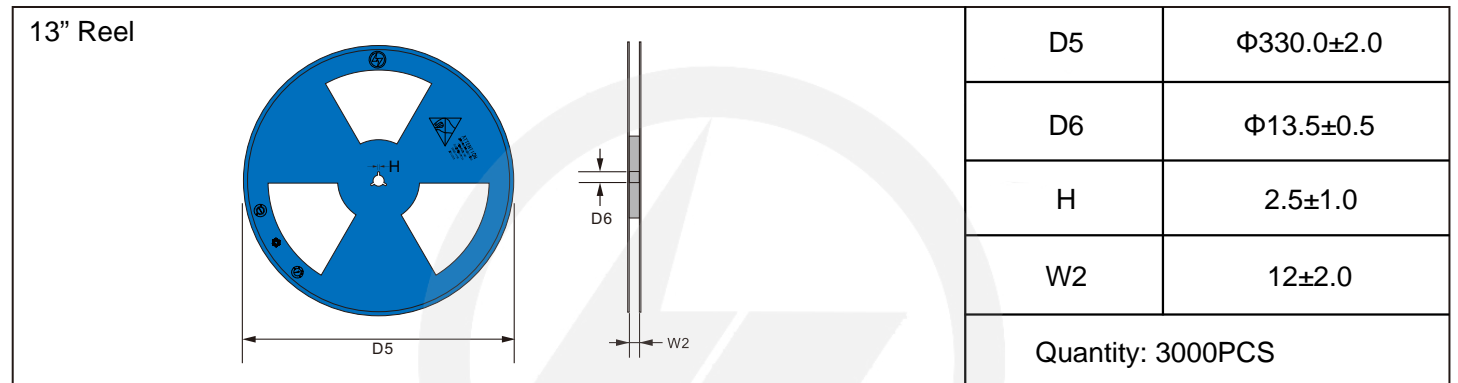

**Packaging**

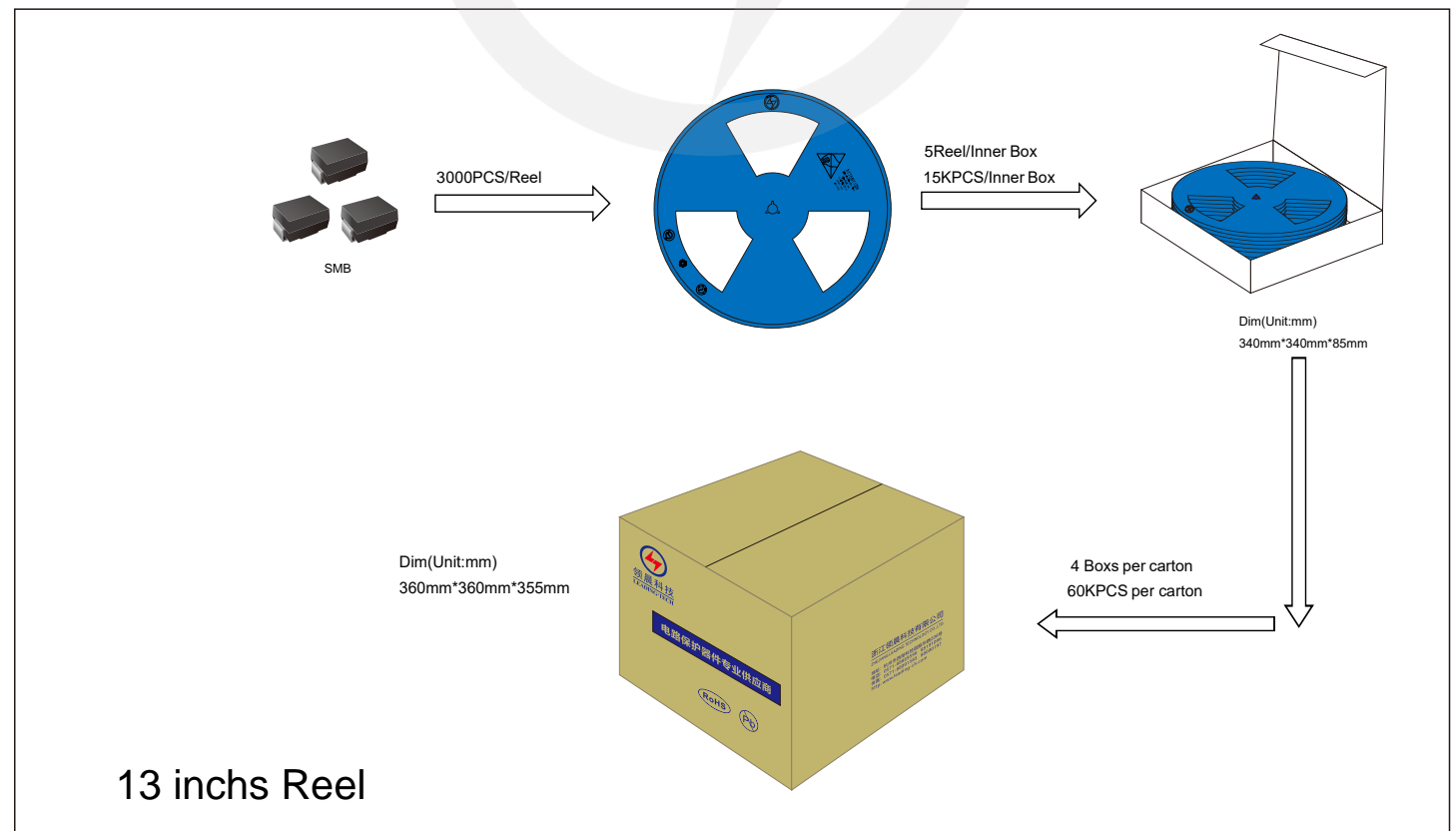



## Recommended Soldering Conditions



### Recommended Conditions

Profile Feature	Pb-Free Assembly
Average ramp-up rate ( $T_L$ to $T_P$ )	3°C/second max.
Preheat	
-Temperature Min ( $T_{S\ min}$ )	150°C
-Temperature Max ( $T_{S\ max}$ )	200°C
-Time (min to max) ( $t_s$ )	60-180 seconds
$T_{S\ max}$ to $T_L$	
-Ramp-up Rate	3°C/second max.
Time maintained above:	
-Temperature ( $T_L$ )	217°C
-Time ( $t_L$ )	60-150 seconds
Peak Temperature ( $T_P$ )	260°C
Time within 5°C of actual Peak Temperature ( $t_p$ )	20-40 seconds
Ramp-down Rate	6°C/second max.
Time 25°C to Peak Temperature	8 minutes max.

## Important Notice and Disclaimer

Leading-Tech reserves the right to make changes to this document and its products and specifications at any time without notice.

Customers should obtain and confirm the latest product information and specifications before final design, purchase or use.

Leading-Tech makes no warranty, representation or guarantee regarding the suitability of its products for any particular purpose, not does Leading-Tech assume any liability for application assistance or customer product design.

Leading-Tech does not warrant or accept any liability with products which are purchase or used for any unintended or unauthorized application.

No license is granted by implication or otherwise under any intellectual property rights of Leading-Tech.

Leading-Tech products are not authorized for use as critical components in life support devices or systems without express written approval of Leading-tech.

## Version Update Information

Series NO.	Enactment/Revision Date	Effective Date	Version	Revision content	Revision Reason	Revision Person	Note
01	2025.02.13	2025.02.13	3.0	New File	/	Ding	
02	2025.08.26	2025.08.26	3.1	Modify Marking	/	Ding	