

Thyristor Surge Suppressors (TSS) Data Sheet

Description

SMB Thyristor solid state protection thyristor protect telecommunications equipment such as modems, line cards, fax machines, and other CPE.

The LTPB065B device is used to enable equipment to meet various regulatory requirements including GR 1089, ITUK.20, K.21 and K.45, IEC 60950, and TIA-968 (formerly known as FCC Part 68).

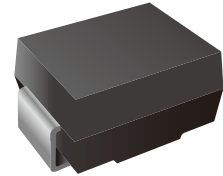

Features

Compared to surge suppression using other technologies, The LTPB065B device offers absolute surge protection regardless of the surge current available and the rate of applied voltage (dv/dt). The LTPB065B device:

- Cannot be damaged by voltage
- Eliminate hysteresis and heat dissipation typically found with clamping devices
- Eliminate voltage overshoot caused by fast-rising transients
- Are non-degenerative
- Will not fatigue
- Have low capacitance, making them ideal for high-speed transmission equipment
- Meets MSL level 1, per J-STD-020
- Lead free in comply with EU RoHS 2011/65/EU directives

Mechanical Data

- Case: SMB
- Approx. Weight: 0.1g

Ordering Information

Part Number	Marking	Shipping	Reel
LTPB065B-TR3	P065B	3000PCS Tape&Reel	13 inches

Thermal Considerations

Parameter	Symbol	Value	Unit
Operating Junction Temperature	T_J	-40 to +150	°C
Storage Temperature Range	T_S	-40 to +150	°C
Junction to Ambient on printed circuit	$R_{\theta JA}$	90	°C/W



Electrical Parameters

Parameter	Definition
V_{DRM}	Peak Off-state Voltage – maximum voltage that can be applied while maintaining off state
V_S	Switching Voltage – maximum voltage prior to switching to on state
V_T	On-state Voltage – maximum voltage measured at rated on-state current
I_{DRM}	Leakage Current – maximum peak off-state current measured at V_{DRM}
I_S	Switching Current – maximum current required to switch to on state
I_T	On-state Current – maximum rated continuous on-state current
I_H	Holding Current – typical current required to maintain on state
C_o	Off-state Capacitance – typical capacitance measured in off state
I_{PP}	Peak Pulse Current – maximum rated peak impulse current
I_{TSM}	Peak One-cycle Surge Current – maximum rated one-cycle AC current
di/dt	Rate of Rise of Current – maximum rated value of the acceptable rate of rise in current over time

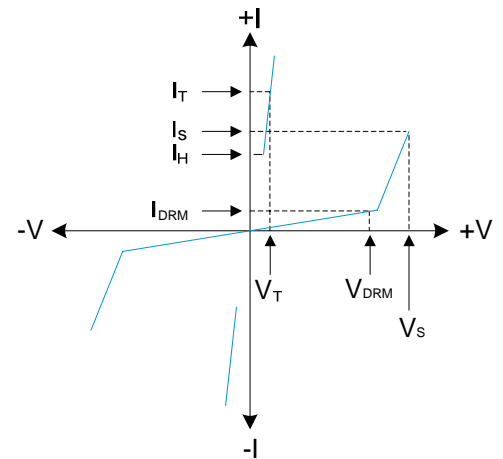

Electrical Characteristics

Part Number	V_{DRM} (V)	V_S (V)	V_T (V)	I_{DRM} (μ A)	I_S (mA)	I_T (A)	I_H (mA)	C_o (pF)		Marking
								Typ.	Max.	
LTPB065B	6	13	4	5	800	2.2	50	65	100	P065B

Notes:

- All measurements are made at an ambient temperature of 25°C. I_{PP} applies to -40°C through +85°C temperature range.
- Off-state capacitance(C_o) is measured at 1 MHz with a 2V bias and is typical value.
- Rating Surge Voltage: 4KV, ± 5 times (10/700 μ s)

Surge Ratings

I_{PP} 2/10 μ s (A)	I_{PP} 8/20 μ s (A)	I_{PP} 10/160 μ s (A)	I_{PP} 10/560 μ s (A)	I_{PP} 10/1000 μ s (A)	I_{TSM} 60Hz (A)	di/dt (A/ μ s)
250	250	150	100	80	30	500

Part Numbering Code

LTP B 065 B
(1) (2) (3) (4)

- (1) Leading TSS
- (2) Package: SMB
- (3) Off-state Voltage:6V
- (4) Rating Surge Voltage:4KV(10/700 us)

Characteristics Curves

Fig.1 tr x td Pulse Wave-form

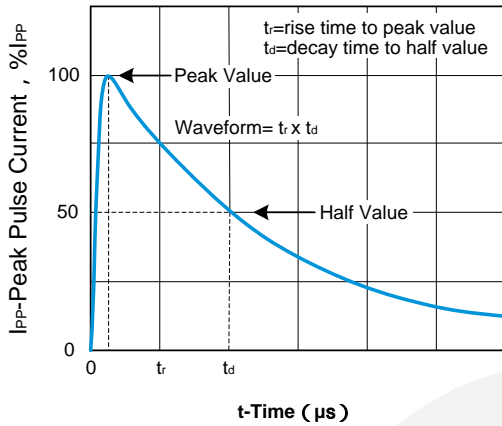

Fig.2 Normalized V_s Change versus Junction Temperature

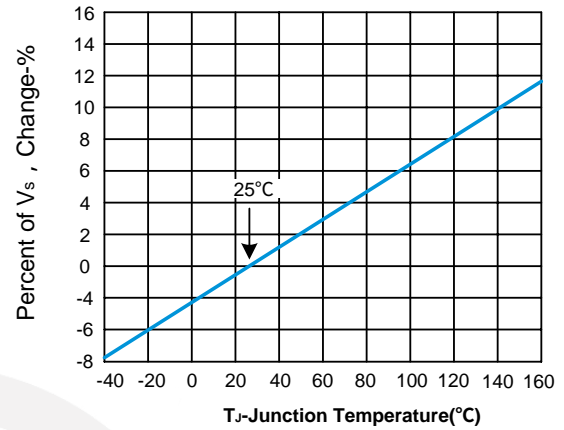
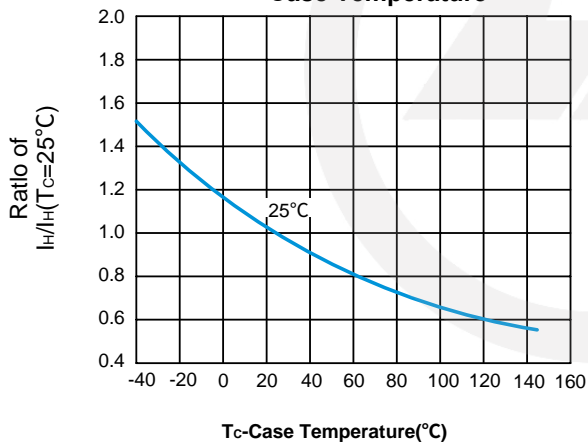
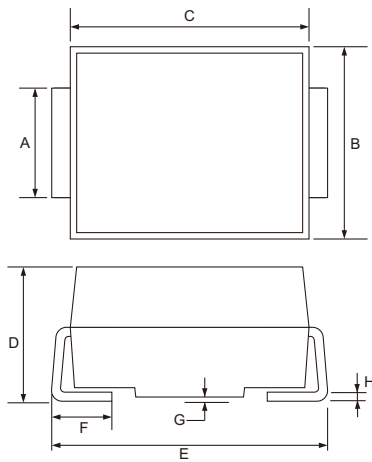

Fig.3 Normalized DC Holding Current versus Case Temperature





SMB Package Outline



Unit: mm

SYMBOL	DIMENSIONS	
	MIN.	MAX.
A	1.90	2.20
B	3.30	3.94
C	4.05	4.75
D	2.13	2.65
E	5.08	5.59
F	0.76	1.52
G	0.203 TYP.	
H	0.15	0.31

SMB Suggested Pad Layout

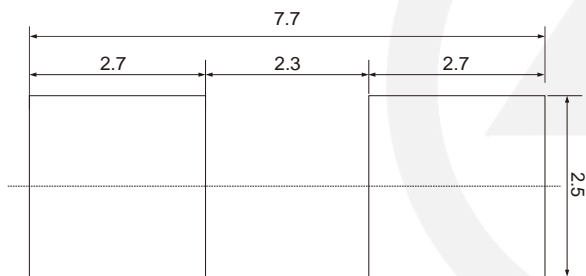

Note:

1. Controlling dimension: in millimeters.
2. General tolerance: $\pm 0.05\text{mm}$
3. The pad layout is for reference purpose only.

Carrier Tape Dimensions

Unit : mm

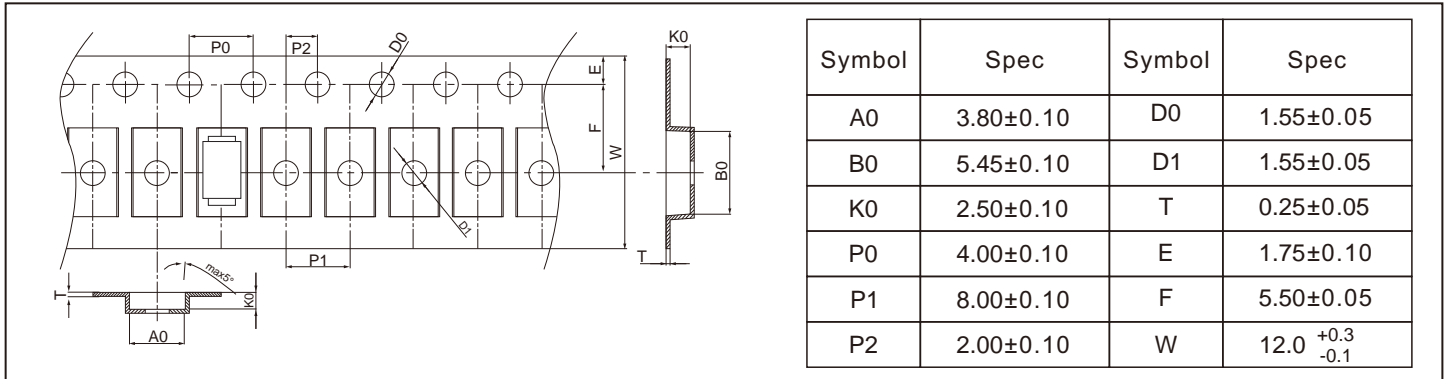

Reel Dimensions

Unit : mm

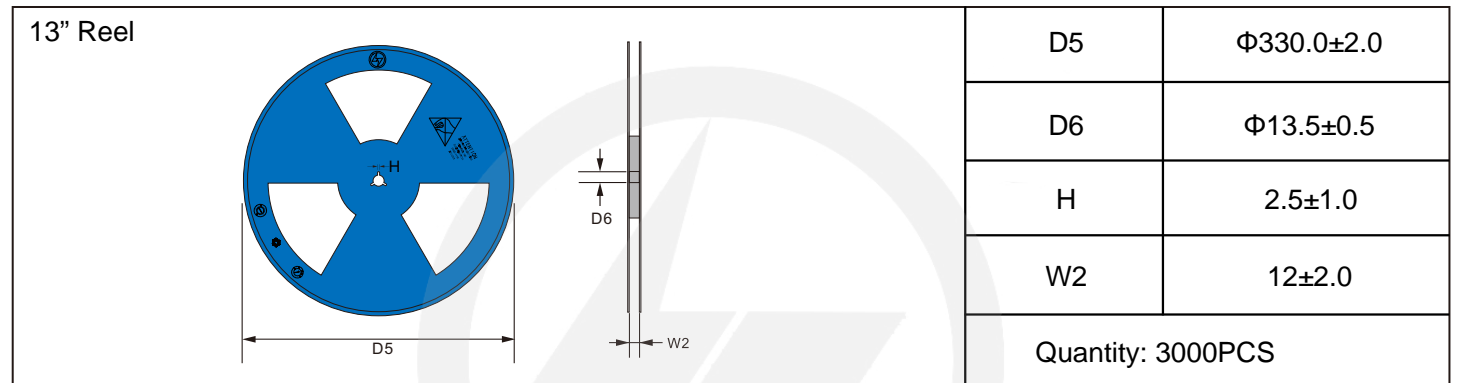

Packaging

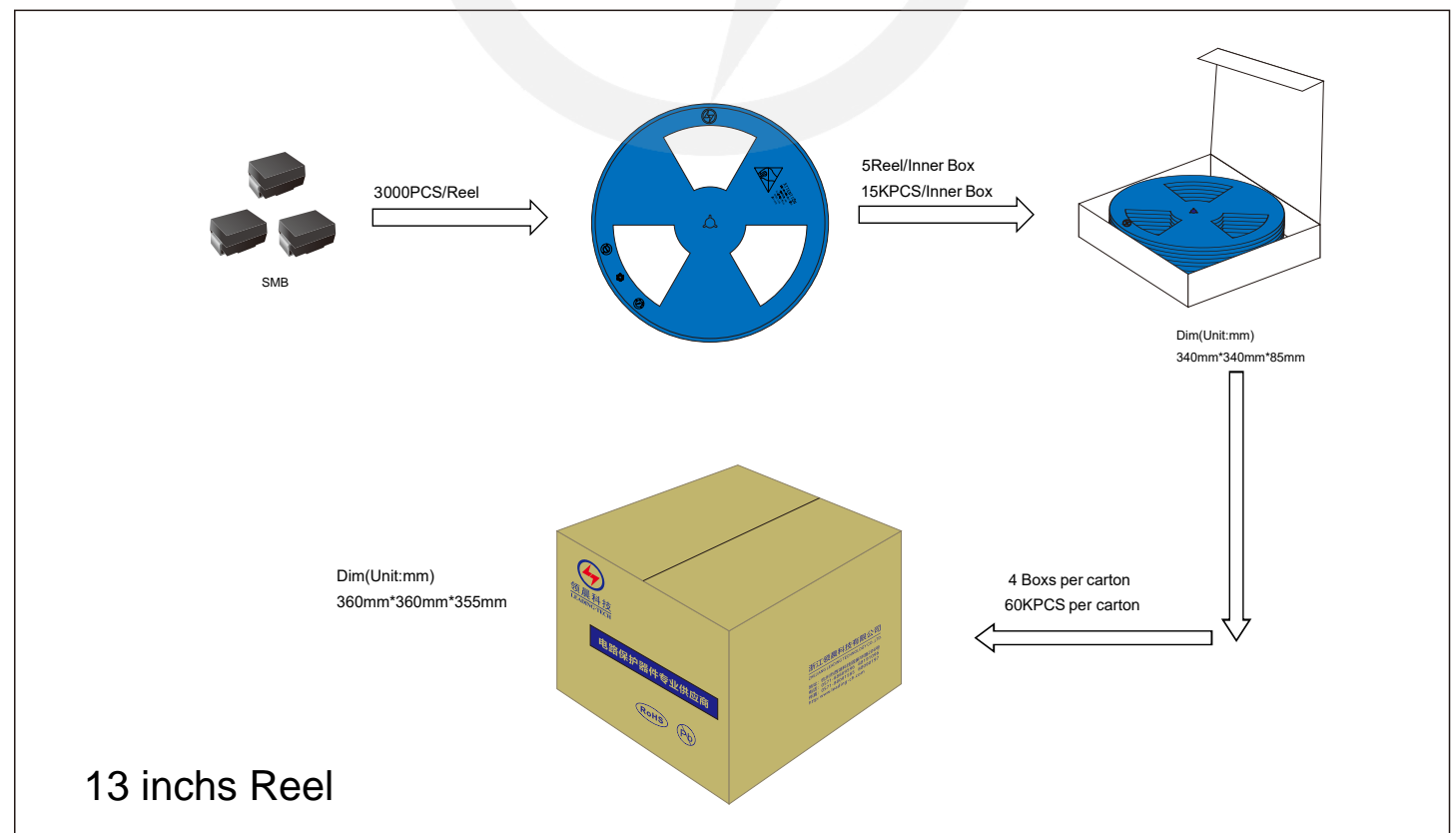



Recommended Soldering Conditions



Recommended Conditions

Profile Feature	Pb-Free Assembly
Average ramp-up rate (T _L to T _P)	3°C/second max.
Preheat	
-Temperature Min (T _{S min})	150°C
-Temperature Max (T _{S max})	200°C
-Time (min to max) (t _s)	60-180 seconds
T _{S max} to T _L	
-Ramp-up Rate	3°C/second max.
Time maintained above:	
-Temperature (T _L)	217°C
-Time (t _L)	60-150 seconds
Peak Temperature (T _P)	260°C
Time within 5°C of actual Peak Temperature (t _p)	20-40 seconds
Ramp-down Rate	6°C/second max.
Time 25°C to Peak Temperature	8 minutes max.

Important Notice and Disclaimer

Leading-Tech reserves the right to make changes to this document and its products and specifications at any time without notice.

Customers should obtain and confirm the latest product information and specifications before final design, purchase or use.

Leading-Tech makes no warranty, representation or guarantee regarding the suitability of its products for any particular purpose, not does Leading-Tech assume any liability for application assistance or customer product design.

Leading-Tech does not warrant or accept any liability with products which are purchase or used for any unintended or unauthorized application.

No license is granted by implication or otherwise under any intellectual property rights of Leading-Tech.

Leading-Tech products are not authorized for use as critical components in life support devices or systems without express written approval of Leading-tech.

Version Update Information

Series NO.	Enactment/Revision Date	Effective Date	Version	Revision Content	Revision Reason	Revision Person	Note
01	2024.5.18	2024.5.18	3.0	New file	/	Ding	
02	2025.06.17	2025.06.17	3.1	Update packaging information	/	Ding	
03	2025.11.12	2025.11.12	3.2	Change the surge rating symbol "x" to "/"	/	Ding	