

Thyristor Surge Suppressors (TSS) Data Sheet

Description

SMB Thyristor solid state protection thyristor protect telecommunications equipment such as modems, line cards, fax machines, and other CPE.

The LTPB012D device is used to enable equipment to meet various regulatory requirements including GR 1089, ITU K.20, K.21 and K.45, IEC 60950, and TIA-968(formerly known as FCC Part 68).

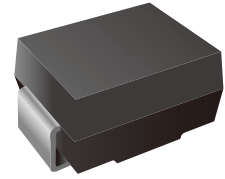

Features

Compared to surge suppression using other technologies, The LTPB012D device offers absolute surge protection regardless of the surge current available and the rate of applied voltage (dv/dt).The LTPB012D device:

- Low profile package
- Low on-state voltage
- Excellent capability of absorbing transient surge
- Quick response to surge voltage (ns Level)
- Eliminates overvoltage caused by fast rising transients
- Moisture sensitivity level: Level 1
- UL 497B item recognized. (File No.: E480698)
- IEC61000-4-2 (ESD) $\pm 30\text{kV}$ (air), $\pm 30\text{kV}$ (contact)
- Non degenerative
- Lead free in comply with EU RoHS 2011/65/EU directives

Ordering Information

Part Number	Marking	Shipping	Reel
LTPB012D-TR3	P12D	3000PCS Tape&Reel	13 inches

Absolute Maximum Ratings ($T_A=25^\circ\text{C}$, RH=45%-75%, unless otherwise noted)

Parameter	Symbol	Value	Unit
Storage temperature range	T_{STG}	-40 to +125	$^\circ\text{C}$
Operating junction temperature range	T_J	-40 to +125	$^\circ\text{C}$
Repetitive peak pulse current@10/1000 μs	I_{PP}	150	A



Electrical Parameters

Symbol	Parameter
V_{DRM}	Peak off-state voltage
I_{DRM}	Off-state current
V_S	Switching voltage
I_S	Switching current
V_T	On-state voltage
I_T	On-state current
I_H	Holding current
C_o	Off-state capacitance

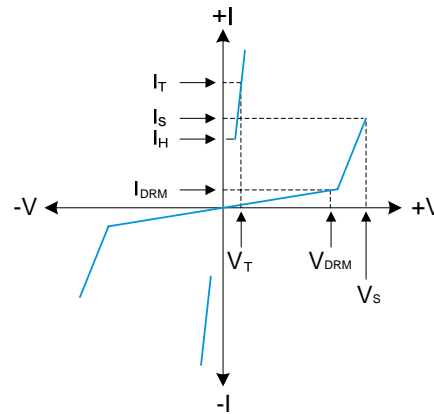

Electrical Characteristics

Part Number	$I_{DRM}@V_{DRM}$		$V_S @I_S$		$V_T@I_T$		I_H	C_o	Marking
	μA	V	V	mA	V	A	mA	pF	
	max		max	max	max	max	min	max	
LTPB012D	1	12	16	800	4	2.2	10	150	P12D

- ① V_S is measured at 100kV/s
- ② Off-state capacitance is measured in $V_{DC}=2V, V_{RMS}=1V, f=1MHz$

Surge Ratings

Series	$I_{PP}(A) \text{ min}$			
	2/10 μs	8/20 μs	10/360 μs	10/1000 μs
D	600	600	200	150

Characteristics Curves

Fig.1 tr x td pulse waveform

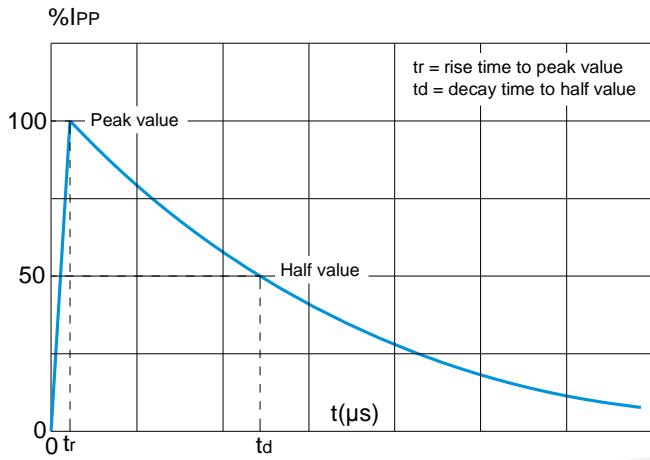

Fig.2 Normalized Vs change vs junction temperature

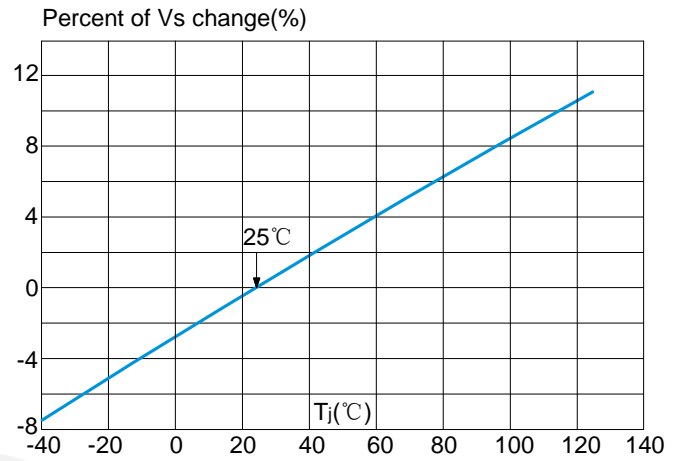
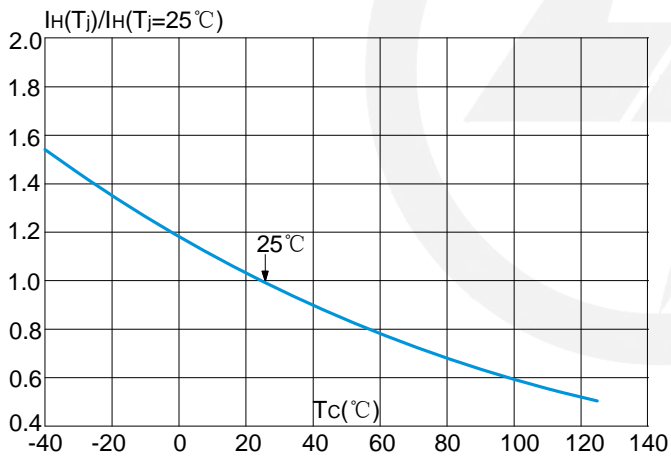
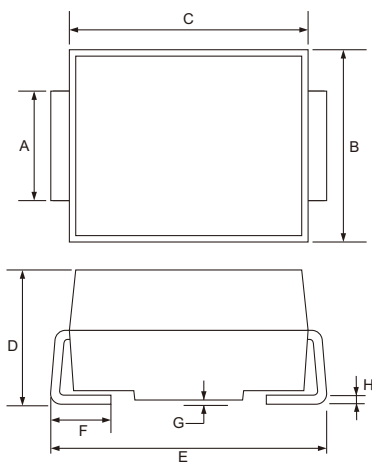

Fig.3 Normalized DC holding current vs case temperature



SMB Package Outline



Unit: mm

SYMBOL	DIMENSIONS	
	MIN.	MAX.
A	1.90	2.20
B	3.30	3.94
C	4.05	4.75
D	2.13	2.65
E	5.08	5.59
F	0.76	1.52
G	0.203 TYP.	
H	0.15	0.31

SMB Suggested Pad Layout

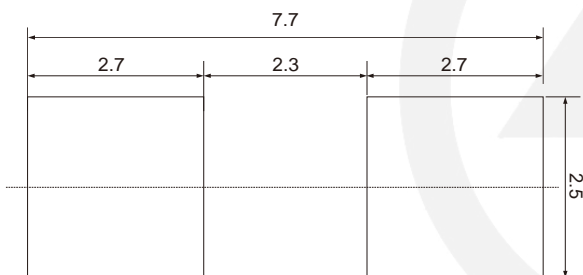

Note:

1. Controlling dimension: in millimeters.
2. General tolerance: $\pm 0.05\text{mm}$
3. The pad layout is for reference purpose only.

Carrier Tape Dimensions

Unit : mm

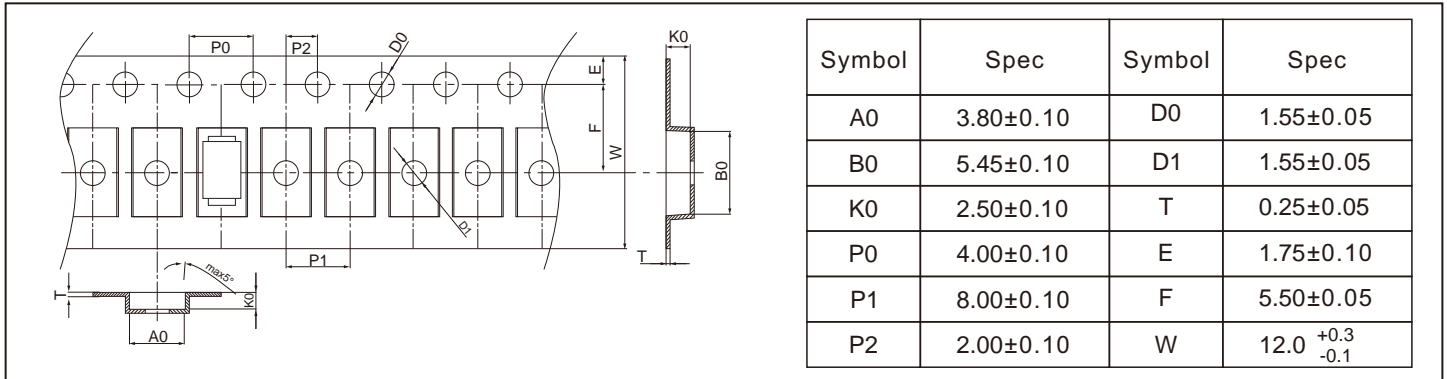

Reel Dimensions

Unit : mm

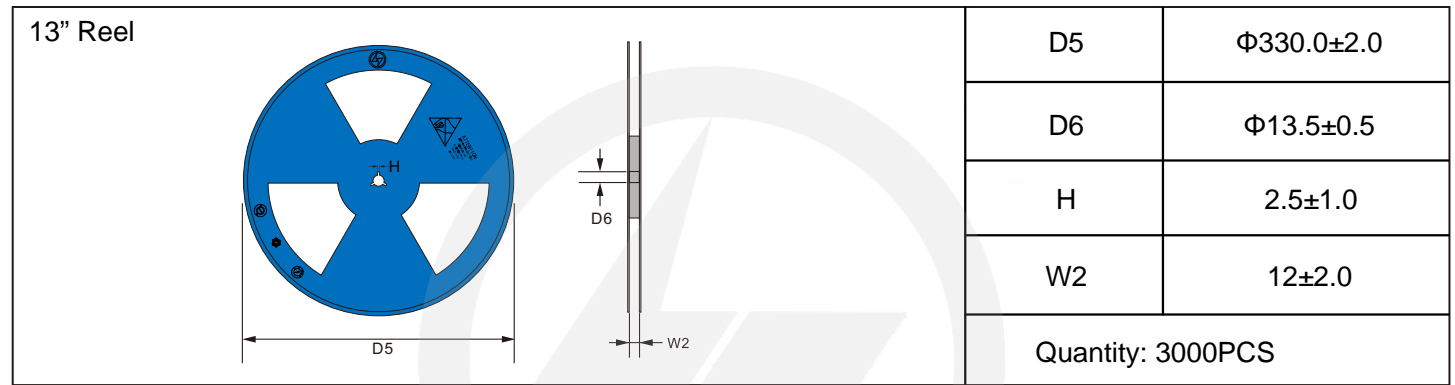

Packaging

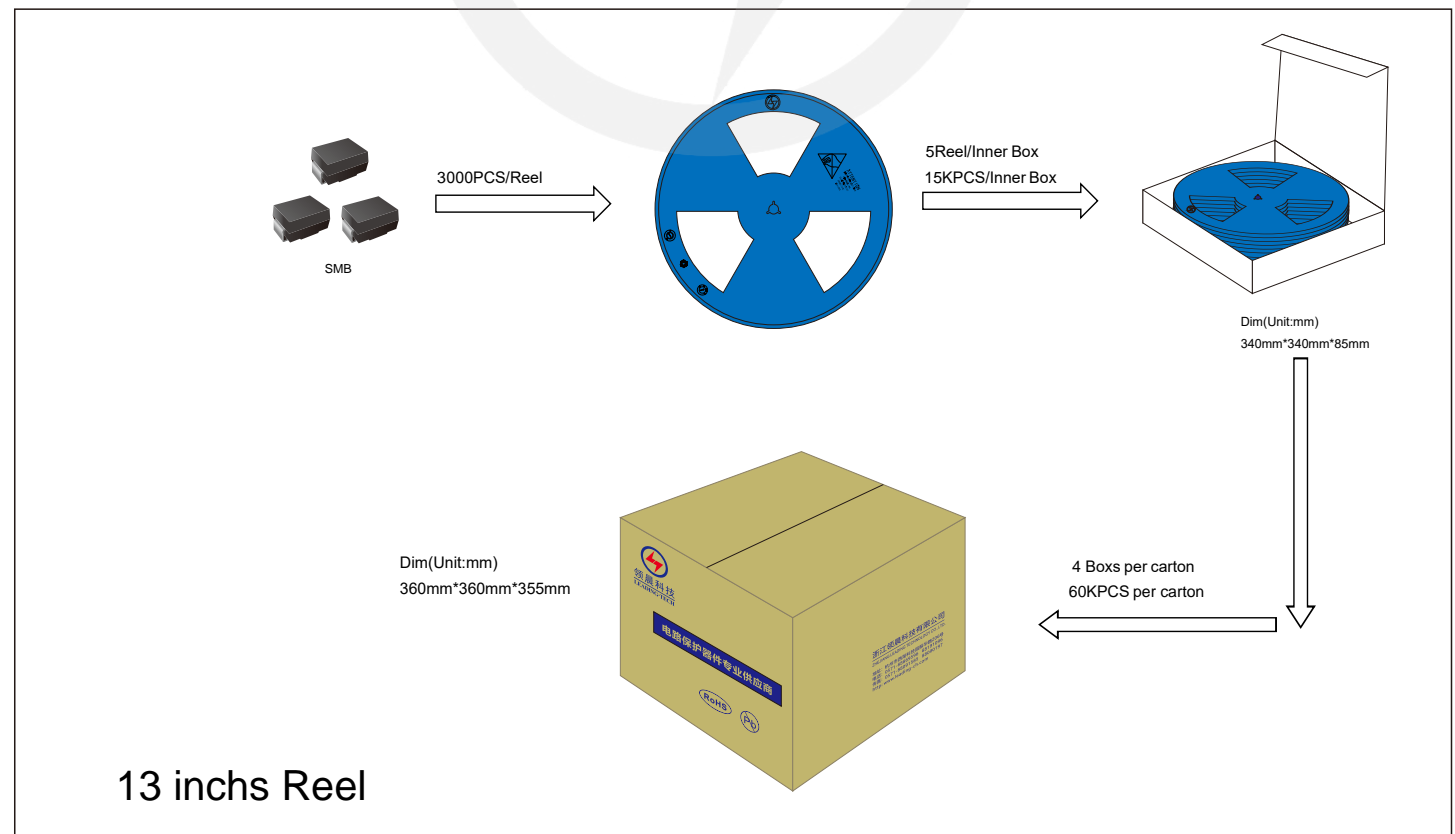



Recommended Soldering Conditions

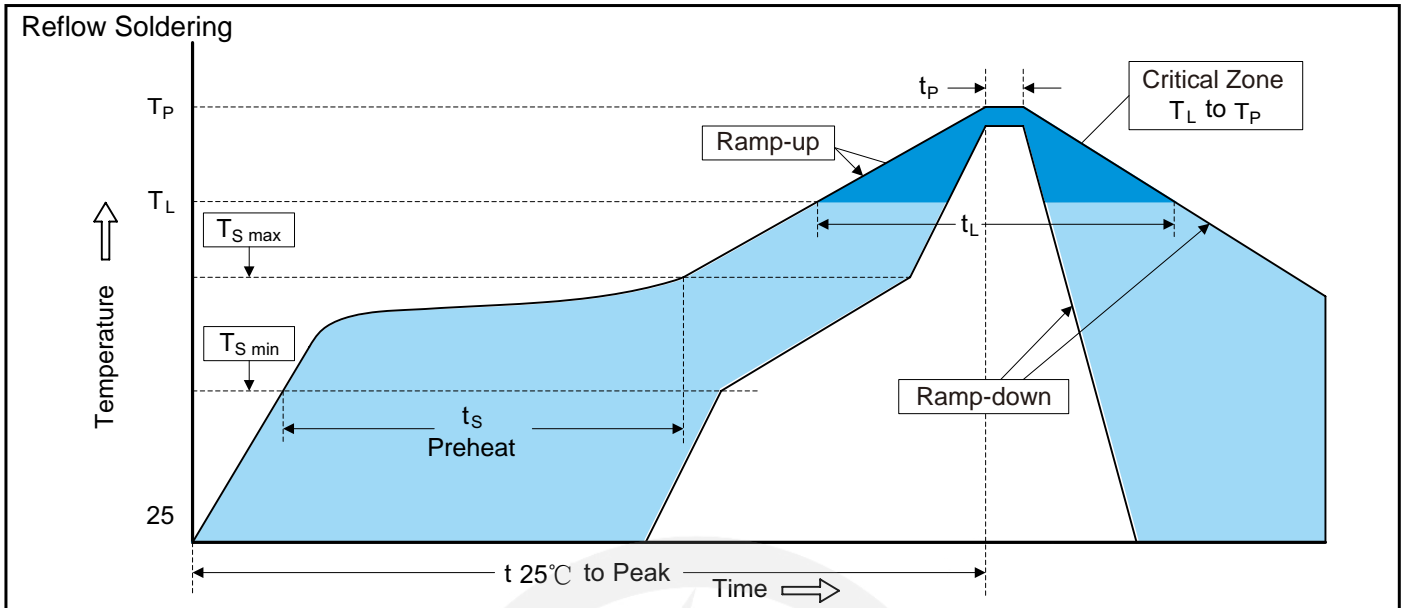

Recommended Conditions

Profile Feature	Pb-Free Assembly
Average ramp-up rate (T _L to T _P)	3°C/second max.
Preheat	
-Temperature Min (T _{S min})	150°C
-Temperature Max (T _{S max})	200°C
-Time (min to max) (t _s)	60-180 seconds
T _{S max} to T _L	
-Ramp-up Rate	3°C/second max.
Time maintained above:	
-Temperature (T _L)	217°C
-Time (t _L)	60-150 seconds
Peak Temperature (T _P)	260°C
Time within 5°C of actual Peak Temperature (t _p)	20-40 seconds
Ramp-down Rate	6°C/second max.
Time 25°C to Peak Temperature	8 minutes max.

Important Notice and Disclaimer

Leading-Tech reserves the right to make changes to this document and its products and specifications at any time without notice.

Customers should obtain and confirm the latest product information and specifications before final design, purchase or use.

Leading-Tech makes no warranty, representation or guarantee regarding the suitability of its products for any particular purpose, not does Leading-Tech assume any liability for application assistance or customer product design.

Leading-tech does not warrant or accept any liability with products which are purchase or used for any unintended or unauthorized application.

No license is granted by implication or otherwise under any intellectual property rights of Leading-Tech.

Leading-Tech products are not authorized for use as critical components in life support devices or systems without express written approval of Leading-tech.

Version Update Information

Series NO.	Enactment/Revision Date	Effective Date	Version	Revision content	Revision Reason	Revision Person	Note
01	2024.12.19	2024.12.19	3.0	New File	/	Ding	