

P-channel Enhancement Mode Power Mosfet

Features

- Advanced Trench Technology
- Excellent $R_{DS(ON)}$ and Low Gate Charge
- Lead free in comply with EU RoHS 2011/65/EU directives

Mechanical Data

- Case: SOT-23
- Approx. Weight: 8.1mg

Application

- PWM Applications
- Load Switch
- Power Management

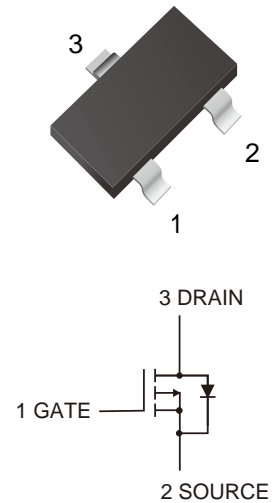

Ordering Information

Part Number	Marking	Shipping	Reel
LTM3H60P-TR3	KJH	3000PCS Tape&Reel	7 inches
LTM3H60P-TR12	KJH	12000PCS Tape&Reel	13 inches

Maximum Ratings ($T_a=25^\circ\text{C}$ unless otherwise noted)

Parameter	Symbol	Value	Unit
Drain-Source Voltage	V_{DSS}	-60	V
Gate-Source Voltage	V_{GSS}	± 20	V
Continuous Drain Current $T_A=25^\circ\text{C}$	I_D	-3	A
Pulsed Drain Current	I_{DM}	-9	A
Power Dissipation	P_D	1.3	W
Thermal Resistance-Junction to Ambient	$R_{\theta JA}$	96.1	$^\circ\text{C/W}$
Operation Junction Temperature	T_j	150	$^\circ\text{C}$
Storage Temperature	T_{stg}	-55 to +150	$^\circ\text{C}$

Electrical Characteristics (Ta=25°C unless otherwise noted)

Parameter	Symbol	Test conditions	Min	Typ	Max	Unit
OFF Characteristics						
Drain-Source Breakdown Voltage	BV _{DSS}	V _{GS} = 0V, I _D = -250uA	-60			V
Drain-Source Leakage Current	I _{DSS}	V _{DS} = -60V, V _{GS} = 0V			-1	uA
Gate- Source Leakage Current	I _{GSS}	V _{GS} = ±20V, V _{DS} = 0V			±100	nA
On Characteristics						
Gate Threshold Voltage	V _{GS(th)}	V _{DS} = V _{GS} , I _D = -250uA	-1		-2.5	V
Static Drain-Source On-State Resistance(Note1)	R _{DS(on)}	V _{GS} = -10V, I _D = -3A		81	102	mΩ
		V _{GS} = -4.5V, I _D = -2A		98	130	
Dynamic Characteristics(Note2)						
Input Capacitance	C _{ISS}	V _{DS} = -30V V _{GS} = 0V f = 1MHz		930		pF
Output Capacitance	C _{OSS}			85		
Reverse Transfer Capacitance	C _{RSS}			35		
Switching Characteristics(Note2)						
Total Gate Charge	Q _g	V _{DS} = -30V V _{GS} = -10V I _D = -3A		25		nC
Gate-Source Charge	Q _{gs}			3		
Gate-Drain Charge	Q _{gd}			7		
Turn-On Delay Time	t _{d(on)}	V _{DS} =-30V, R _{GEN} =3Ω, V _{GS} =-10V, R _L =7.5Ω		8		ns
Turn-On Rise Time	t _{rr}			4		
Turn-Off Delay Time	t _{d(off)}			32		
Turn-Off Fall Time	t _f			7		
Body Diode Characteristics						
Drain-Source Diode Forward Voltage	V _{SD}	I _S = -3A, V _{GS} = 0V			1.2	V
Diode Forward Current(Note1)	I _S				-3	A
Reverse Recovery Charge	t _{rr}	di/dt=100A/μs, T _J =25°C I _F = -3A		25		nS
Reverse Recovery Time	Q _{rr}				31	

Notes:

- 1.Pulse Test: Pulse Width < 300μs, Duty Cycle ≤2%.
- 2.Guaranteed by design, not subject to production testing.



Characteristic Curves

Fig.1 Output characteristics

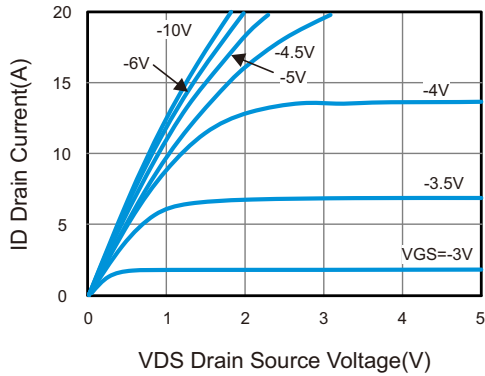

Fig.2 Transfer characteristics

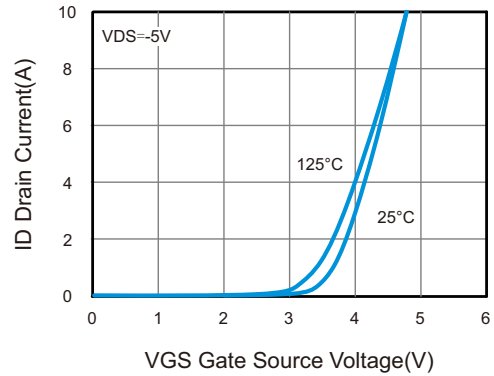

Fig.3 Rds(on) Drain Current

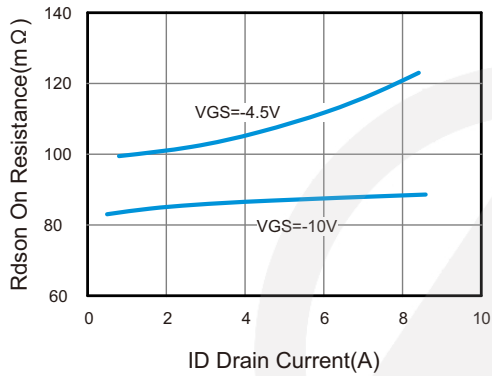

Fig.4 Rds(on) Junction Temperature

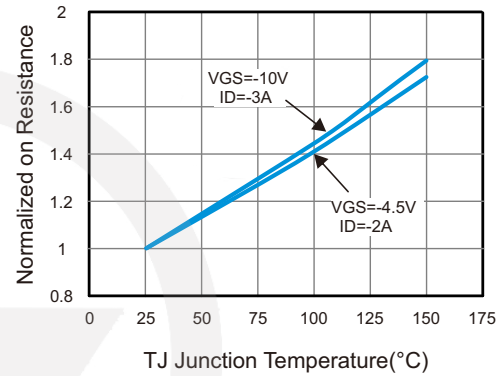

Fig.5 Gate Charge

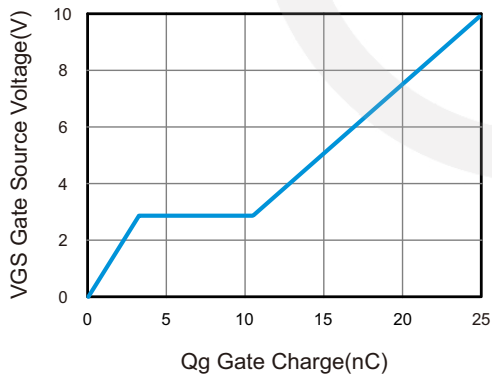

Fig.6 Source Drain Diode Forward

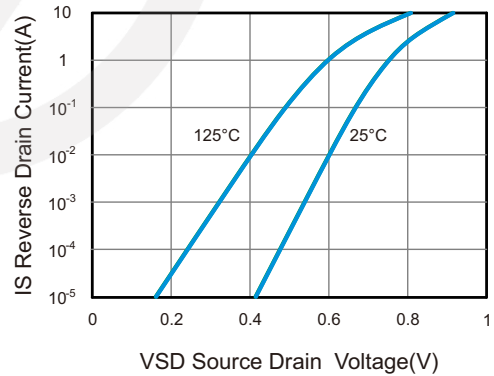

Fig.7 Capacitance vs VDS

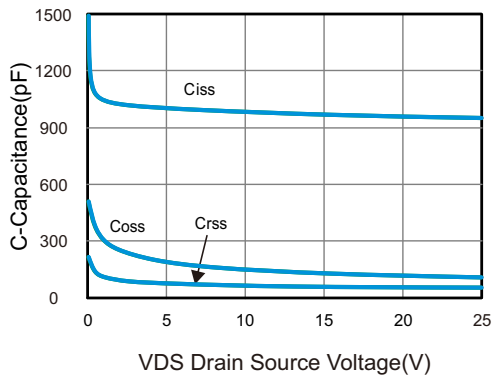

Fig.8 Safe Operation Area

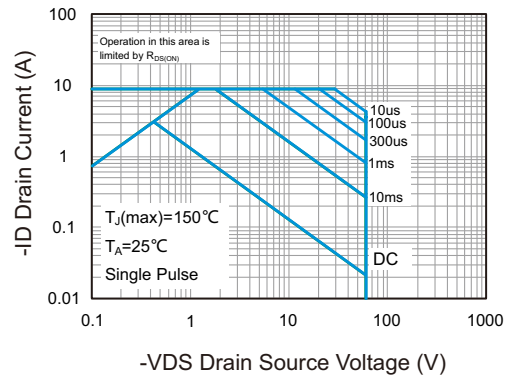



Fig.9 Bv_{ds} vs Junction Temperature

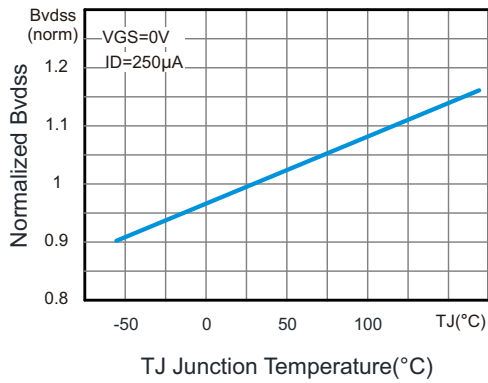

Fig.10 I_D Current De-rating

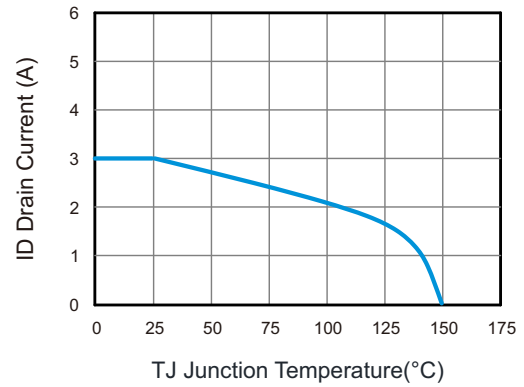
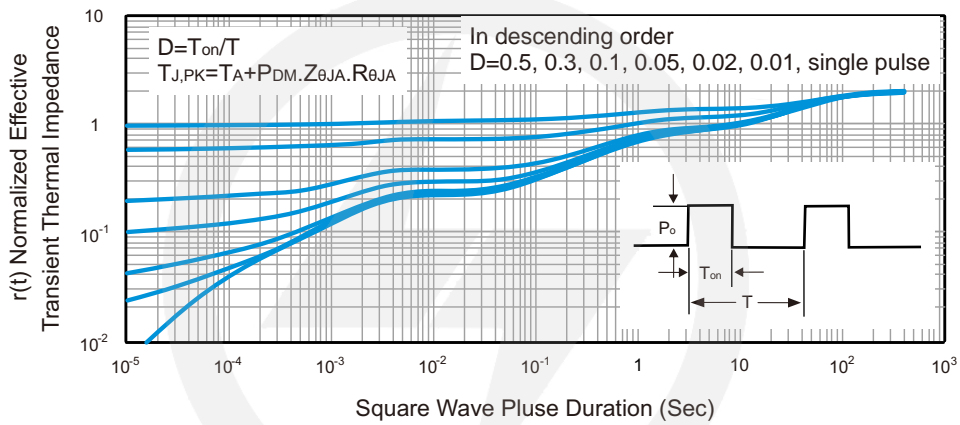
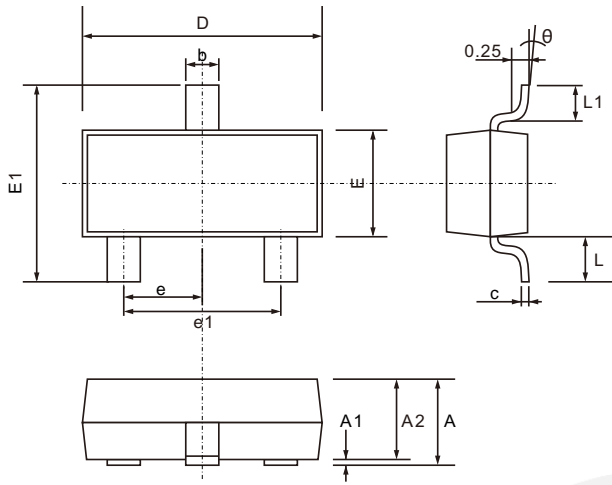

Fig.11 Normalized Maximum Transient Thermal Impedance



SOT-23 Package Outline

Unit: mm



SYMBOL	DIMENSIONS	
	MIN.	MAX.
A	0.900	1.200
A1	0.000	0.100
A2	0.900	1.050
b	0.300	0.500
c	0.080	0.200
D	2.700	3.100
E	1.200	1.400
E1	2.200	2.600
e	0.950 TYP.	
e1	1.750	2.050
L	0.550 TYP.	
L1	0.300	0.500
θ	0°	8°

SOT-23 Suggested Pad Layout

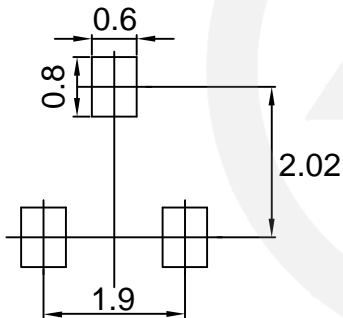

Note:

1. Controlling dimension: in millimeters.
2. General tolerance: $\pm 0.05\text{mm}$
3. The pad layout is for reference purpose only.

Carrier Tape Dimensions

Unit : mm

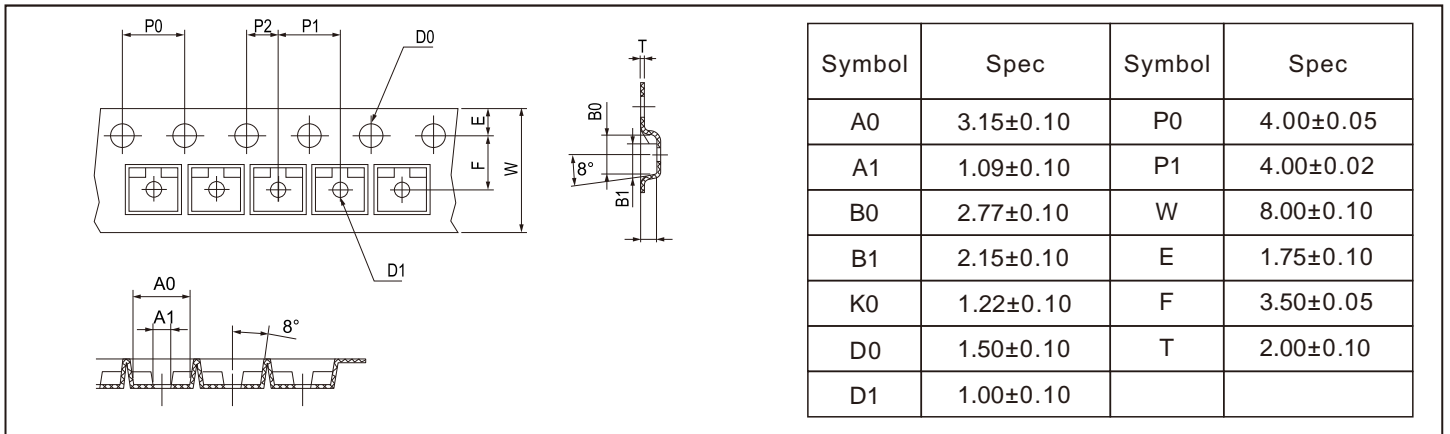

Reel Dimensions

Unit : mm

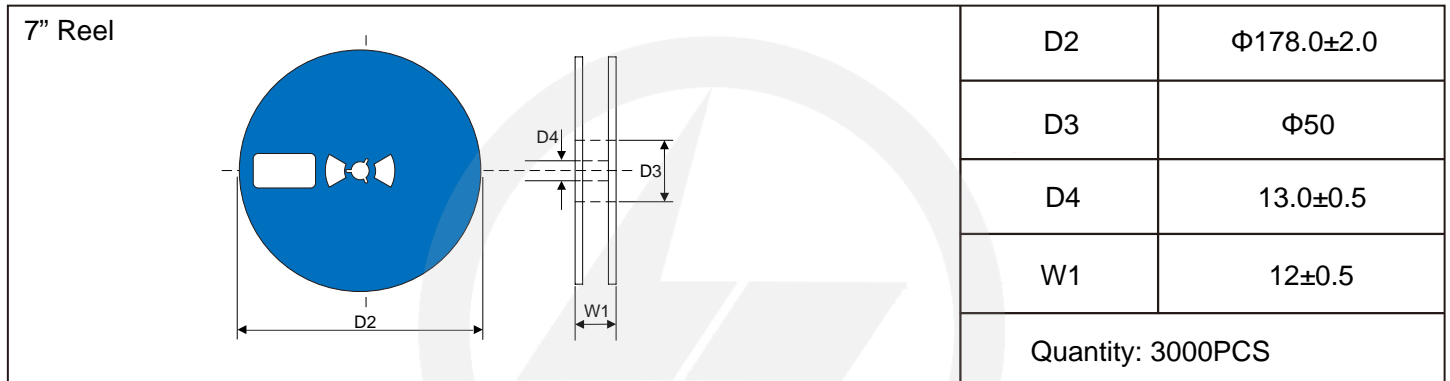

Reel Dimensions

Unit : mm

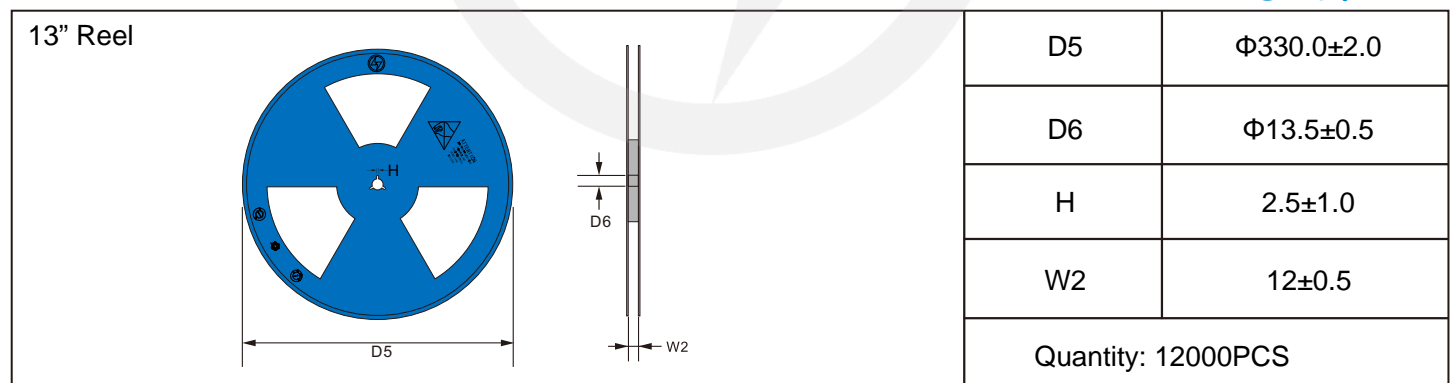

Packaging

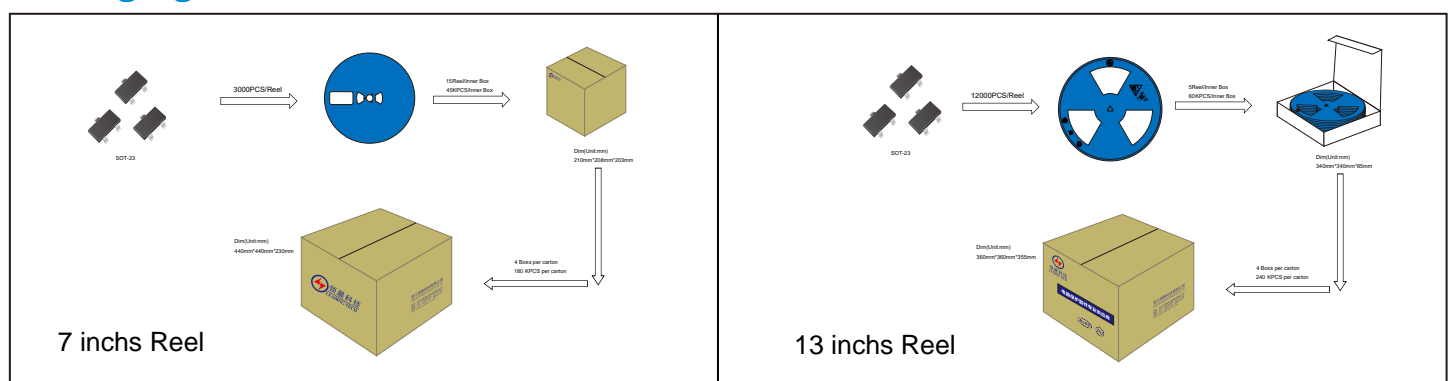



Recommended Soldering Conditions

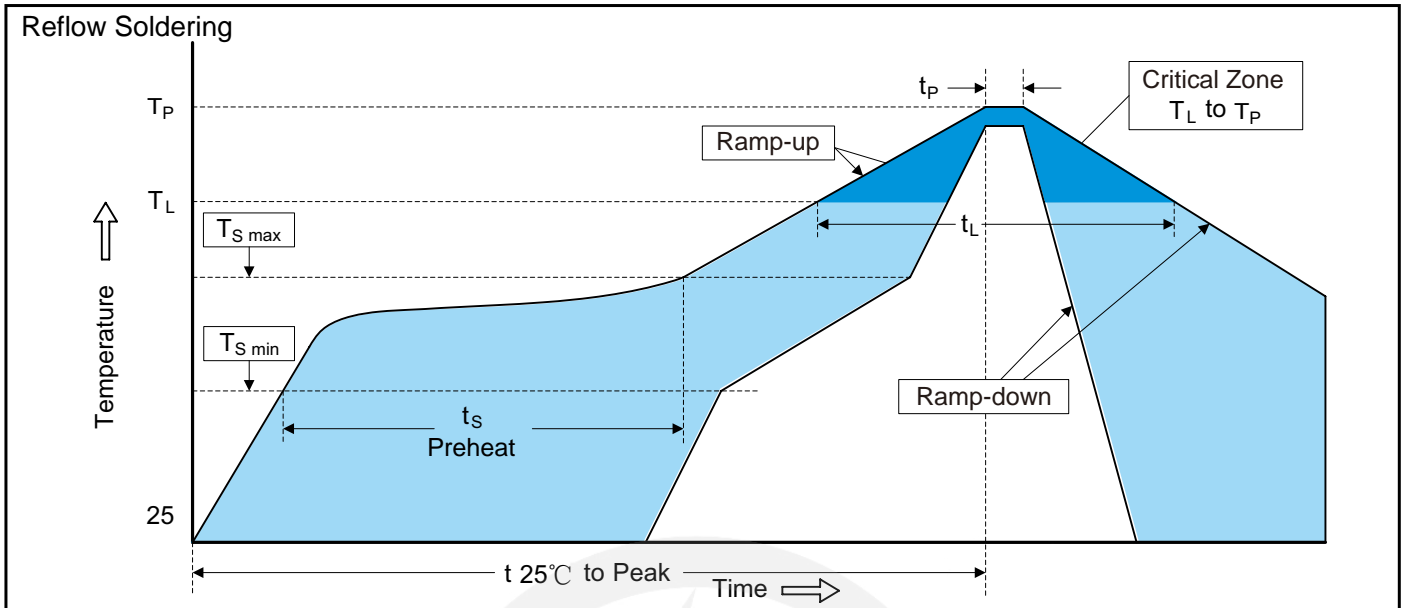

Recommended Conditions

Profile Feature	Pb-Free Assembly
Average ramp-up rate (T_L to T_P)	3°C/second max.
Preheat	
-Temperature Min ($T_{S\ min}$)	150°C
-Temperature Max ($T_{S\ max}$)	200°C
-Time (min to max) (t_s)	60-180 seconds
$T_{S\ max}$ to T_L	
-Ramp-up Rate	3°C/second max.
Time maintained above:	
-Temperature (T_L)	217°C
-Time (t_L)	60-150 seconds
Peak Temperature (T_P)	260°C
Time within 5°C of actual Peak Temperature (t_p)	20-40 seconds
Ramp-down Rate	6°C/second max.
Time 25°C to Peak Temperature	8 minutes max.

Important Notice and Disclaimer

Leading-Tech reserves the right to make changes to this document and its products and specifications at any time without notice.

Customers should obtain and confirm the latest product information and specifications before final design, purchase or use.

Leading-Tech makes no warranty, representation or guarantee regarding the suitability of its products for any particular purpose, not does Leading-Tech assume any liability for application assistance or customer product design.

Leading-Tech does not warrant or accept any liability with products which are purchase or used for any unintended or unauthorized application.

No license is granted by implication or otherwise under any intellectual property rights of Leading-Tech.

Leading-Tech products are not authorized for use as critical components in life support devices or systems without express written approval of Leading-Tech.

Version Update Information

Series NO.	Enactment/Revision Date	Effective Date	Version	Revision Content	Revision Reason	Revision Person	Note
01	2024.10.17	2024.10.17	3.0	New file	/	Ding	
02	2025.06.11	2025.06.11	3.1	Update packaging information	/	Ding	
03	2026.03.05	2026.03.05	3.2	Package outline E1(max)=2.6mm	/	Ding	