

NPN General Purpose Amplifier

Features

- Epoxy Meets UL 94 V-0 Flammability Rating
- Surface Mount SOT-523 Package
- Tape specification: Conductive
- Lead free in comply with EU RoHS 2011/65/EU directives

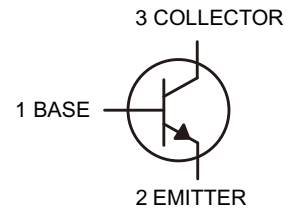
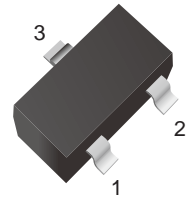

Part Number	Marking	Shipping	Reel
LTM3904T52-TR3	AM or 1N	3000PCS Tape&Reel	7 inchs
LTM3904T52-TR8	AM or 1N	8000PCS Tape&Reel	7 inchs

Maximum Ratings (Ta=25°C unless otherwise noted)

Symbol	Parameter	Value	Unit
V_{CBO}	Collector-Base Voltage	60	V
V_{CEO}	Collector-Emitter Voltage	40	V
V_{EBO}	Emitter-Base Voltage	6	V
I_C	Collector Current	200	mA
P_C	Collector Power Dissipation	150	mW
$R_{\theta JA}$	Thermal Resistance From Junction To Ambient	833	°C/W
T_j	Junction Temperature	150	°C
T_{stg}	Storage Temperature	-55~+150	°C

Electrical Characteristics (@ 25°C Unless Otherwise Specified)

Symbol	Parameter	Test Conditions	Min	Typ	Max	Unit
$V_{(BR)CEO}$	Collector-Emitter Breakdown Voltage	$I_C=1.0mA, I_B=0$	40			V
$V_{(BR)CBO}$	Collector-Base Breakdown Voltage	$I_C=10\mu A, I_E=0$	60			V
$V_{(BR)EBO}$	Emitter-Base Breakdown Voltage	$I_E=10\mu A, I_C=0$	6.0			V
I_{CBO}	Collector Cut-off Current	$V_{CB}=60V, I_E=0$			100	nA
I_{CEX}	Collector Cut-off Current	$V_{CE}=30V, V_{EB(off)}=3V$			50	nA
I_{EBO}	Emitter Cut-off Current	$V_{EB}=5V, I_C=0$			100	nA
h_{FE}	DC Current Gain	$I_C=0.1mA, V_{CE}=1.0V$	40			
		$I_C=1.0mA, V_{CE}=1.0V$	70			
		$I_C=10mA, V_{CE}=1.0V$	100		300	
		$I_C=50mA, V_{CE}=1.0V$	60			
$V_{CE(sat)}$	Collector-Emitter Saturation Voltage	$I_C=10mA, I_B=1.0mA$			0.2	V
		$I_C=50mA, I_B=5.0mA$			0.3	
$V_{BE(sat)}$	Base-Emitter Saturation Voltage	$I_C=10mA, I_B=1.0mA$	0.65		0.85	V
		$I_C=50mA, I_B=5.0mA$			0.95	
f_T	Transition Frequency	$I_C=10mA, V_{CE}=20V, f=100MHz$	200			MHZ
C_{ob}	Output Capacitance	$V_{CB}=5.0V, I_E=0, f=1.0MHz$			4.0	pF
C_{ib}	Input Capacitance	$V_{BE}=0.5V, I_C=0, f=1.0MHz$			8.0	pF

Switching Characteristics

Symbol	Parameter	Test Conditions	Min	Typ	Max	Unit
td	Delay Time	$V_{CC}=3.0V, V_{BE(off)}=-0.5V, I_C=10mA, I_{B1}=1.0mA$			35	nS
tr	Rise Time				35	nS
ts	Storage Time	$V_{CC}=3.0V, I_C=10mA, I_{B1}=I_{B2}=1.0mA$			200	nS
tf	Fall Time				50	nS



Characteristics Curves

Fig.1 Static Characteristic

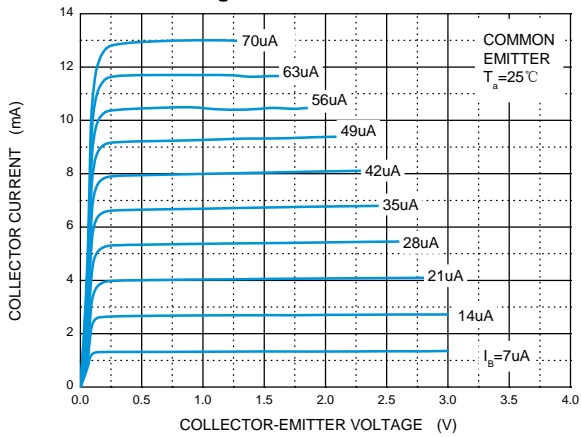

Fig.2 DC Current Gain Characteristics

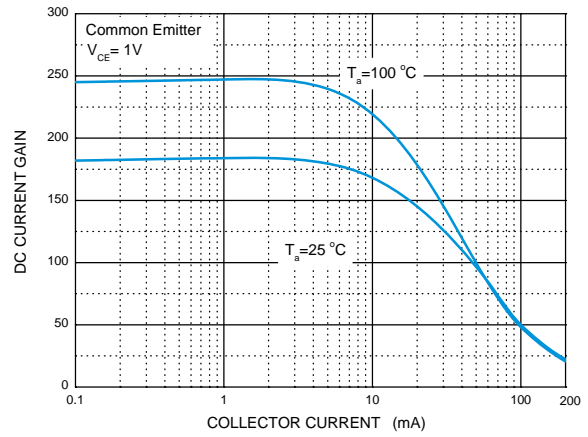

Fig.3 Collector-Emitter Saturation Voltage Characteristics

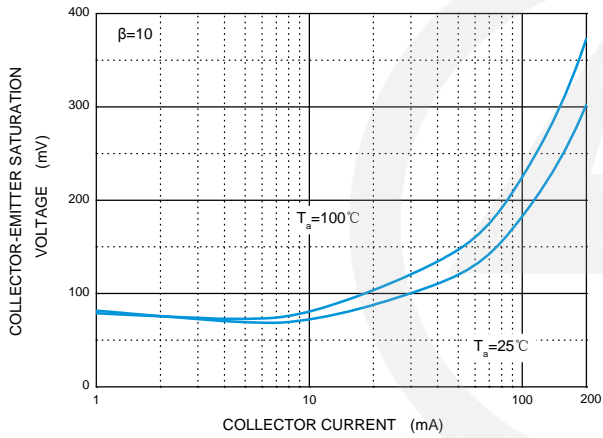

Fig.4 Base-Emitter Saturation Voltage

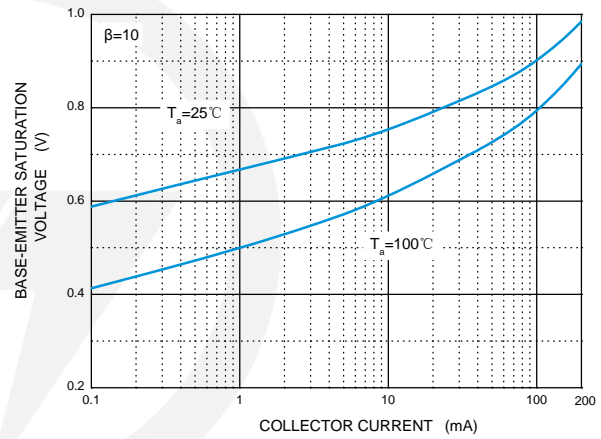

Fig.5 Base-Emitter Voltage Characteristics

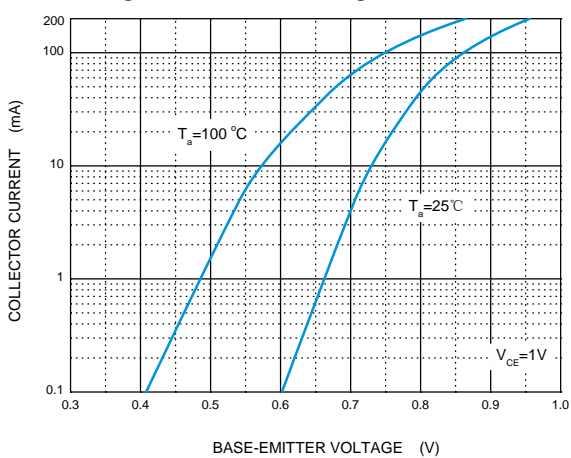
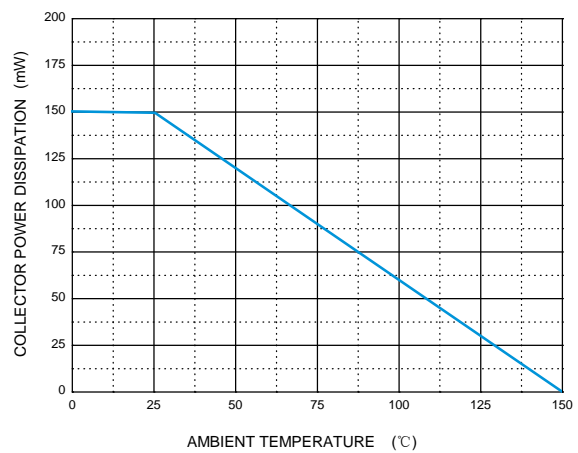
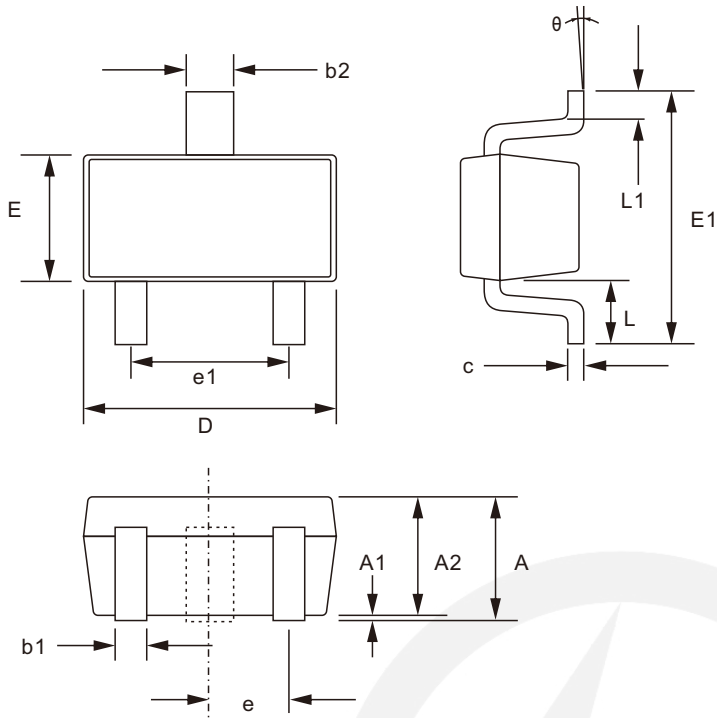

Fig.6 Collector Power Derating Curve



SOT-523 Package Outline



Unit: mm

SYMBOL	DIMENSIONS	
	MIN.	MAX.
A	0.70	0.90
A1	0.00	0.10
A2	0.70	0.80
b1	0.15	0.25
b2	0.25	0.35
c	0.10	0.20
D	1.50	1.70
E	0.70	0.90
E1	1.45	1.75
e	0.50 TYP.	
e1	0.90	1.10
L	0.40 TYP.	
L1	0.10	0.30
θ	0°	8°

SOT-523 Suggested Pad Layout

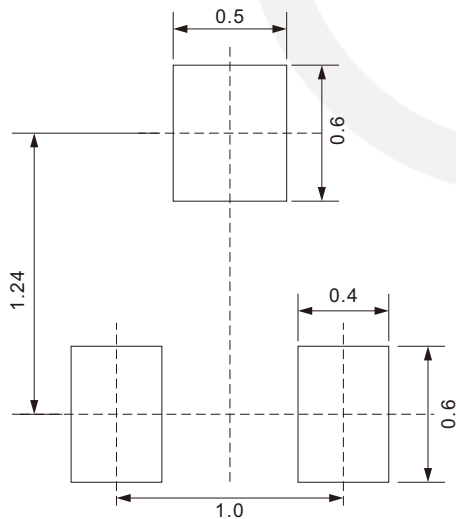

Note:

1. Controlling dimension: in millimeters.
2. General tolerance: $\pm 0.05\text{mm}$
3. The pad layout is for reference purpose only.

Carrier Tape Dimensions

Unit : mm

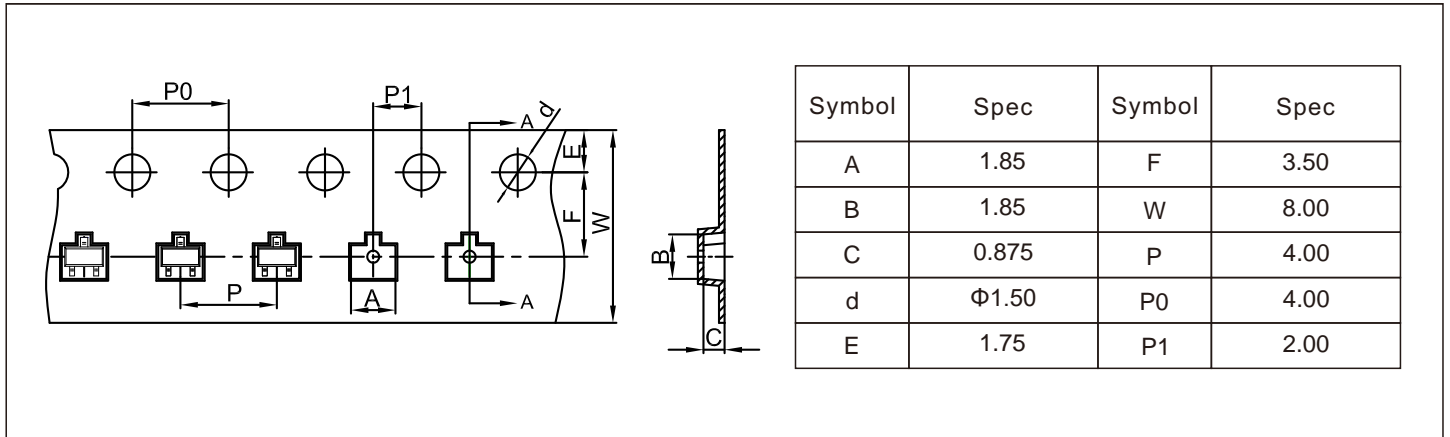

Reel Dimensions

Unit : mm

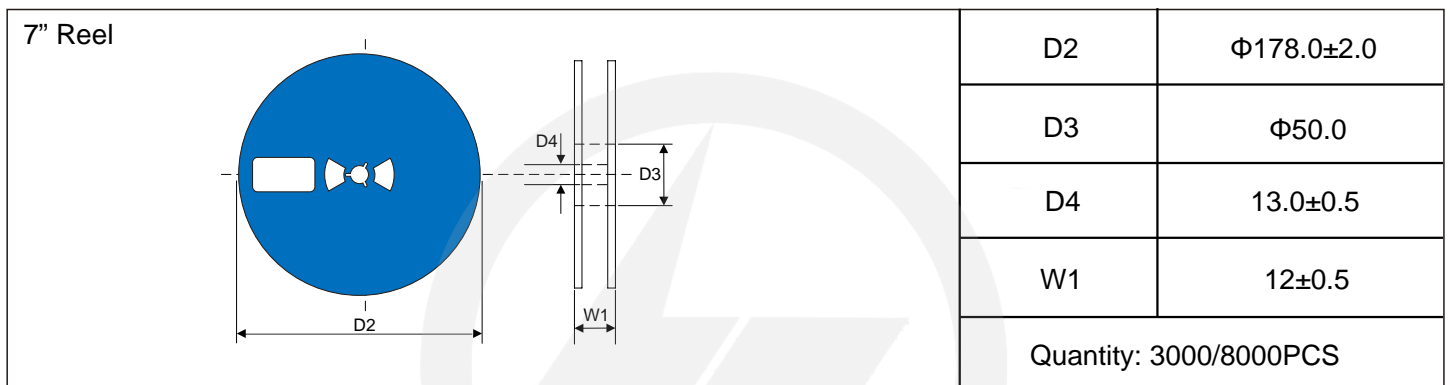

Packaging

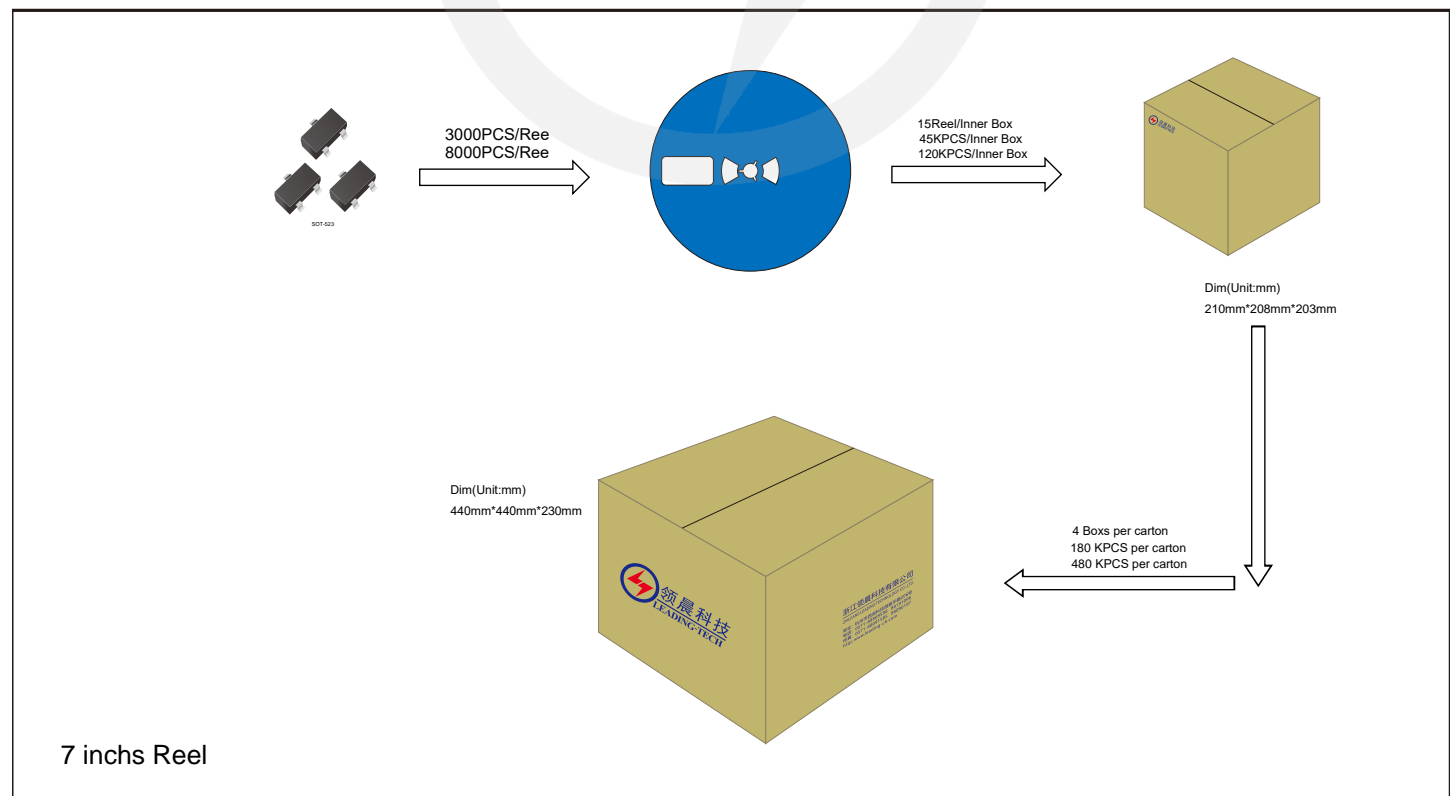



Recommended Soldering Conditions

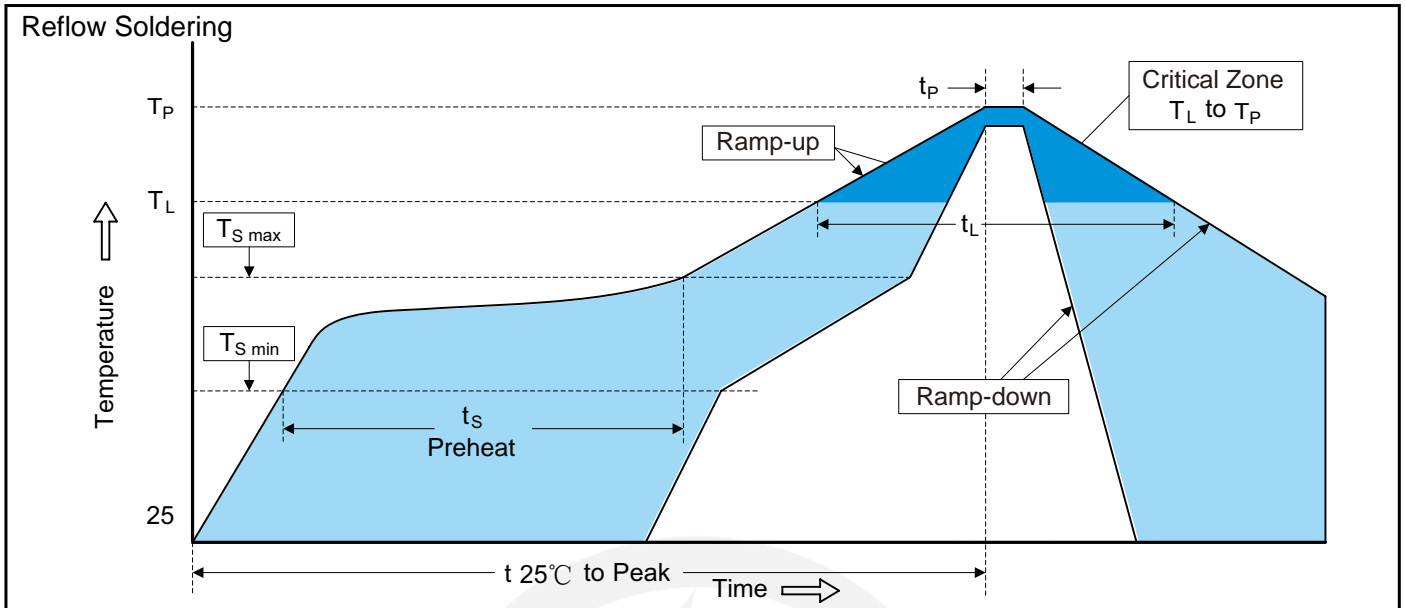

Recommended Conditions

Profile Feature	Pb-Free Assembly
Average ramp-up rate (T _L to T _P)	3°C/second max.
Preheat	
-Temperature Min (T _{S min})	150°C
-Temperature Max (T _{S max})	200°C
-Time (min to max) (t _s)	60-180 seconds
T _{S max} to T _L	
-Ramp-up Rate	3°C/second max.
Time maintained above:	
-Temperature (T _L)	217°C
-Time (t _L)	60-150 seconds
Peak Temperature (T _P)	260°C
Time within 5°C of actual Peak Temperature (t _p)	20-40 seconds
Ramp-down Rate	6°C/second max.
Time 25°C to Peak Temperature	8 minutes max.

Important Notice and Disclaimer

Leading-Tech reserves the right to make changes to this document and its products and specifications at any time without notice.

Customers should obtain and confirm the latest product information and specifications before final design, purchase or use.

Leading-Tech makes no warranty, representation or guarantee regarding the suitability of its products for any particular purpose, not does Leading-Tech assume any liability for application assistance or customer product design.

Leading-tech does not warrant or accept any liability with products which are purchase or used for any unintended or unauthorized application.

No license is granted by implication or otherwise under any intellectual property rights of Leading-Tech.

Leading-Tech products are not authorized for use as critical components in life support devices or systems without express written approval of Leading-tech.

Version Update Information

Series NO.	Enactment/Revision Date	Effective Date	Version	Revision content	Revision Reason	Revision Person	Note
01	2024.10.2	2024.10.2	3.0	New File	/	Ding	