

## P-Channel Mosfet

### Features

- Surface Mount Package
- P-Channel Switch with Low  $R_{DS(on)}$
- Operated at Low Logic Level Gate Drive
- Lead free in comply with EU RoHS 2011/65/EU directives

### Applications

- Load/Power Switching
- Interfacing, Logic Switching
- Battery Management for Ultra Small Portable Electronics

### Ordering Information

Part Number	Marking	Shipping	Reel
LTM3139P-TR3	39K	3000PCS Tape&Reel	7 inchs
LTM3139P-TR12	39K	12000PCS Tape&Reel	13 inchs

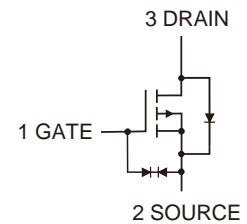
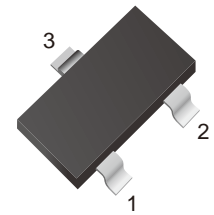

### Absolute Maximum Ratings ( $T_a=25^\circ\text{C}$ )

Symbol	Parameter	Value	Unit
$V_{DS}$	Drain-Source Voltage	-20	V
$V_{GS}$	Gate-Source Voltage	$\pm 12$	V
$I_D$	Continuous Drain Current	-0.5	A
$I_{DM}$	Pulsed Drain Current ( $t_p=10s$ )	-1.2	A
$P_D$	Power Dissipation	350	mW
$R_{\theta JA}$	Thermal Resistance From Junction To Ambient ( $t \leq 5s$ )	350	$^\circ\text{C/W}$
$T_J, T_{stg}$	Operation Junction And Storage Temperature Range	-55 ~ +150	$^\circ\text{C}$

### Electrical Characteristics ( $T_a=25^\circ\text{C}$ unless otherwise specified)

Symbol	Parameter	Test conditions	Min	Typ	Max	Unit
<b>Static</b>						
$V_{(BR)DSS}$	Drain-source breakdown voltage	$V_{GS}=0, I_D=250\mu\text{A}$	-20			V
$V_{GS(th)}$	Gate threshold voltage	$V_{DS}=V_{GS}, I_D=-250\mu\text{A}$	-0.35		-1.2	V
$I_{GSS}$	Gate-body leakage current	$V_{DS}=0, V_{GS}=\pm 10V$		$\pm 1.5$	$\pm 10$	$\mu\text{A}$
$I_{DSS}$	Zero gate voltage drain current	$V_{DS}=-20V, V_{GS}=0V$			-1	$\mu\text{A}$
$R_{DS(on)}$	Drain-source on-resistance <sup>a</sup>	$V_{GS}=-4.5V, I_D=-0.5A$		580	700	m $\Omega$
		$V_{GS}=-2.5V, I_D=-0.5A$		900	1200	m $\Omega$
		$V_{GS}=-1.8V, I_D=-0.5A$		1400	1600	m $\Omega$
$V_{SD}$	Diode forward voltage	$I_S=-0.5A, V_{GS}=0V$		-0.95	-1.2	V
<b>Dynamic</b>						
$C_{iss}$	Input capacitance	$V_{DS}=-10V, V_{GS}=0V, f=1\text{MHZ}$		71		pF
$C_{oss}$	Output capacitance			20		
$C_{rss}$	Reverse transfer capacitance <sup>b</sup>			15		
<b>Switching<sup>b</sup></b>						
$t_{d(on)}$	Turn-on delay time	$V_{GS}=-4.5V, V_{DD}=-10V,$ $R_L=2.5\Omega, R_{GEN}=3\Omega$		4		nS
$t_r$	Rise time			19		
$t_{d(off)}$	Turn-off delay time			16		
$t_f$	Fall time			25		

Note:

a. Pulse Test : Pulse width  $\leq 300\mu\text{s}$ , duty cycle  $\leq 2\%$ .

b. Guaranteed by design, not subject to producing.



Characteristics Curves

Fig.1 Output Characteristics

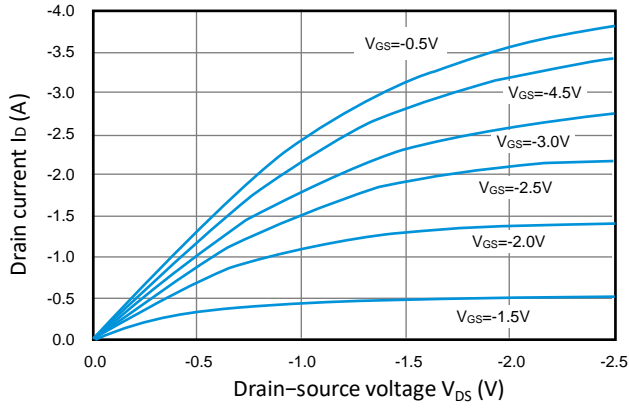

Fig.2 Transfer Characteristics

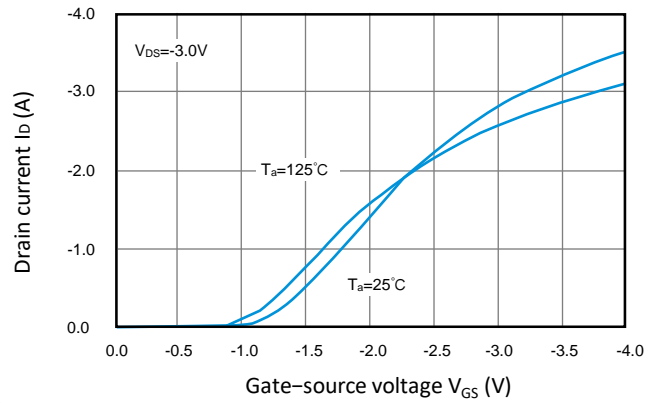

Fig.3 Capacitance Characteristics

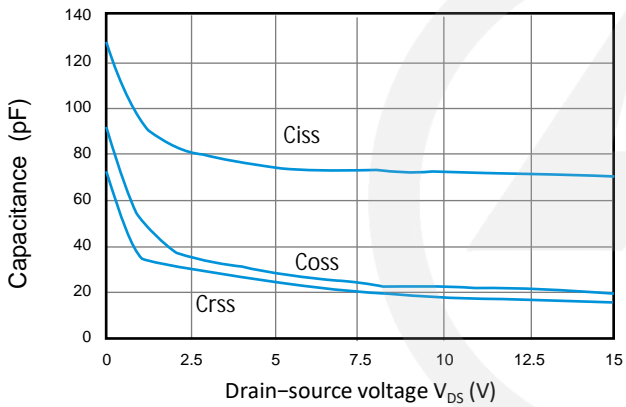

Fig.4 Gate Charge

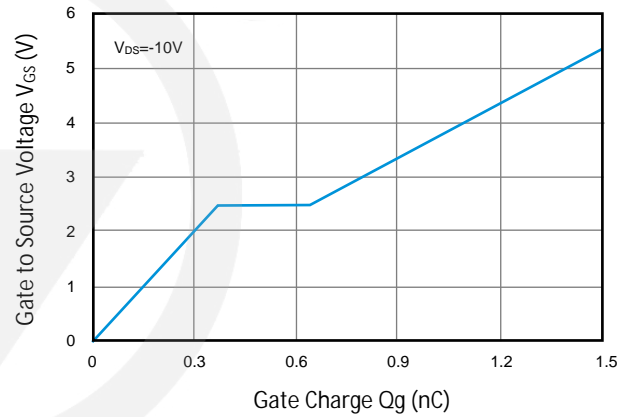

Fig.5 Drain-Source on Resistance

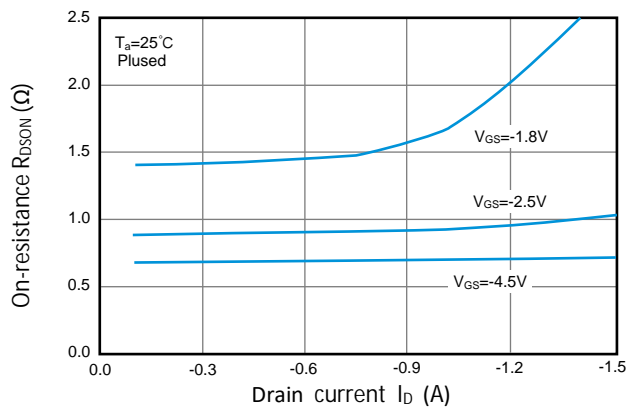
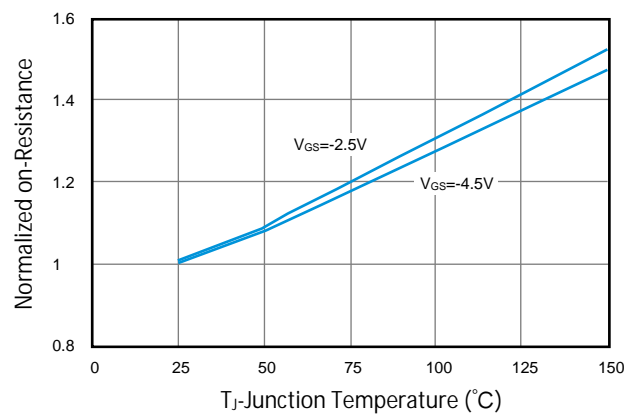
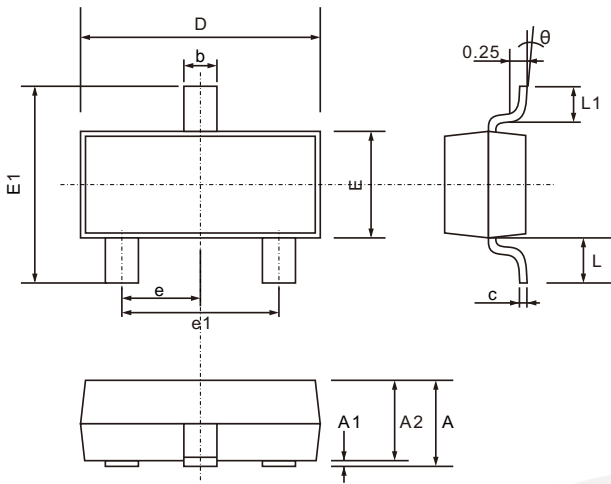

Fig.5 Drain-Source on Resistance



**SOT-23 Package Outline**

Unit: mm



SYMBOL	DIMENSIONS	
	MIN.	MAX.
A	0.900	1.200
A1	0.000	0.100
A2	0.900	1.050
b	0.300	0.500
c	0.080	0.200
D	2.700	3.100
E	1.200	1.400
E1	2.200	2.600
e	0.950 TYP.	
e1	1.750	2.050
L	0.550 TYP.	
L1	0.300	0.500
$\theta$	0°	8°

**SOT-23 Suggested Pad Layout**

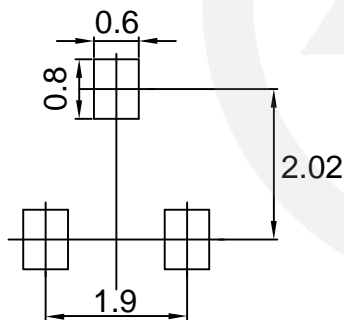

- Note:
1. Controlling dimension: in millimeters.
  2. General tolerance:  $\pm 0.05\text{mm}$
  3. The pad layout is for reference purpose only.

**Carrier Tape Dimensions**

Unit : mm

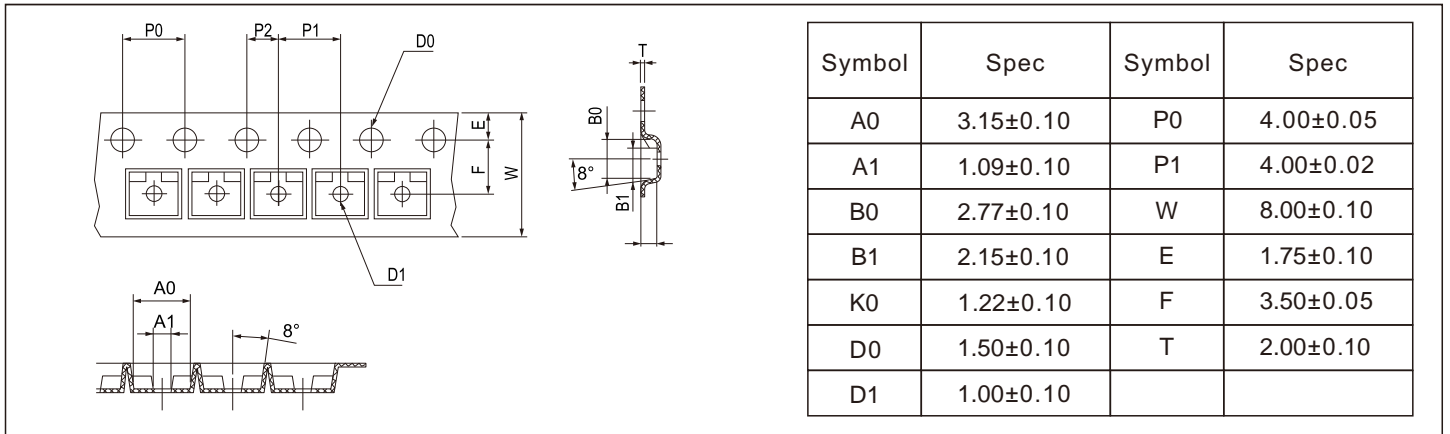

**Reel Dimensions**

Unit : mm

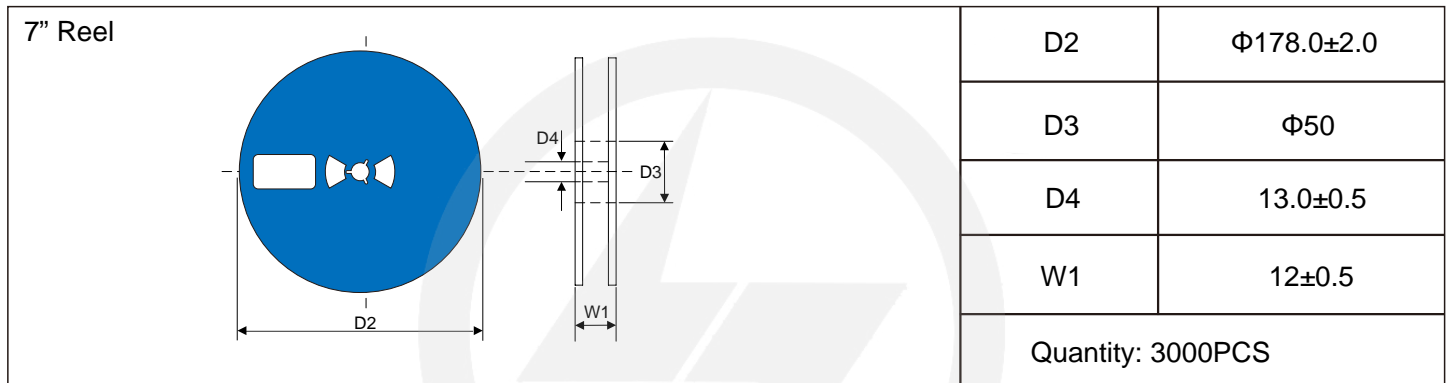

**Reel Dimensions**

Unit : mm

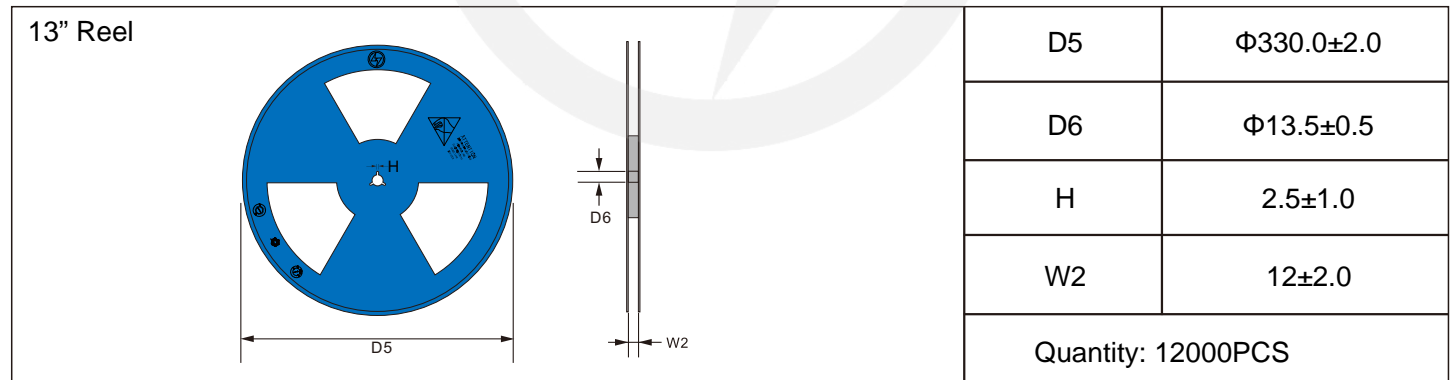

**Packaging**

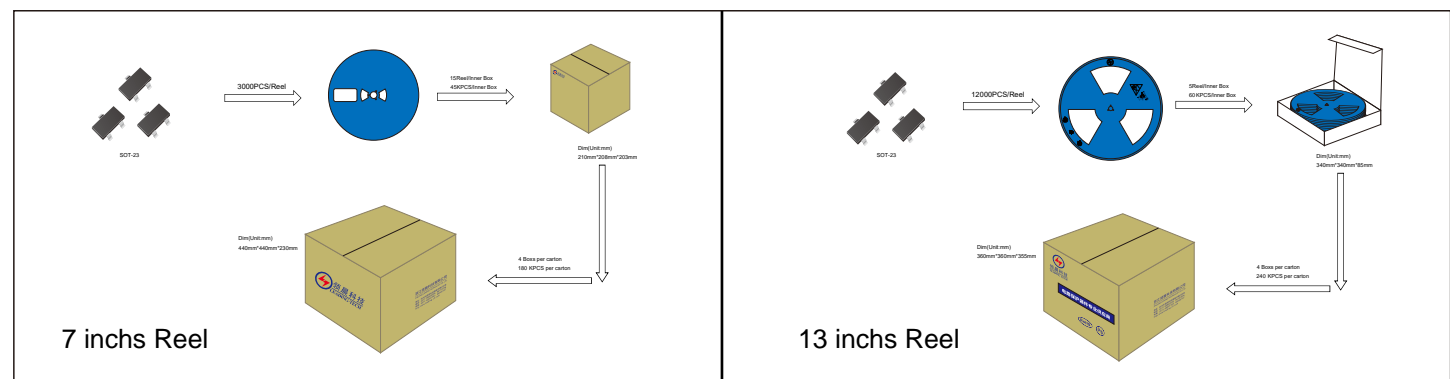



Recommended Soldering Conditions



Recommended Conditions

Profile Feature	Pb-Free Assembly
Average ramp-up rate (T <sub>L</sub> to T <sub>P</sub> )	3°C/second max.
Preheat	
-Temperature Min (T <sub>S min</sub> )	150°C
-Temperature Max (T <sub>S max</sub> )	200°C
-Time (min to max) (t <sub>s</sub> )	60-180 seconds
T <sub>S max</sub> to T <sub>L</sub>	
-Ramp-up Rate	3°C/second max.
Time maintained above:	
-Temperature (T <sub>L</sub> )	217°C
-Time (t <sub>L</sub> )	60-150 seconds
Peak Temperature (T <sub>P</sub> )	260°C
Time within 5°C of actual Peak Temperature (t <sub>p</sub> )	20-40 seconds
Ramp-down Rate	6°C/second max.
Time 25°C to Peak Temperature	8 minutes max.

## Important Notice and Disclaimer

Leading-Tech reserves the right to make changes to this document and its products and specifications at any time without notice.

Customers should obtain and confirm the latest product information and specifications before final design, purchase or use.

Leading-Tech makes no warranty, representation or guarantee regarding the suitability of its products for any particular purpose, not does Leading-Tech assume any liability for application assistance or customer product design.

Leading-Tech does not warrant or accept any liability with products which are purchase or used for any unintended or unauthorized application.

No license is granted by implication or otherwise under any intellectual property rights of Leading-Tech.

Leading-Tech products are not authorized for use as critical components in life support devices or systems without express written approval of Leading-Tech.

## Version Update Information

Series NO.	Enactment/Revision Date	Effective Date	Version	Revision Content	Revision Reason	Revision Person	Note
01	2025.02.21	2025.02.21	3.0	New file	/	Ding	
02	2026.03.05	2026.03.05	3.1	Package outline E1(max)=2.6mm	/	Ding	