

## N-Channel Mosfet

### Features

- Low on-resistance.
- Fast switching speed.
- Low voltage drive makes this device ideal for Portable equipment.
- Easily designed drive circuits.
- Easy to parallel.
- Lead free in comply with EU RoHS 2011/65/EU directives

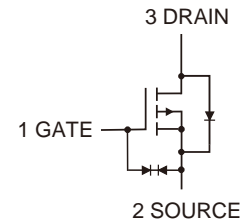
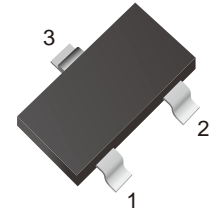

### Ordering Information

Part Number	Marking	Shipping	Reel
LTM3018N-TR3	KN	3000PCS Tape&Reel	7 inches
LTM3018N-TR12	KN	12000PCS Tape&Reel	13 inches

### Absolute Maximum Ratings (Ta=25°C)

Symbol	Parameter	Value	Unit
V <sub>DS</sub>	Drain-Source Voltage	30	V
V <sub>GS</sub>	Gate-Source Voltage	±20	V
I <sub>D</sub>	Continuous Drain Current	0.1	A
P <sub>D</sub>	Power Dissipation	350	mW
R <sub>θJA</sub>	Thermal Resistance From Junction To Ambient (t ≤ 5s)	357	°C/W
T <sub>J</sub> , T <sub>stg</sub>	Operation Junction And Storage Temperature Range	-55 ~ +150	°C

### Electrical Characteristics (Ta=25°C unless otherwise specified)

Symbol	Parameter	Test conditions	Min	Typ	Max	Unit
<b>Static</b>						
V <sub>(BR)DSS</sub>	Drain-source breakdown voltage	V <sub>GS</sub> =0, I <sub>D</sub> =10μA	30			V
V <sub>GS(th)</sub>	Gate threshold voltage	V <sub>DS</sub> =3V, I <sub>D</sub> =100μA	0.8		1.5	V
I <sub>GSS</sub>	Gate-body leakage current	V <sub>DS</sub> =0, V <sub>GS</sub> =±20V			±2	μA
I <sub>DSS</sub>	Zero gate voltage drain current	V <sub>DS</sub> =30V, V <sub>GS</sub> =0V			0.2	μA
R <sub>DS(on)</sub>	Drain-source on-resistance	V <sub>GS</sub> =4.5V, I <sub>D</sub> =10mA		1.5	3	Ω
		V <sub>GS</sub> =2.5V, I <sub>D</sub> =1mA		2.8	5	Ω
g <sub>FS</sub>	Forward Transconductance	V <sub>DS</sub> =3V, I <sub>D</sub> =10mA	20			mS
V <sub>SD</sub>	Diode forward voltage	I <sub>S</sub> =0.1A, V <sub>GS</sub> =0V		0.8	1.2	V
<b>Dynamic</b>						
C <sub>iss</sub>	Input capacitance	V <sub>DS</sub> =5V, V <sub>GS</sub> =0V, f=1MHZ		11		pF
C <sub>oss</sub>	Output capacitance			8		
C <sub>rss</sub>	Reverse transfer capacitance			5		
<b>Switching<sup>b</sup></b>						
t <sub>d(on)</sub>	Turn-on delay time	V <sub>GS</sub> =5V, V <sub>DD</sub> =5V, I <sub>D</sub> =10mA, R <sub>L</sub> =500Ω, R <sub>GEN</sub> =10Ω		15		nS
t <sub>r</sub>	Rise time			35		
t <sub>d(off)</sub>	Turn-off delay time			80		
t <sub>f</sub>	Fall time			80		



### Characteristics Curves

Fig.1 Output Characteristics

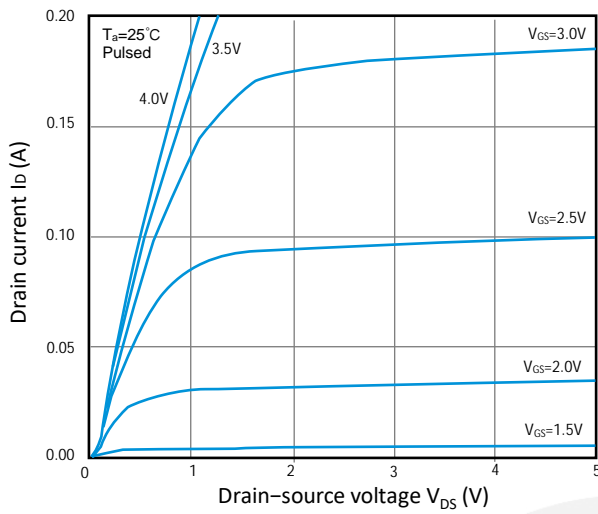

Fig.2 Transfer Characteristics

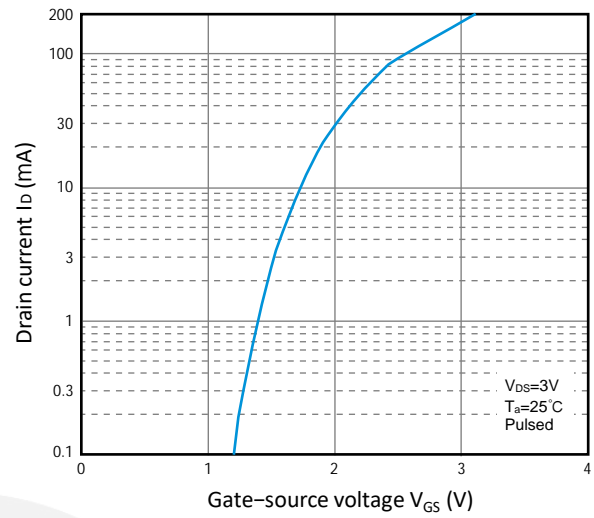

Fig.3  $R_{DS(ON)}$  —  $I_D$

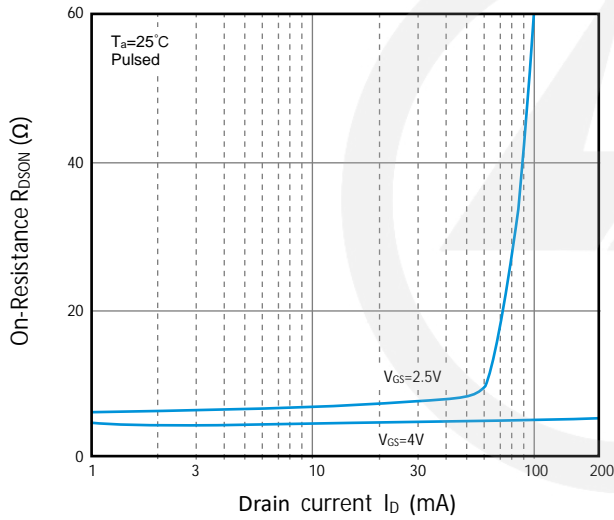

Fig.4  $R_{DS(ON)}$  —  $V_{GS}$

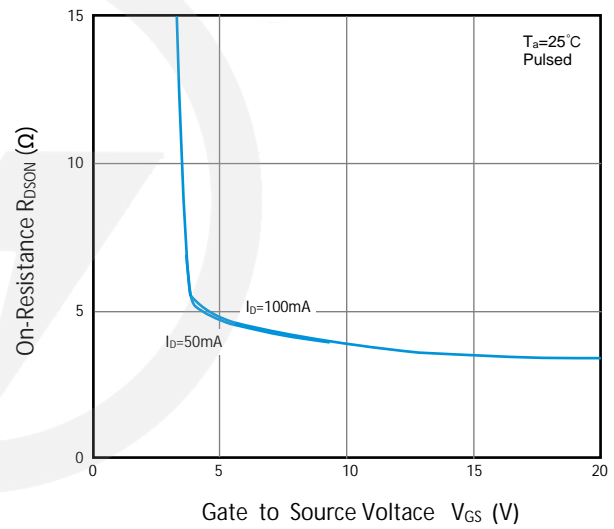
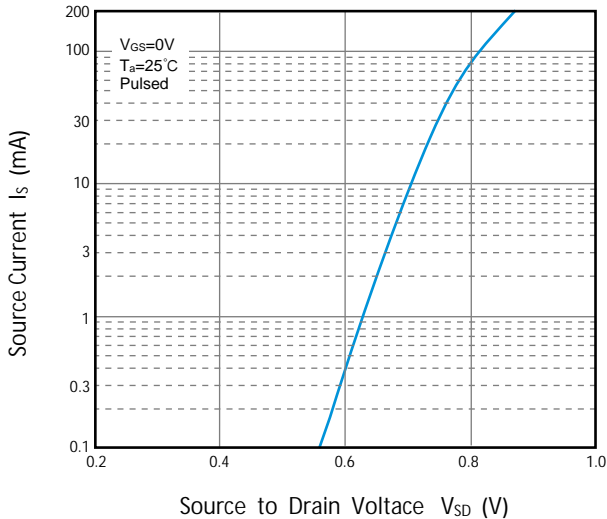
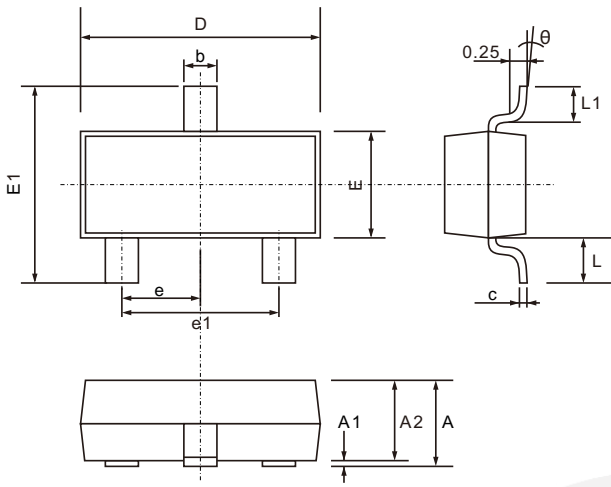

Fig.5  $I_S$  —  $V_{SD}$



**SOT-23 Package Outline**

Unit: mm



SYMBOL	DIMENSIONS	
	MIN.	MAX.
A	0.900	1.200
A1	0.000	0.100
A2	0.900	1.050
b	0.300	0.500
c	0.080	0.200
D	2.700	3.100
E	1.200	1.400
E1	2.200	2.600
e	0.950 TYP.	
e1	1.750	2.050
L	0.550 TYP.	
L1	0.300	0.500
$\theta$	0°	8°

**SOT-23 Suggested Pad Layout**

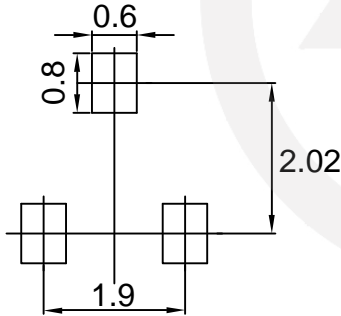

Note:  
 1. Controlling dimension: in millimeters.  
 2. General tolerance:  $\pm 0.05\text{mm}$   
 3. The pad layout is for reference purpose only.

**Carrier Tape Dimensions**

Unit : mm

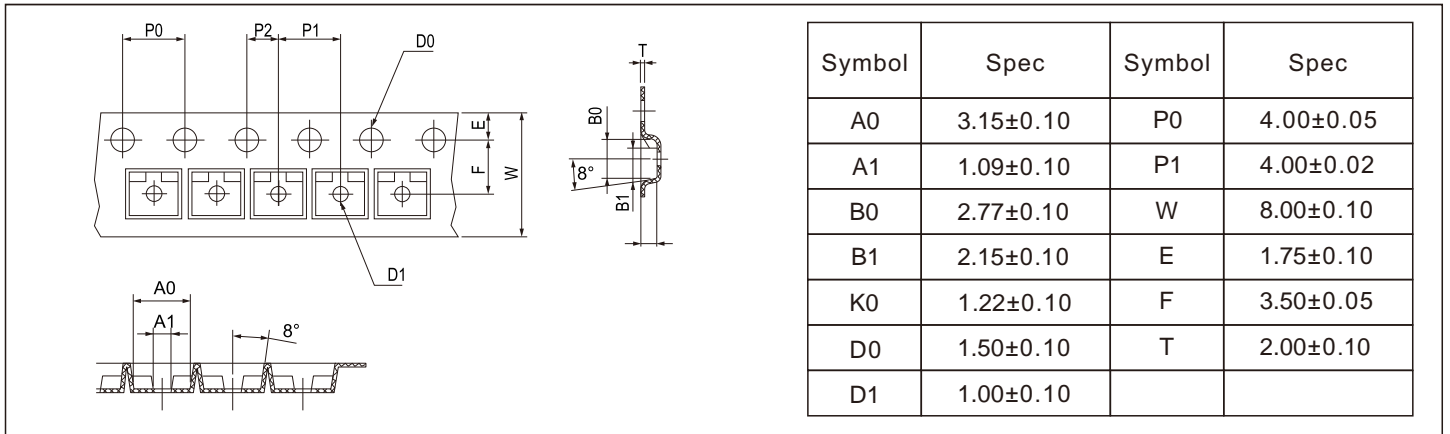

**Reel Dimensions**

Unit : mm

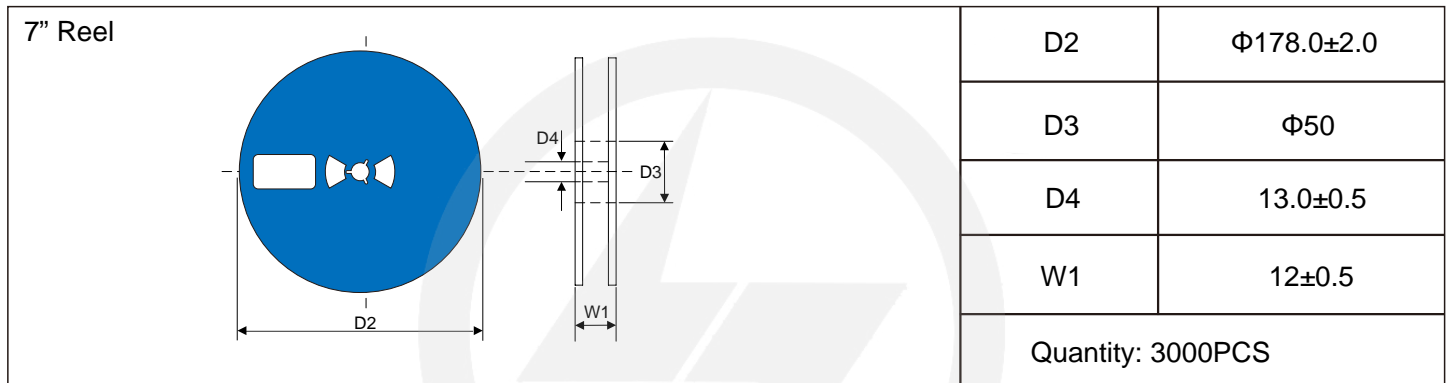

**Reel Dimensions**

Unit : mm

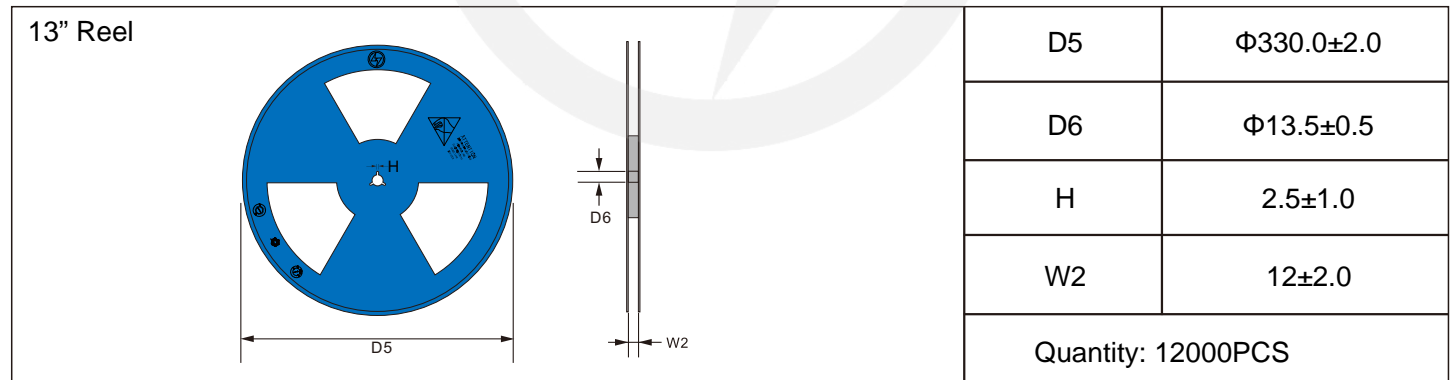

**Packaging**

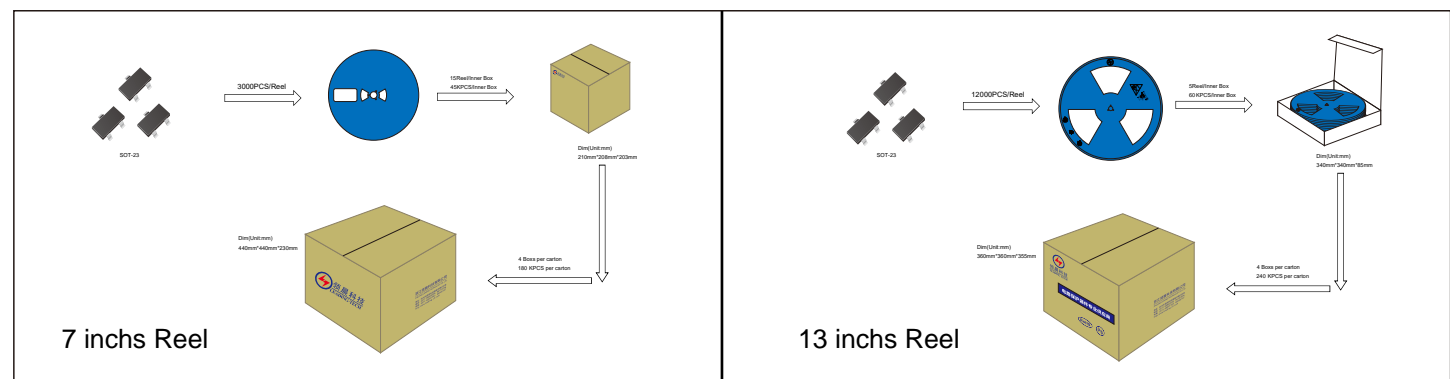



Recommended Soldering Conditions



Recommended Conditions

Profile Feature	Pb-Free Assembly
Average ramp-up rate (T <sub>L</sub> to T <sub>P</sub> )	3°C/second max.
Preheat	
-Temperature Min (T <sub>S min</sub> )	150°C
-Temperature Max (T <sub>S max</sub> )	200°C
-Time (min to max) (t <sub>s</sub> )	60-180 seconds
T <sub>S max</sub> to T <sub>L</sub>	
-Ramp-up Rate	3°C/second max.
Time maintained above:	
-Temperature (T <sub>L</sub> )	217°C
-Time (t <sub>L</sub> )	60-150 seconds
Peak Temperature (T <sub>P</sub> )	260°C
Time within 5°C of actual Peak Temperature (t <sub>p</sub> )	20-40 seconds
Ramp-down Rate	6°C/second max.
Time 25°C to Peak Temperature	8 minutes max.

## Important Notice and Disclaimer

Leading-Tech reserves the right to make changes to this document and its products and specifications at any time without notice.

Customers should obtain and confirm the latest product information and specifications before final design, purchase or use.

Leading-Tech makes no warranty, representation or guarantee regarding the suitability of its products for any particular purpose, not does Leading-Tech assume any liability for application assistance or customer product design.

Leading-Tech does not warrant or accept any liability with products which are purchase or used for any unintended or unauthorized application.

No license is granted by implication or otherwise under any intellectual property rights of Leading-Tech.

Leading-Tech products are not authorized for use as critical components in life support devices or systems without express written approval of Leading-Tech.

## Version Update Information

Series NO.	Enactment/Revision Date	Effective Date	Version	Revision Content	Revision Reason	Revision Person	Note
01	2025.03.05	2025.03.05	3.0	New file	/	Ding	
02	2026.03.05	2026.03.05	3.1	Package outline E1(max)=2.6mm	/	Ding	