

P-Channel MOSFET

Features

- $V_{DS} = -20V$, $I_D = -4.1A$
- $R_{DS(ON)} < 46m\Omega$ ($V_{GS} = -4.5V$)
- $R_{DS(ON)} < 70m\Omega$ ($V_{GS} = -2.5V$)
- High Power and Current Handling Capability
- Lead Free Product is Acquired
- Surface Mount Package
- Lead free in comply with EU RoHS 2011/65/EU directives
- Moisture Sensitivity Level 3

Mechanical Data

- Case: SOT-23
- Approx. Weight: 8.1mg

Ordering Information

Part Number	Marking	Shipping	Reel
LTM2305PA-TR3	P5A	3000PCS Tape&Reel	7 inches
LTM2305PA-TR12	P5A	12000PCS Tape&Reel	13 inches

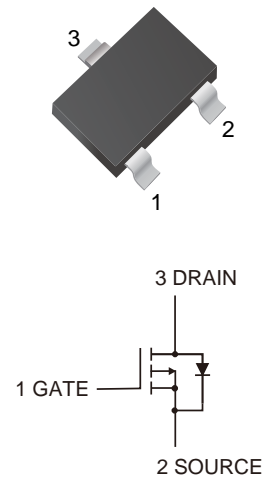

Maximum Ratings ($T_a = 25^\circ C$)

Symbol	Parameter	Value	Units
V_{DSS}	Drain-source Voltage	- 20	V
V_{GS}	Gate - source - Voltage	± 12	V
I_D	Continuous Drain Current	$T_C = 25^\circ C$	- 4.1
		$T_C = 100^\circ C$	- 3.2
I_{DM}	Pulsed Drain Current (note 1)	- 15	A
P_D	Power Dissipation	1.7	W
T_J, T_{STG}	Operating And Storage Temperature Range	- 55 to 150	$^\circ C$
$R_{\theta JA}$	Thermal Resistance from Junction to Ambient	74	$^\circ C/W$

Electrical Characteristics ($T_a = 25^\circ C$)

Symbol	Parameter	Test Conditions	Min	Typ	Max	Units
$V_{(BR)DSS}$	Drain-source Breakdown Voltage	$V_{GS} = 0V, I_D = -250\mu A$	- 20			V
I_{DSS}	Zero Gate Voltage Drain Current	$V_{DS} = -20V, V_{GS} = 0V$			- 1	μA
I_{GSS}	Gate-body Leakage Current	$V_{DS} = 0V, V_{GS} = \pm 12V$			± 100	nA
$V_{GS(th)}$	Gate-Threshold Voltage (note 2)	$V_{DS} = V_{GS}, I_D = -250\mu A$	- 0.45	- 0.7	- 1.0	V
$R_{DS(on)}$	Drain-source On-Resistance (note 2)	$V_{GS} = -4.5V, I_D = -4.1A$		35	46	$m\Omega$
		$V_{GS} = -2.5V, I_D = -3A$		46	70	
g_{FS}	Forward Transconductance	$V_{DS} = -5V, I_D = -2A$		6		S

Dynamic Characteristics

C_{iss}	Input Capacitance	$V_{DS} = -10V$		954		pF
C_{oss}	Output Capacitance	$V_{GS} = 0V$		131		
C_{rss}	Reverse Transfer Capacitance	$f = 1MHz$		103		
Q_g	Total Gate Charge	$V_{DS} = -10V$		7.8		nC
Q_{gs}	Gate - Source Charge	$I_D = -4.1A$		1.2		
Q_{gd}	Gate - Drain ("Miller") Charge	$V_{GS} = -4.5V$		1.6		

Switching Characteristics

$t_{d(on)}$	Turn-on Delay Time	$V_{DD} = -10V, I_D = -3.3A,$ $R_G = 1\Omega, V_{GEN} = -4.5V,$ $R_L = 1.2\Omega$		12		ns
t_r	Turn-on Rise Time			35		
$t_{d(off)}$	Turn-off Delay Time			30		
t_f	Turn-off Fall Time			10		

Drain-Source Diode Characteristics and Maximum Ratings

I_S	Maximum Continuous Drain to Source Diode Forward Current			-4.1	A
I_{SM}	Maximum Pulsed Drain to Source Diode Forward Current			-15	A
V_{SD}	Drain to Source Diode Forward Voltage	$V_{GS} = 0V, I_S = -4.1A$		-1.2	V
t_{rr}	Reverse Recovery Time	$V_{GS} = 0V, I_S = -4.1A,$ $di/dt = 100A/\mu s$		20	ns
Q_{rr}	Reverse Recovery Charge			9	nC

Notes:

1. Repetitive Rating: Pulse Width Limited by Maximum Junction Temperature
2. Pulse Test : Pulse Width $\leq 300\mu s$, Duty Cycle $\leq 2\%$

Typical Performance Characteristics

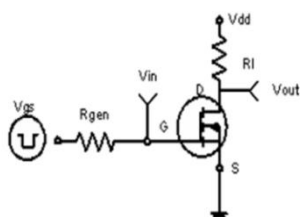

Figure1: Switching Test Circuit

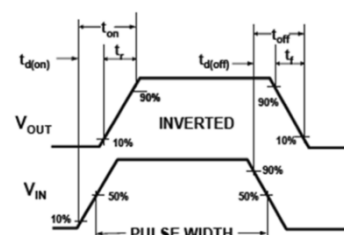

Figure2: Switching Waveforms



Characteristics Curves

Fig.1 VDS - ID CHARACTERISTICS

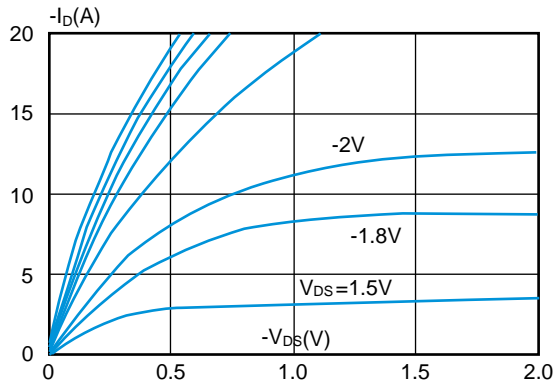

Fig.2 VGS - ID CHARACTERISTICS

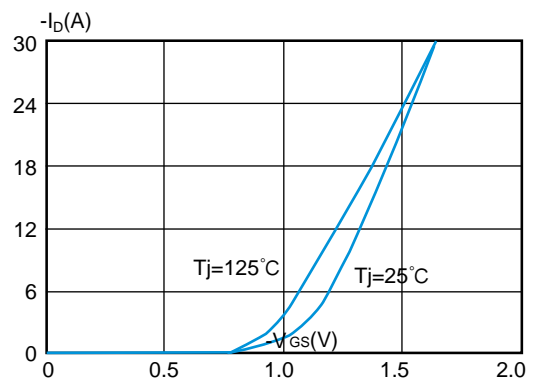

Fig.3 VDS - IS CHARACTERISTICS

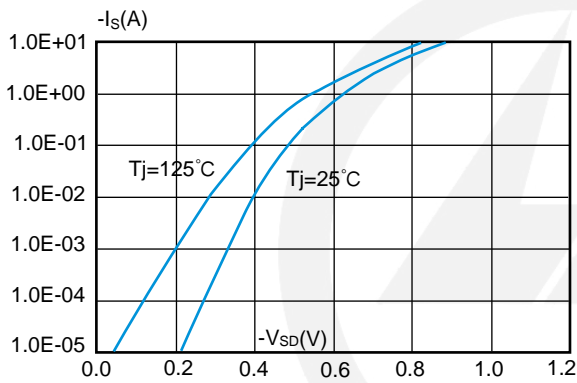

Fig.4 RDS(ON) - ID CHARACTERISTICS

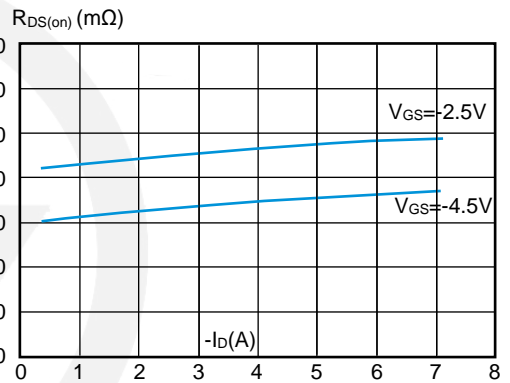

Fig.5 Gate Charge Characteristics

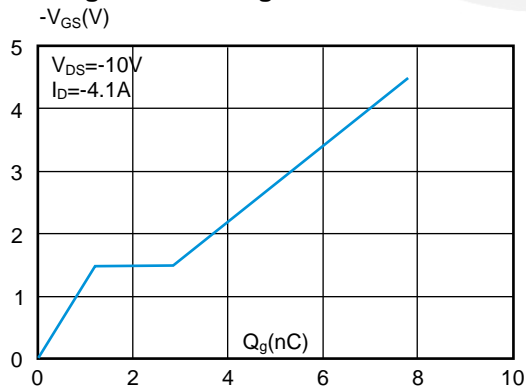
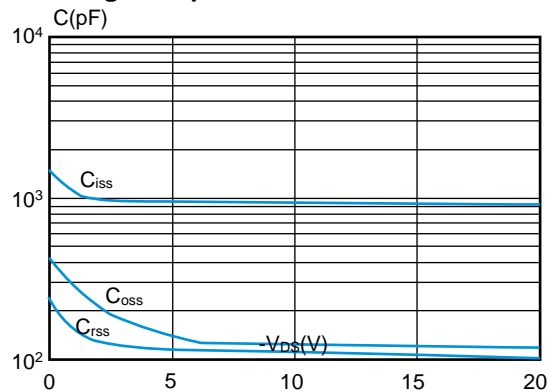
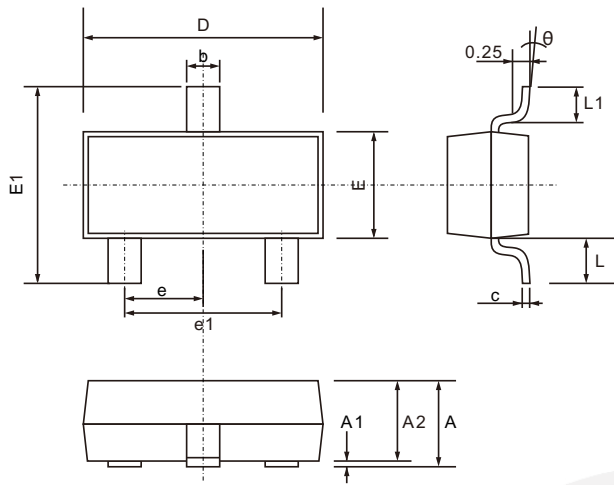

Fig.6 Capacitance Characteristics



SOT-23 Package Outline

Unit: mm



SYMBOL	DIMENSIONS	
	MIN.	MAX.
A	0.900	1.200
A1	0.000	0.100
A2	0.900	1.050
b	0.300	0.500
c	0.080	0.200
D	2.700	3.100
E	1.200	1.400
E1	2.200	2.600
e	0.950 TYP.	
e1	1.750	2.050
L	0.550 TYP.	
L1	0.300	0.500
θ	0°	8°

SOT-23 Suggested Pad Layout

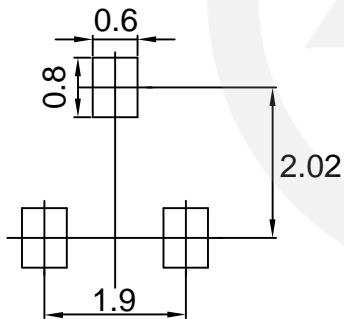

Note:
 1. Controlling dimension: in millimeters.
 2. General tolerance: ± 0.05 mm
 3. The pad layout is for reference purpose only.

Carrier Tape Dimensions

Unit : mm

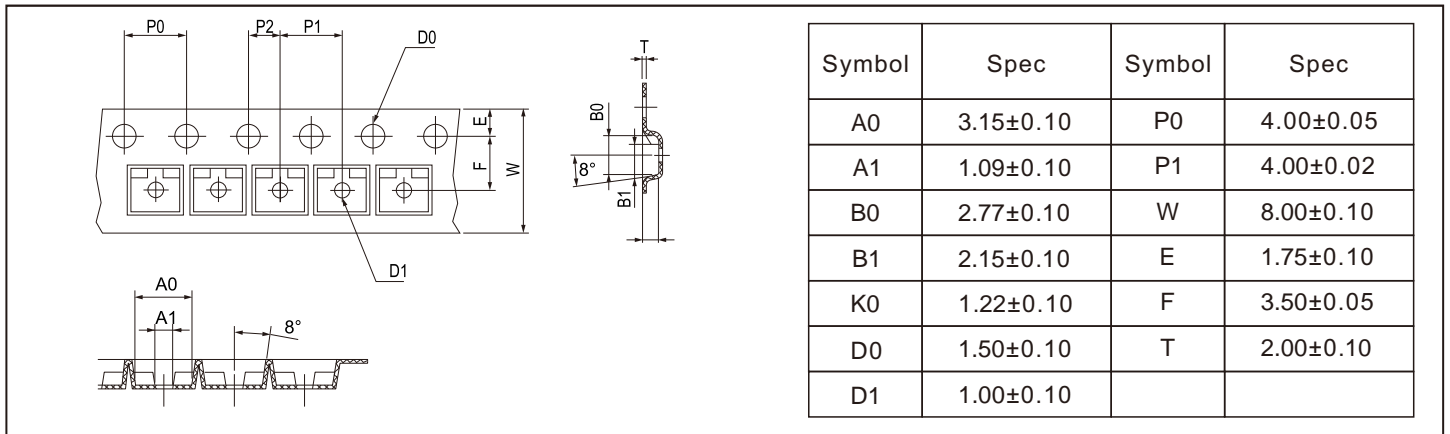

Reel Dimensions

Unit : mm

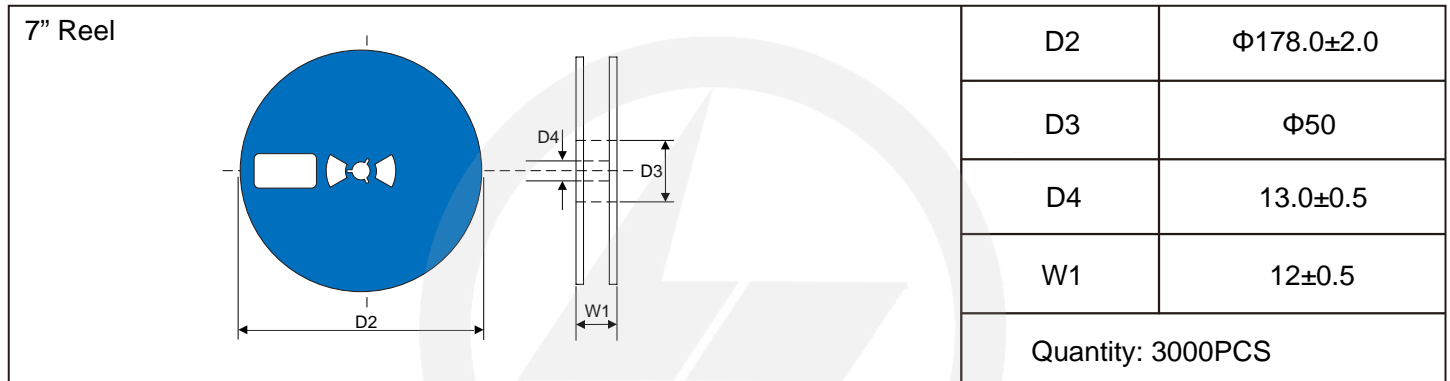

Reel Dimensions

Unit : mm

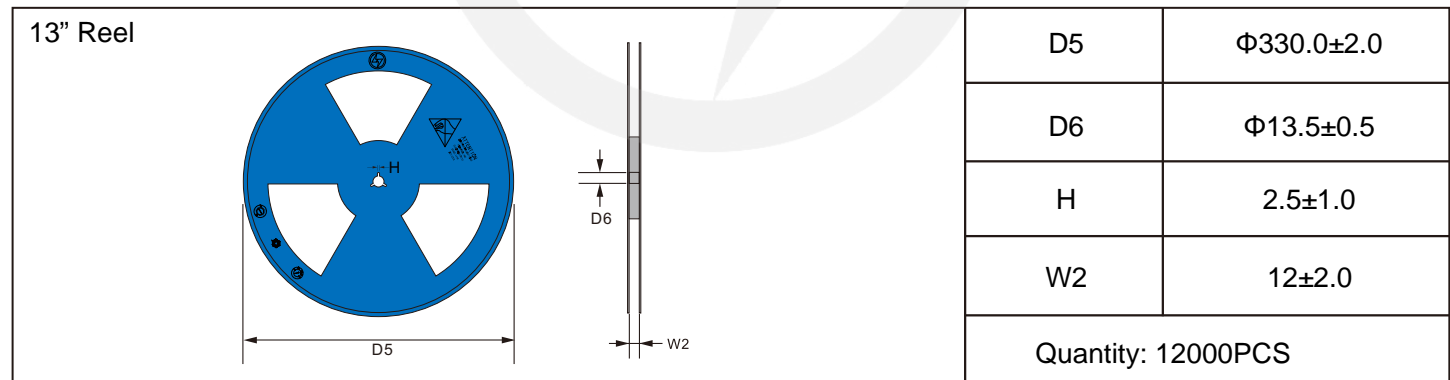

Packaging

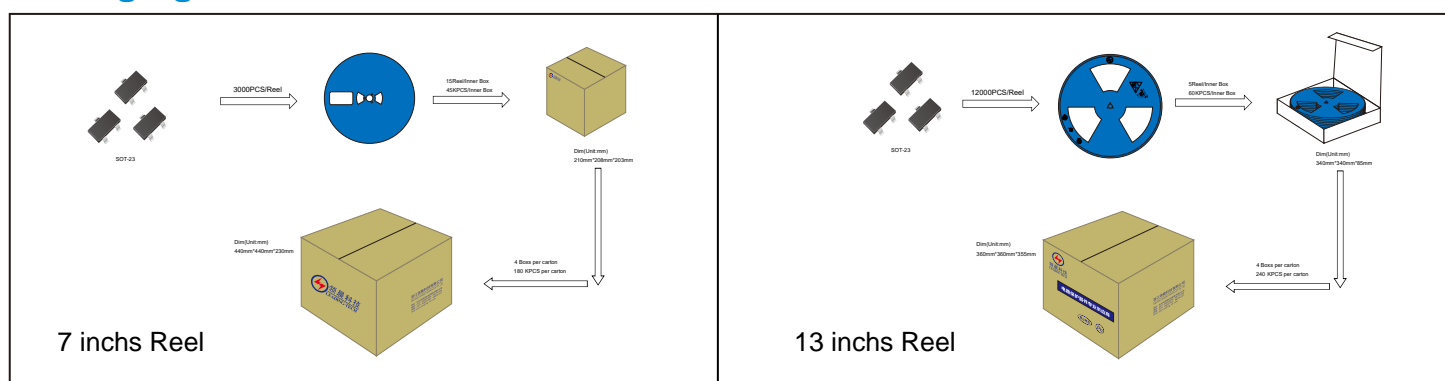



Recommended Soldering Conditions



Recommended Conditions

Profile Feature	Pb-Free Assembly
Average ramp-up rate (T _L to T _P)	3°C/second max.
Preheat	
-Temperature Min (T _{S min})	150°C
-Temperature Max (T _{S max})	200°C
-Time (min to max) (t _s)	60-180 seconds
T _{S max} to T _L	
-Ramp-up Rate	3°C/second max.
Time maintained above:	
-Temperature (T _L)	217°C
-Time (t _L)	60-150 seconds
Peak Temperature (T _P)	260°C
Time within 5°C of actual Peak Temperature (t _p)	20-40 seconds
Ramp-down Rate	6°C/second max.
Time 25°C to Peak Temperature	8 minutes max.

Important Notice and Disclaimer

Leading-Tech reserves the right to make changes to this document and its products and specifications at any time without notice.

Customers should obtain and confirm the latest product information and specifications before final design, purchase or use.

Leading-Tech makes no warranty, representation or guarantee regarding the suitability of its products for any particular purpose, not does Leading-Tech assume any liability for application assistance or customer product design.

Leading-Tech does not warrant or accept any liability with products which are purchase or used for any unintended or unauthorized application.

No license is granted by implication or otherwise under any intellectual property rights of Leading-Tech.

Leading-Tech products are not authorized for use as critical components in life support devices or systems without express written approval of Leading-Tech.

Version Update information

Series NO.	Enactment/Revision Date	Effective Date	Version	Revision Content	Revision Reason	Revision Person	Note
01	2024.03.12	2024.03.12	3.0	New file	/	Ding	
02	2025.05.11	2025.05.11	3.1	Add Moisture Sensitivity Level 3	/	Ding	
03	2026.03.05	2026.03.05	3.2	Package outline E1(max)=2.6mm	/	Ding	