

N-Channel Mosfet

Features

- Epoxy meets UL 94 V-0 flammability rating
- High density cell design for low $R_{DS(ON)}$
- Voltage controlled small signal switch
- Rugged and reliable
- Lead free in comply with EU RoHS 2011/65/EU directives

Mechanical Data

- Case: SOT-23
- Approx. Weight: 8.1mg

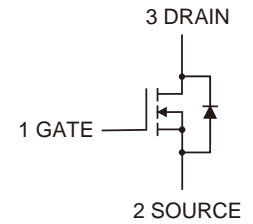
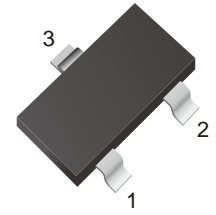

Ordering Information

Part Number	Marking	Shipping	Reel
LTM2300N-TR3	2300	3000PCS Tape&Reel	7 inches
LTM2300N-TR12	2300	12000PCS Tape&Reel	13 inches

Maximum Ratings ($T_a = 25^\circ\text{C}$)

Symbol	Parameter	Value	Unit
V_{DS}	Drain-Source Voltage	20	V
V_{GS}	Gate-Source Voltage	± 12	V
I_D	Drain Current-Continuous	4.5	A
I_{DM}	Pulsed Drain Current ($t_p = 10\mu\text{s}$)	14.4	A
P_D	Power Dissipation	1	W
$R_{\theta JA}$	Thermal Resistance From Junction To Ambient	125	$^\circ\text{C}/\text{W}$
T_j	Junction Temperature	150	$^\circ\text{C}$
T_{stg}	Storage Temperature	-55~+150	$^\circ\text{C}$



Electrical Characteristics (Ta = 25°C)

Symbol	Parameter	Test Conditions	Min	Typ	Max	Units
$V_{(BR)DSS}$	Drain-Source Breakdown Voltage	$V_{GS}=0V, I_D=250\mu A$	20	22		V
$V_{GS(th)}$	Gate-Threshold Voltage	$V_{DS}=V_{GS}, I_D=250\mu A$	0.5	0.75	1.2	V
I_{DSS}	Zero Gate Voltage Drain Current	$V_{DS}=16V, V_{GS}=0V$			1.0	μA
I_{GSS}	Gate-Body Leakage Current	$V_{GS}=\pm 12V, V_{DS}=0V$			± 100	nA
$R_{DS(on)}$	Drain-Source On-Resistance	$V_{GS}=2.5V, I_D=2A$		28	35	m Ω
		$V_{GS}=4.5V, I_D=3A$		22	30	m Ω
g_{FS}	Forward transconductance	$V_{DS}=5V, I_D=3A$		10.5		S
V_{SD}	Diode forward voltage	$I_D=1A, V_{GS}=0V$			1.2	V
Dynamic Characteristics						
C_{iss}	Input Capacitance	$V_{DS}=15V, V_{GS}=0V, f=1MHz$		79	820	pF
C_{oss}	Output Capacitance			118		
C_{rss}	Reverse Transfer Capacitance			85		
Switching Characteristics						
$t_{d(on)}$	Turn-on Delay Time	$V_{GS}=10V, V_{DS}=15V, R_L=2.6\Omega, R_{GEN}=3\Omega$			6.5	nS
t_r	Turn-on rise Time			3.1		
$t_{d(off)}$	Turn-off Delay Time			15.1		
t_f	Turn-off Fall Time			2.7		
Q_g	Total Gate Charge	$V_{DS}=15V, I_D=3A, V_{GS}=4.5V$		4.6		nC
Q_{gS}	Gate-Source Charge			0.7		
Q_{gd}	Gate-Drain("Miller") Charge			1.5		

Characteristics Curves

Fig.1 Output Characteristics

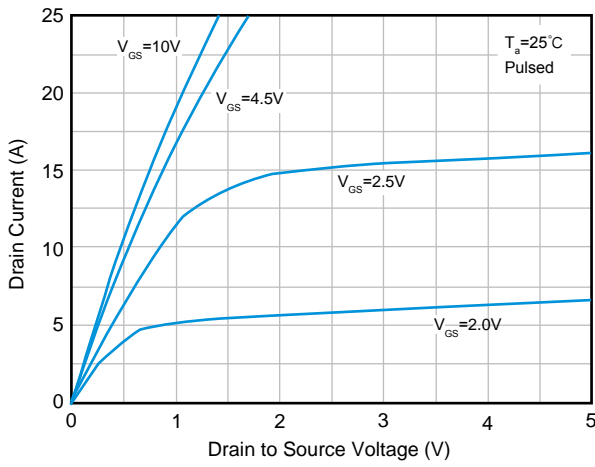

Fig.2 Transfer Characteristics

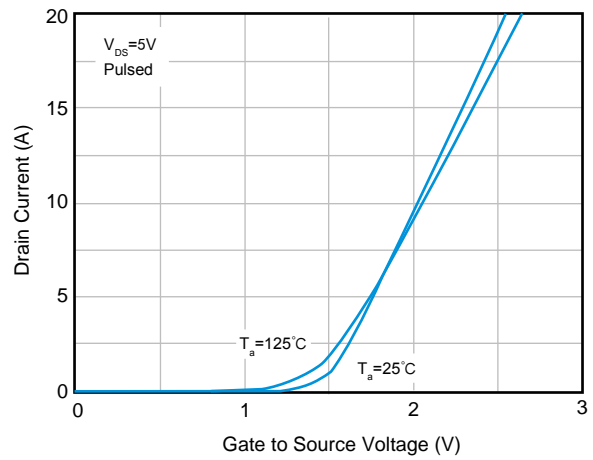

Fig.3 Capacitance Characteristics

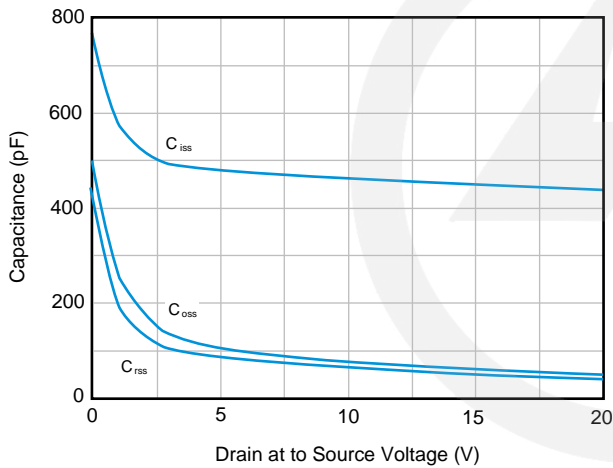

Fig.4 $R_{DS(ON)}$ — Temperature

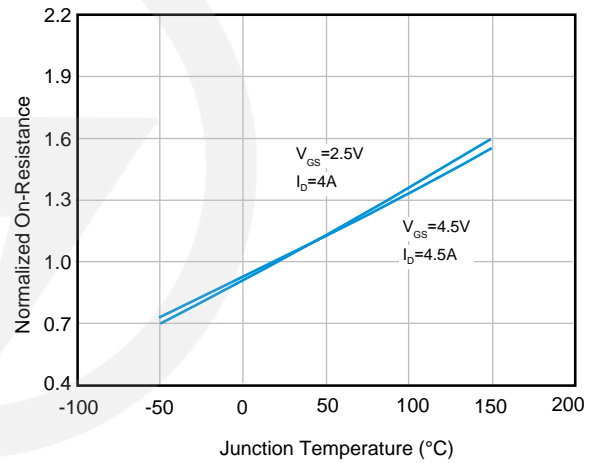

Fig.5 I_S — V_{SD}

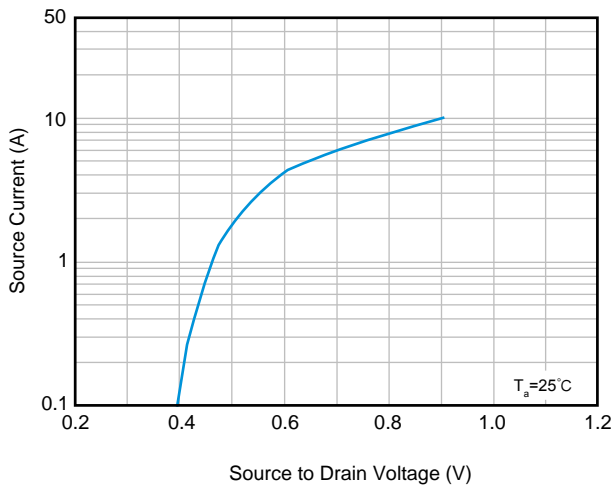
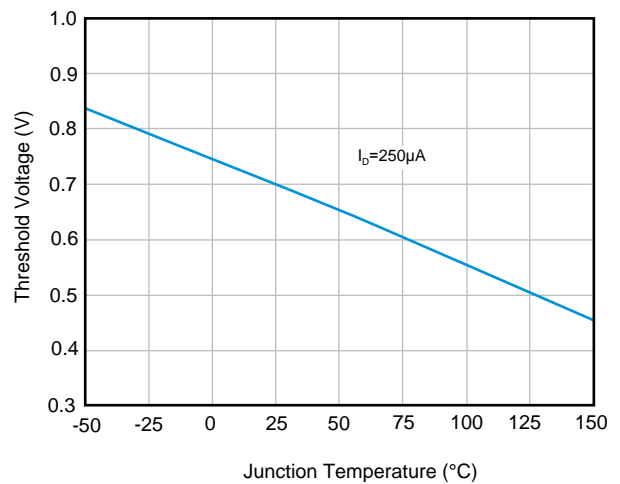
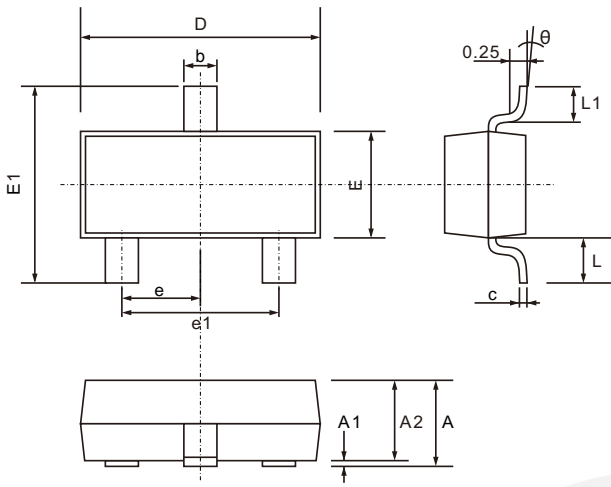

Fig.6 Threshold Voltage



SOT-23 Package Outline

Unit: mm



SYMBOL	DIMENSIONS	
	MIN.	MAX.
A	0.900	1.200
A1	0.000	0.100
A2	0.900	1.050
b	0.300	0.500
c	0.080	0.200
D	2.700	3.100
E	1.200	1.400
E1	2.200	2.600
e	0.950 TYP.	
e1	1.750	2.050
L	0.550 TYP.	
L1	0.300	0.500
θ	0°	8°

SOT-23 Suggested Pad Layout

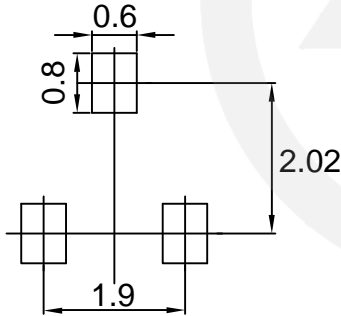

- Note:
1. Controlling dimension: in millimeters.
 2. General tolerance: $\pm 0.05\text{mm}$
 3. The pad layout is for reference purpose only.

Carrier Tape Dimensions

Unit : mm

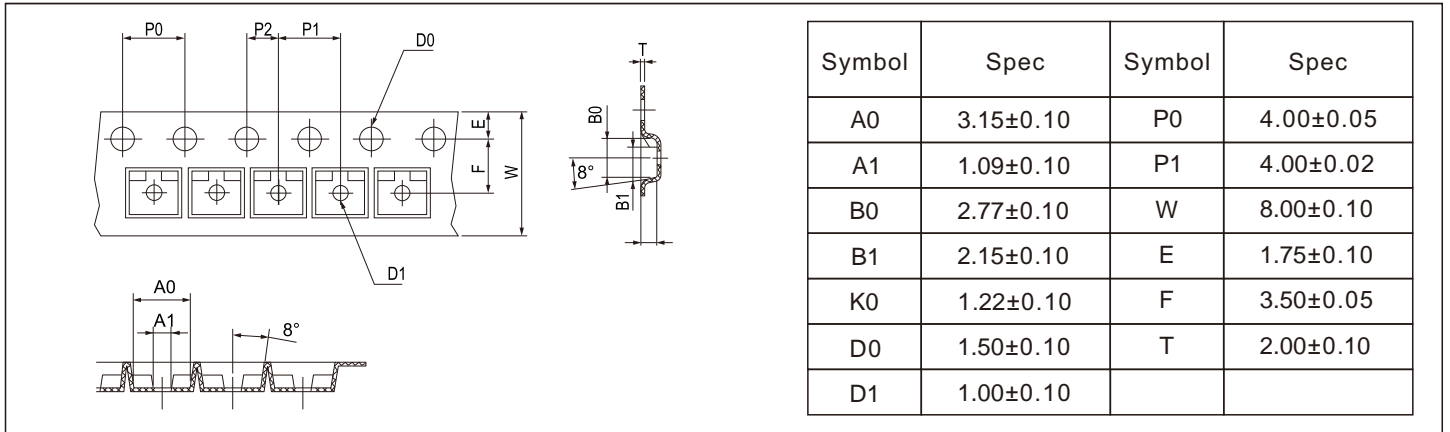

Reel Dimensions

Unit : mm

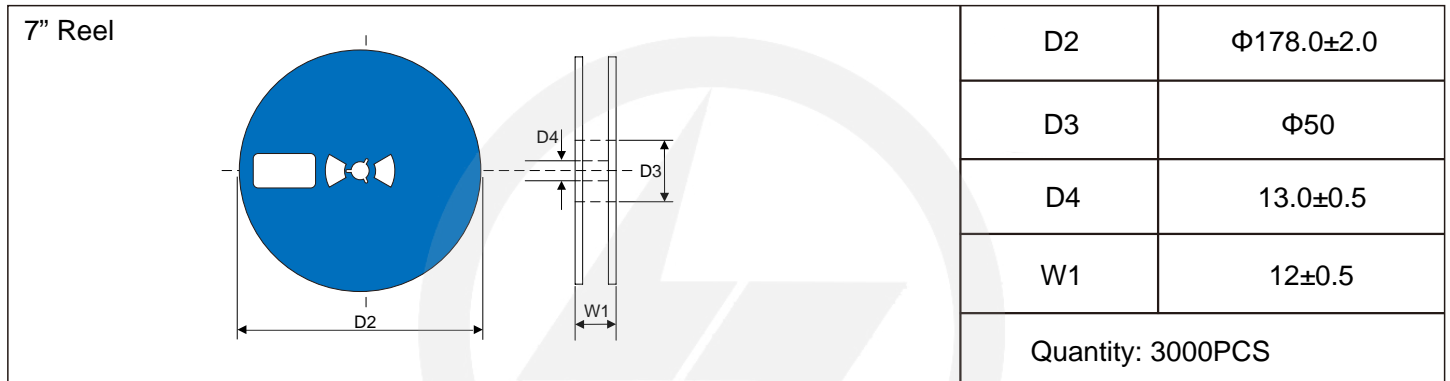

Reel Dimensions

Unit : mm

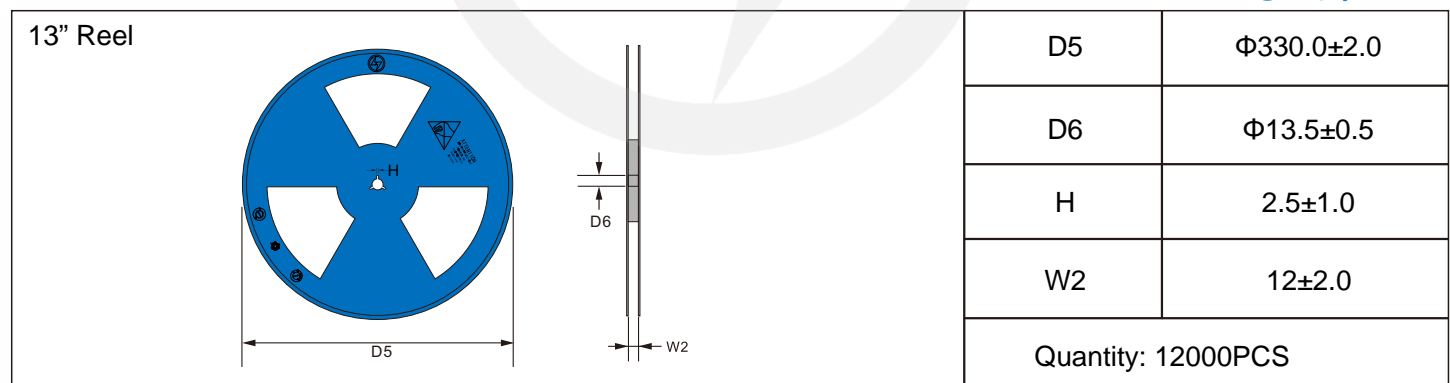

Packaging

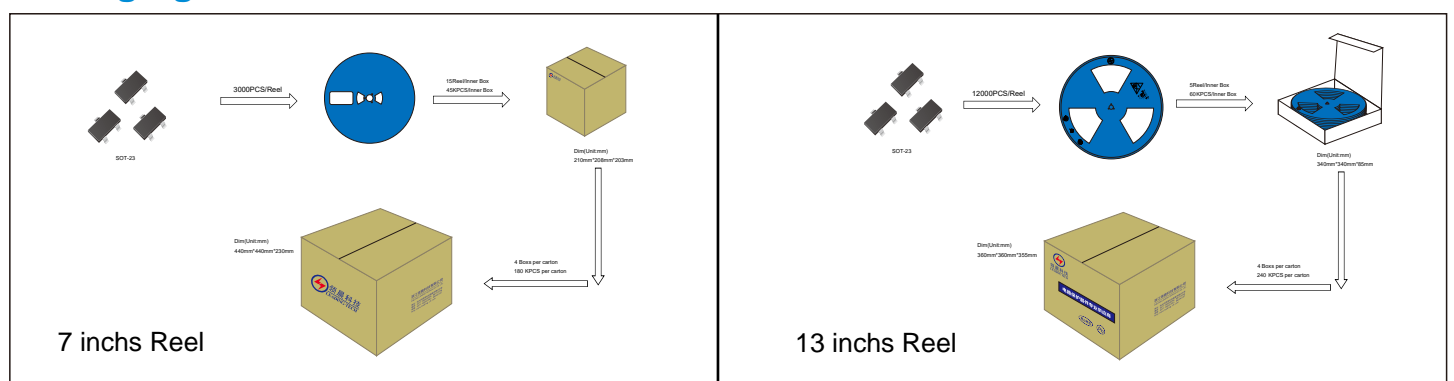



Recommended Soldering Conditions



Recommended Conditions

Profile Feature	Pb-Free Assembly
Average ramp-up rate (T_L to T_P)	3°C/second max.
Preheat	
-Temperature Min ($T_{S\ min}$)	150°C
-Temperature Max ($T_{S\ max}$)	200°C
-Time (min to max) (t_s)	60-180 seconds
$T_{S\ max}$ to T_L	
-Ramp-up Rate	3°C/second max.
Time maintained above:	
-Temperature (T_L)	217°C
-Time (t_L)	60-150 seconds
Peak Temperature (T_P)	260°C
Time within 5°C of actual Peak Temperature (t_p)	20-40 seconds
Ramp-down Rate	6°C/second max.
Time 25°C to Peak Temperature	8 minutes max.

Important Notice and Disclaimer

Leading-Tech reverses the right to make changes to this document and its products and specifications at any time without notice.

Customers should obtain and confirm the latest product information and specifications before final design, purchase or use.

Leading-Tech makes no warranty, representation or guarantee regarding the suitability of its products for any particular purpose, not does Leading-Tech assume any liability for application assistance or customer product design.

Leading-Tech does not warrant or accept any liability with products which are purchase or used for any unintended or unauthorized application.

No license is granted by implication or otherwise under any intellectual property rights of Leading-Tech.

Leading-Tech products are not authorized for use as critical components in life support devices or systems without express written approval of Leading-Tech.

Version Update Information

Series NO.	Enactment/Revision Date	Effective Date	Version	Revision Content	Revision Reason	Revision Person	Note
01	2024.12.03	2024.12.03	3.0	New file	/	Ding	
02	2026.03.04	2026.03.04	3.1	Package outline E1(max)=2.6mm	/	Ding	