

## Schottky Barrier Rectifiers

### Features

- High current capability
- Low forward voltage drop
- Low power loss, high efficiency
- High surge capability
- High temperature soldering guaranteed
- Mounting position: any
- Lead free in comply with EU RoHS 2011/65/EU directives

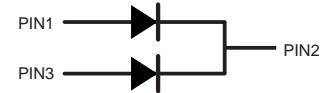
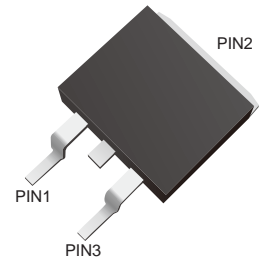

### Ordering Information

Part Number	Shipping	Reel
LTM2040GT THRU LTM20200GT-TR0.8K	800PCS Tape&Reel	13 inches

### Maximum Ratings and Electrical Characteristics ( Ta=25 unless otherwise noted )

Characteristics	Symbol	LTM2040GT	LTM2045GT	LTM2060GT	LTM20100GT	LTM20150GT	LTM20200GT	Units
Maximum Recurrent Peak Reverse Voltage	$V_{RRM}$	40	45	60	100	150	200	V
Maximum RMS voltage	$V_{RMS}$	28	32	42	70	105	140	V
Maximum DC Blocking Voltage	$V_{DC}$	40	45	60	100	150	200	V
Maximum Average Forward Rectified Current per diode per device	$I_{F(AV)}$	10 20						A
Peak Forward Surge Current, 8.3ms Single Half Sine-wave Superimposed on Rated Load (JEDEC method) per diode	$I_{FSM}$	150						A
Max Instantaneous Forward Voltage at 10 A DC Per leg	$V_F$	0.70		0.75	0.85	0.90	0.92	V
Maximum DC Reverse Current at Rated DC Reverse Voltage $T_a = 25^{\circ}C$ $T_a = 125^{\circ}C$	$I_R$	0.1 20			0.05 20			mA
Typical Junction Capacitance <sup>(1)</sup>	$C_j$	600		400				pF
Typical Thermal Resistance <sup>(2)</sup>	$R_{\theta,JA}$	45						$^{\circ}C/W$
Operating Junction Temperature Range	$T_j$	-55 ~ +150				-55 ~ +175		$^{\circ}C$
Storage Temperature Range	$T_{stg}$	-55 ~ +150				-55 ~ +175		$^{\circ}C$

(1) Measured at 1 MHz and applied reverse voltage of 4 V D.C

(2) P.C.B. mounted with 10cmX10cmX1mm copper pad areas.



Characteristics Curves

Fig.1 Typical Forward Current Derating Curve

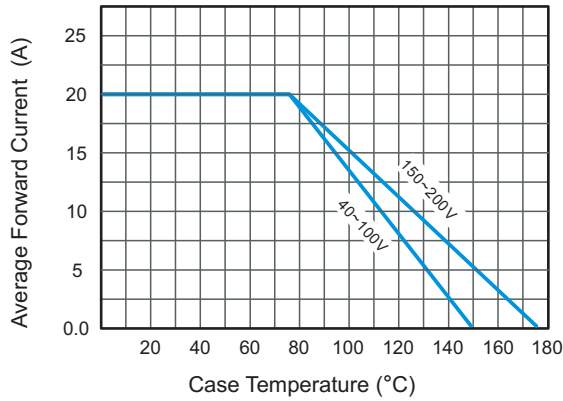

Fig.2 Typical Reverse Characteristics

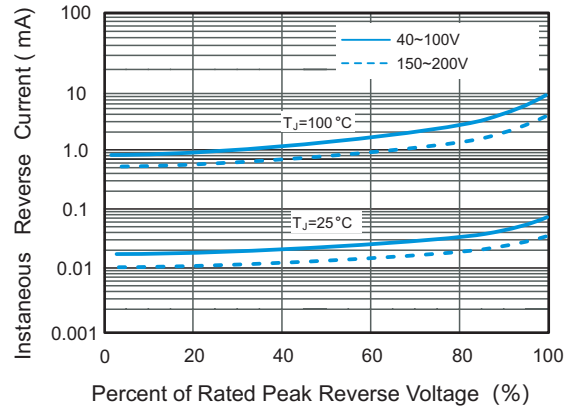

Fig.3 Typical Forward Characteristic(per leg)

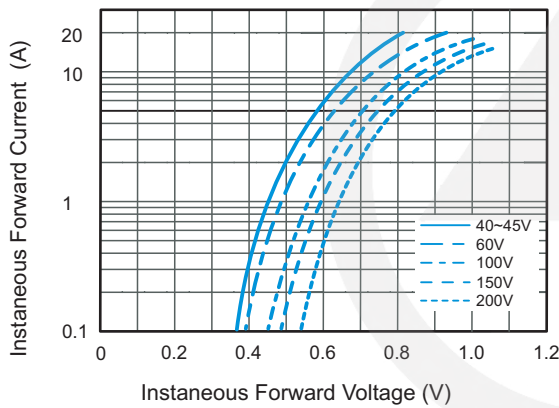

Fig.4 Typical Junction Capacitance

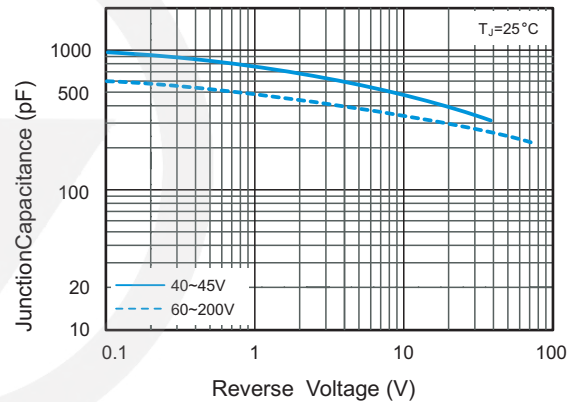

Fig.5 Maximum Non-Repetitive Peak Forward Surge Current

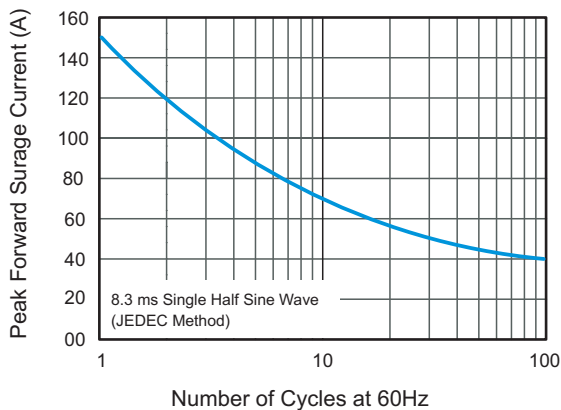
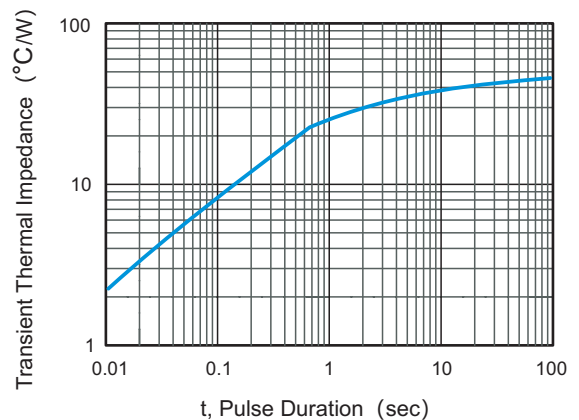
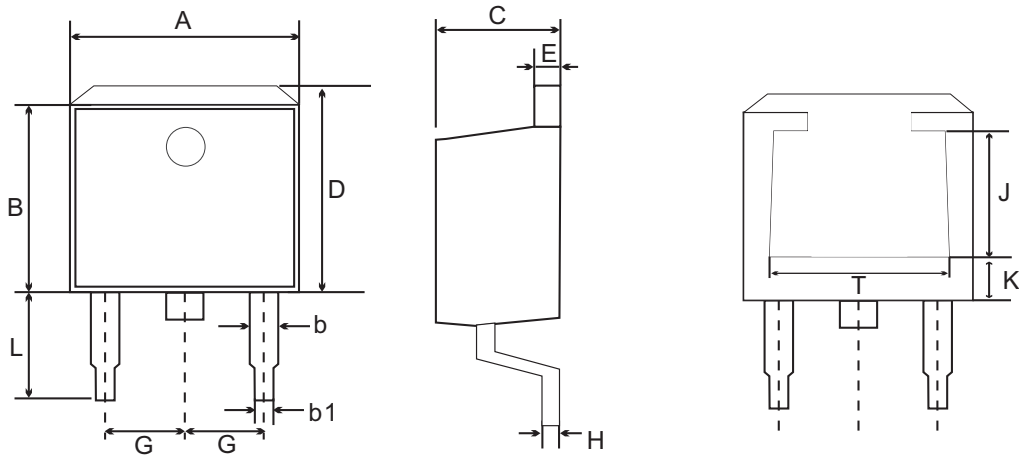

Fig.6 Typical Transient Thermal Impedance



## TO-263 Package Outline



UNIT		A	B	b	b1	C	D	E	G	H	L	J	T	K
mm	max	10.4	9.1	1.5	0.91	4.8	10.6	1.40	2.75	0.7	6.0	4.65 ref.	7.70 ref.	3.22 ref.
	min	9.8	8.4	1.0		4.4	9.6	1.20	2.35	0.3	5.0			

### Marking

Type number	Marking code
LTM2040GT	MBR2040GT
LTM2045GT	MBR2045GT
LTM2060GT	MBR2060GT
LTM20100GT	MBR20100GT
LTM20150GT	MBR20150GT
LTM20200GT	MBR20200GT

## Reel Dimensions

Unit : mm

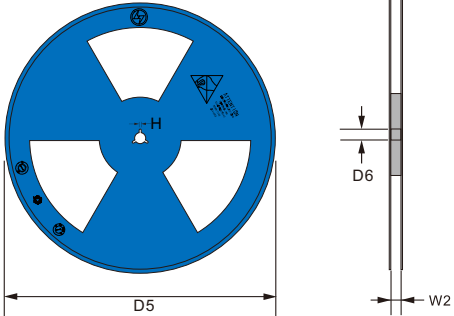
<p>13" Reel</p> 	D5	$\Phi 330.0 \pm 2.0$
	D6	$\Phi 13.5 \pm 0.5$
	H	$2.5 \pm 1.0$
	W2	$25.2 \pm 2.0$
	Quantity: 800PCS	

## Packaging

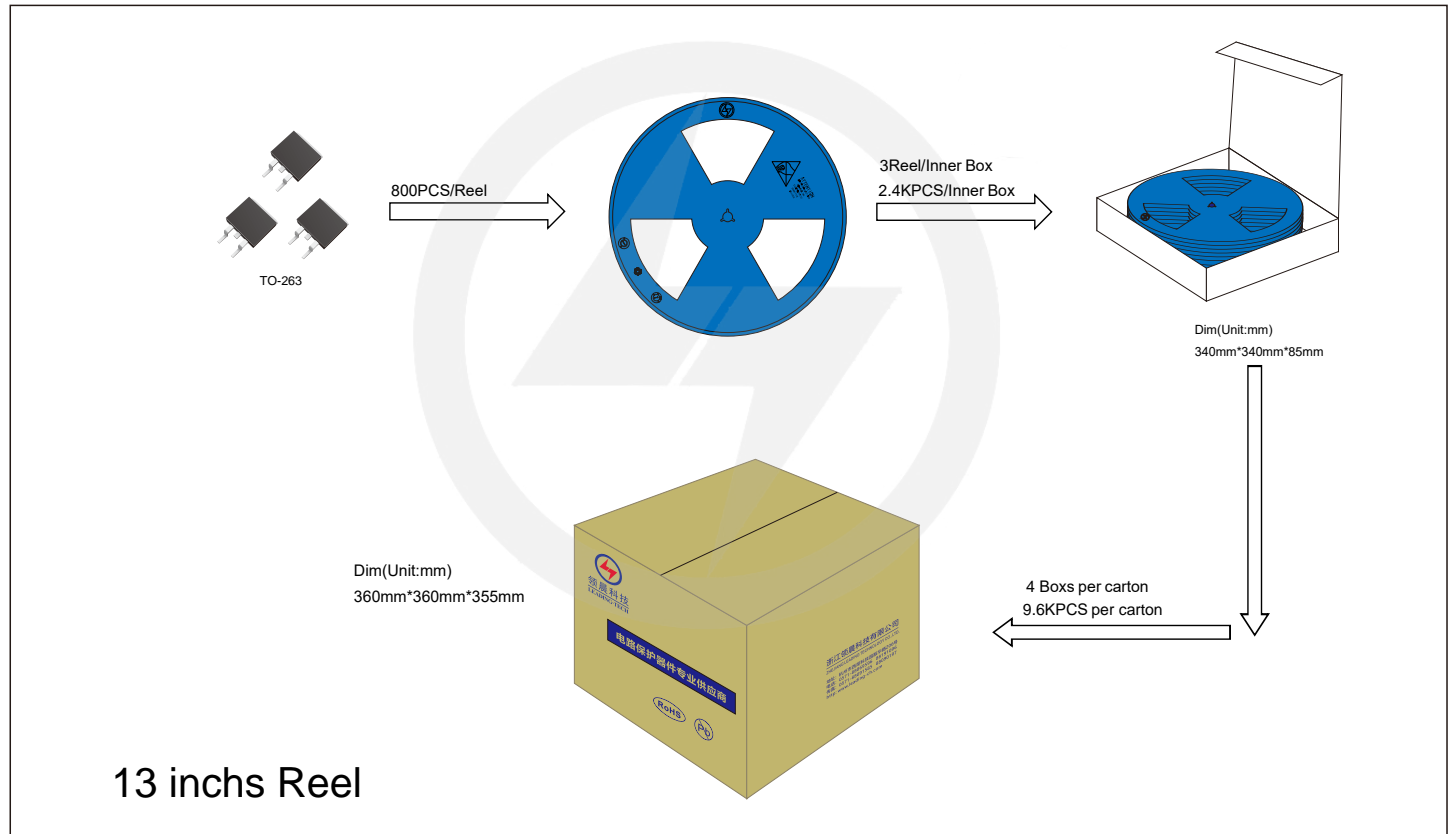



Recommended Soldering Conditions

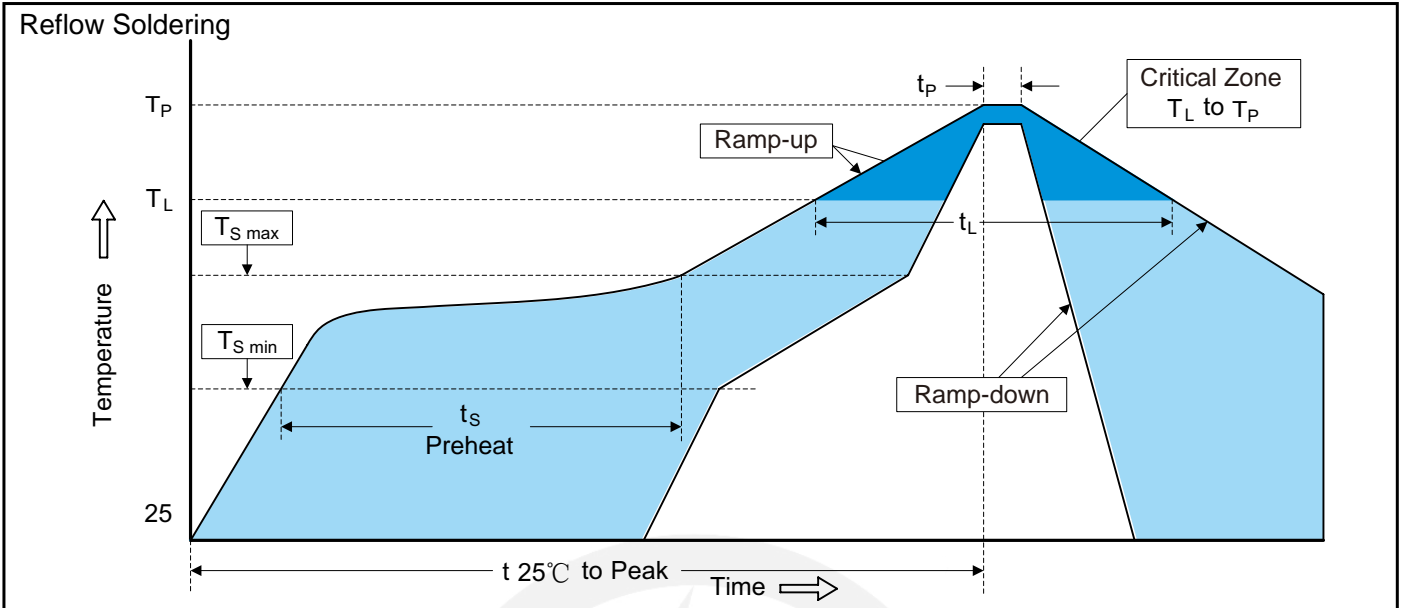

Recommended Conditions

Profile Feature	Pb-Free Assembly
Average ramp-up rate (T <sub>L</sub> to T <sub>P</sub> )	3°C/second max.
Preheat	
-Temperature Min (T <sub>S min</sub> )	150°C
-Temperature Max (T <sub>S max</sub> )	200°C
-Time (min to max) (t <sub>s</sub> )	60-180 seconds
T <sub>S max</sub> to T <sub>L</sub>	
-Ramp-up Rate	3°C/second max.
Time maintained above:	
-Temperature (T <sub>L</sub> )	217°C
-Time (t <sub>L</sub> )	60-150 seconds
Peak Temperature (T <sub>P</sub> )	260°C
Time within 5°C of actual Peak Temperature (t <sub>p</sub> )	20-40 seconds
Ramp-down Rate	6°C/second max.
Time 25°C to Peak Temperature	8 minutes max.

## Important Notice and Disclaimer

Leading-Tech reserves the right to make changes to this document and its products and specifications at any time without notice.

Customers should obtain and confirm the latest product information and specifications before final design, purchase or use.

Leading-Tech makes no warranty, representation or guarantee regarding the suitability of its products for any particular purpose, not does Leading-Tech assume any liability for application assistance or customer product design.

Leading-tech does not warrant or accept any liability with products which are purchase or used for any unintended or unauthorized application.

No license is granted by implication or otherwise under any intellectual property rights of Leading-Tech.

Leading-Tech products are not authorized for use as critical components in life support devices or systems without express written approval of Leading-tech.

## Version Update Information

Series NO.	Enactment/Revision Date	Effective Date	Version	Revision content	Revision Reason	Revision Person	Note
01	2024.12.26	2024.12.26	3.0	New File	/	Ding	