

N-Channel Mosfet

Features

- Low Gate Threshold Voltage
- Low Input Capacitance
- Fast Switching Speed
- Low Input/Output Leakage
- High Drain-Source Voltage Rating
- Lead free in comply with EU RoHS 2011/65/EU directives

Mechanical Data

- Case:SOT-23
- Approx. Weight: 8.1mg

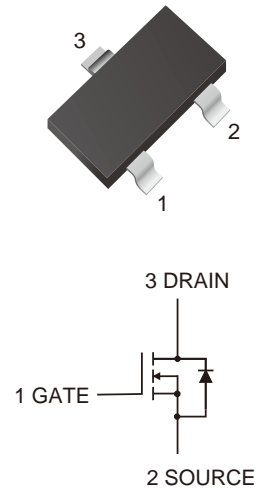

Ordering Information

Part Number	Marking	Shipping	Reel
LTM123N-TR3	SA	3000PCS Tape&Reel	7 inches
LTM123N-TR12	SA	12000PCS Tape&Reel	13 inches

Absolute Maximum Ratings(Ta=25°C)

Symbol	Parameter	Value	Unit
V _{DS}	Drain-Source Voltage	100	V
V _{GS}	Gate-Source Voltage	±20	V
I _D	Continuous Drain Current	0.17	A
I _{DM}	Pulsed Drain Current (tp=10s)	0.68	A
P _D	Power Dissipation	300	mW
R _{θJA}	Thermal Resistance From Junction To Ambient (t≤5s)	350	°C/W
T _J , T _{stg}	Operation Junction And Storage Temperature Range	-55 to +150	°C



Electrical Characteristics (Ta=25°C unless otherwise specified)

Symbol	Parameter	Test conditions	Min	Typ	Max	Unit
Static						
$V_{(BR)DSS}$	Drain-source breakdown voltage	$V_{GS}=0, I_D=250\mu A$	100			V
$V_{GS(th)}$	Gate threshold voltage	$V_{DS}=V_{GS}, I_D=250\mu A$	0.8		2.0	V
I_{GSS}	Gate-body leakage current	$V_{DS}=0, V_{GS}=\pm 20V$			± 100	nA
I_{DSS}	Zero gate voltage drain current	$V_{DS}=100V, V_{GS}=0V$			1	μA
$R_{DS(on)}$	Drain-source on-resistance ^a	$V_{GS}=10V, I_D=0.17A$	1.0	2.8	5.0	Ω
		$V_{GS}=4.5V, I_D=0.17A$	1.2	3.0	8.0	Ω
g_{FS}	Forward transconductance ^a	$V_{DS}=10V, I_D=-0.17A$	80			mS
V_{SD}	Diode forward voltage	$I_S=0.34A, V_{GS}=0V$			1.0	V
Dynamic						
C_{iss}	Input capacitance	$V_{DS}=25V, V_{GS}=0V, f=1MHz$		42.7		pF
C_{oss}	Output capacitance			14		
C_{rss}	Reverse transfer capacitance ^b			3		
Switching^b						
$t_{d(on)}$	Turn-on delay time	$V_{GS}=10V, V_{DS}=30V$ $I_D=280mA, R_{GEN}=50\Omega,$ $R_L=107\Omega$		5.5		nS
t_r	Rise time			22		
$t_{d(off)}$	Turn-off delay time			5.3		
t_f	Fall time			6.4		

Notes :

a. Pulse Test : Pulse width $\leq 300\mu s$, duty cycle $\leq 2\%$.

b. Guaranteed by design, not subject to producing.

Characteristics Curve

Fig.1 I_D vs V_{DS}

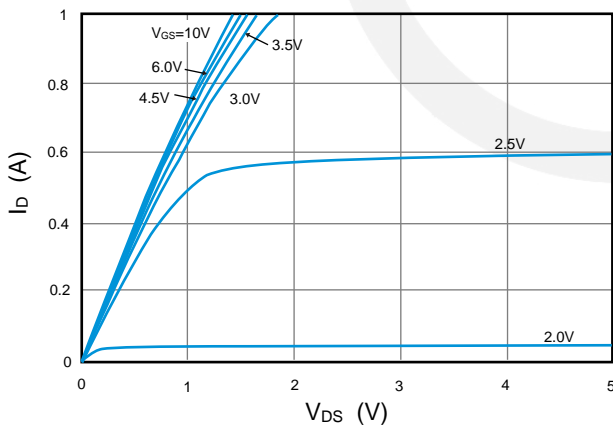

Fig.2 $R_{DS(on)}$ vs I_D

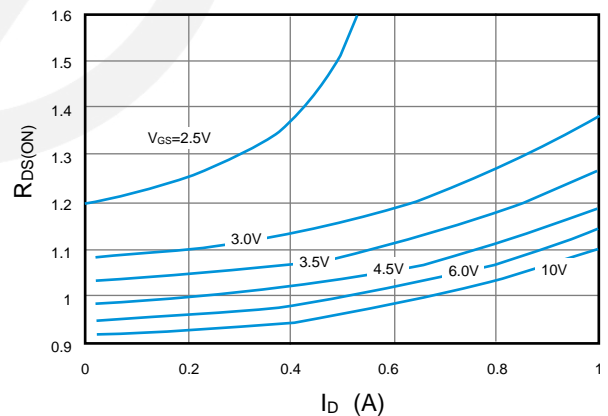

Fig.3 $R_{DS(on)}$ vs T_J

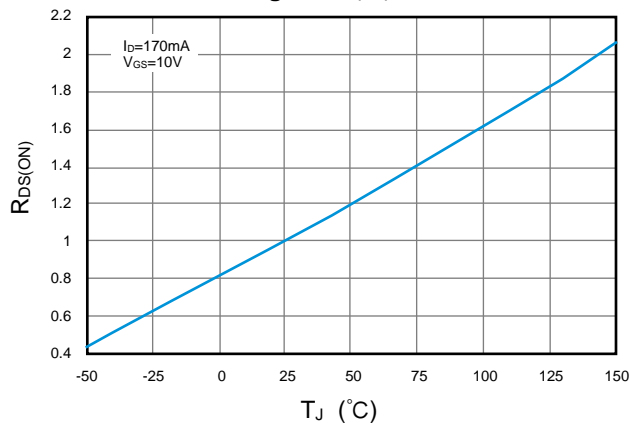

Fig.4 $R_{DS(on)}$ vs V_{GS}

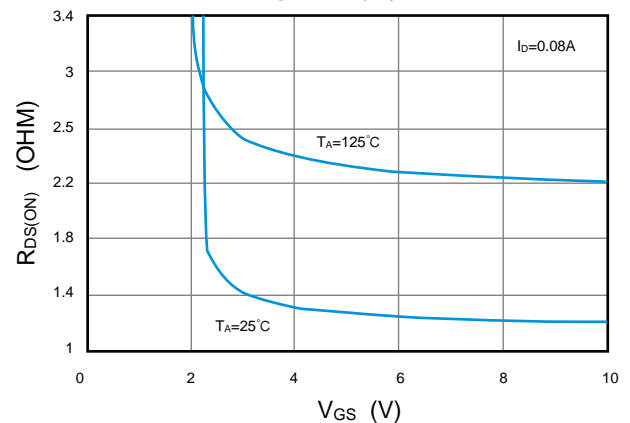



Fig.5 I_D vs V_{GS}

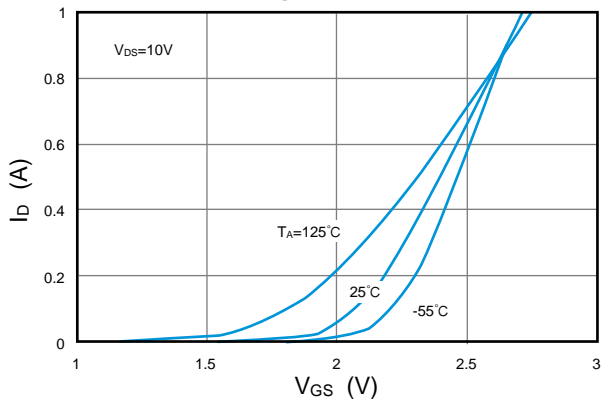

Fig.6

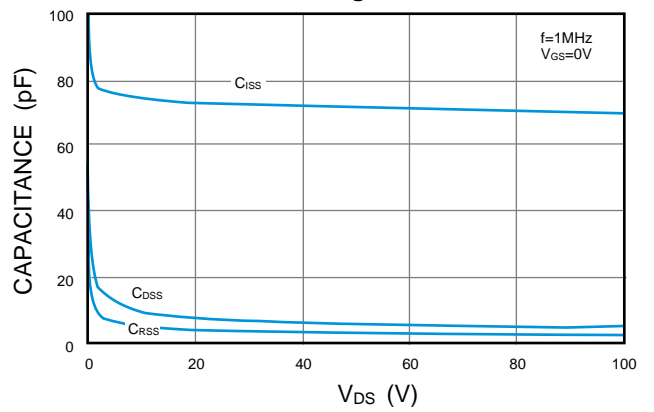

Fig.7 I_D vs V_{DS}

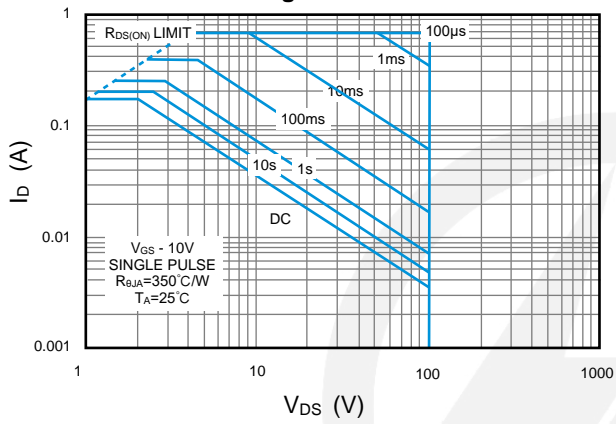
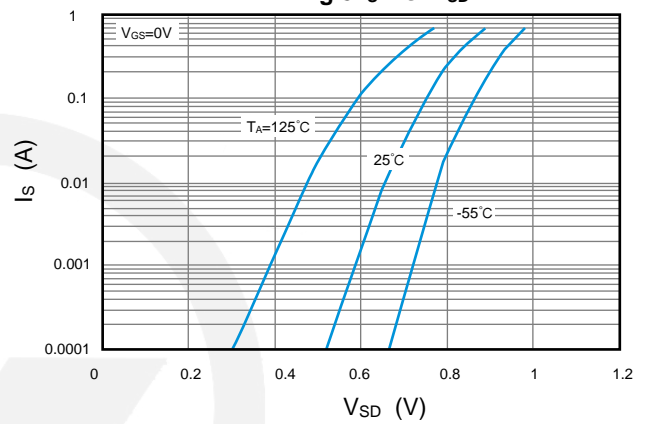
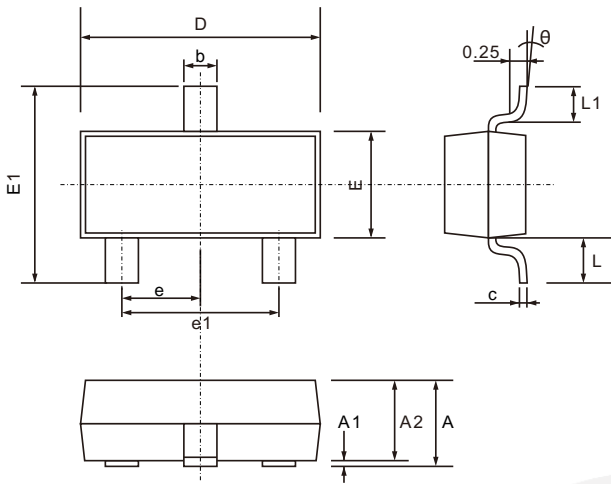

Fig.8 I_S vs V_{SD}



SOT-23 Package Outline

Unit: mm



SYMBOL	DIMENSIONS	
	MIN.	MAX.
A	0.900	1.200
A1	0.000	0.100
A2	0.900	1.050
b	0.300	0.500
c	0.080	0.200
D	2.700	3.100
E	1.200	1.400
E1	2.200	2.600
e	0.950 TYP.	
e1	1.750	2.050
L	0.550 TYP.	
L1	0.300	0.500
θ	0°	8°

SOT-23 Suggested Pad Layout

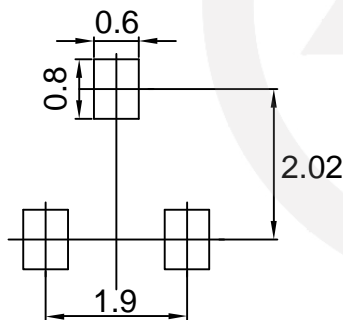

Note:
 1. Controlling dimension: in millimeters.
 2. General tolerance: $\pm 0.05\text{mm}$
 3. The pad layout is for reference purpose only.

Carrier Tape Dimensions

Unit : mm

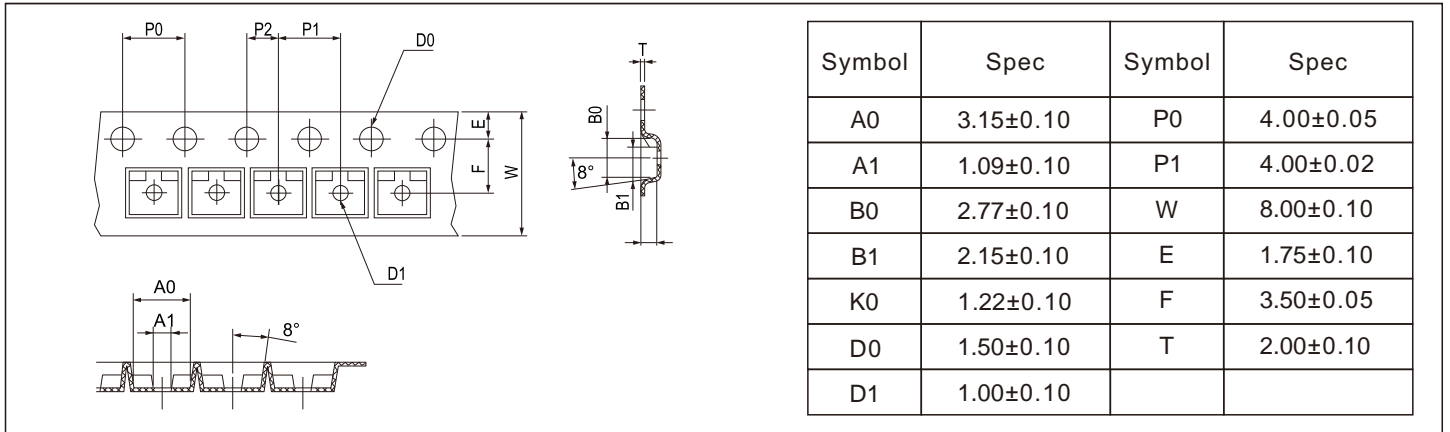

Reel Dimensions

Unit : mm

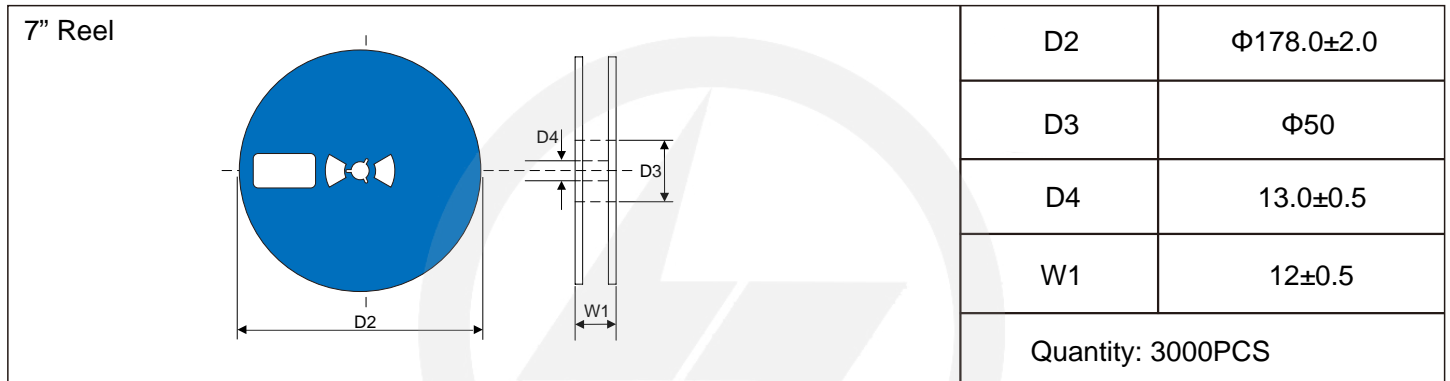

Reel Dimensions

Unit : mm

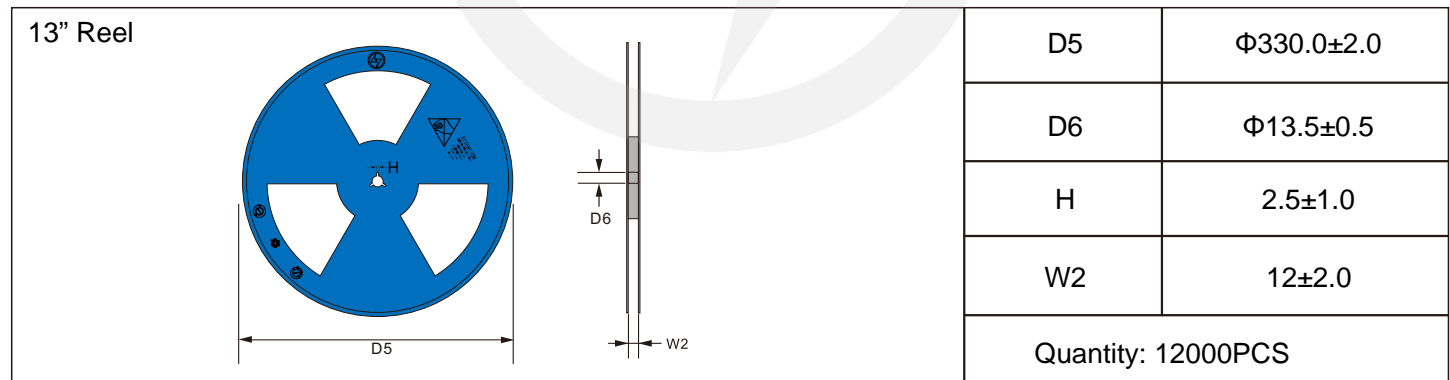

Packaging

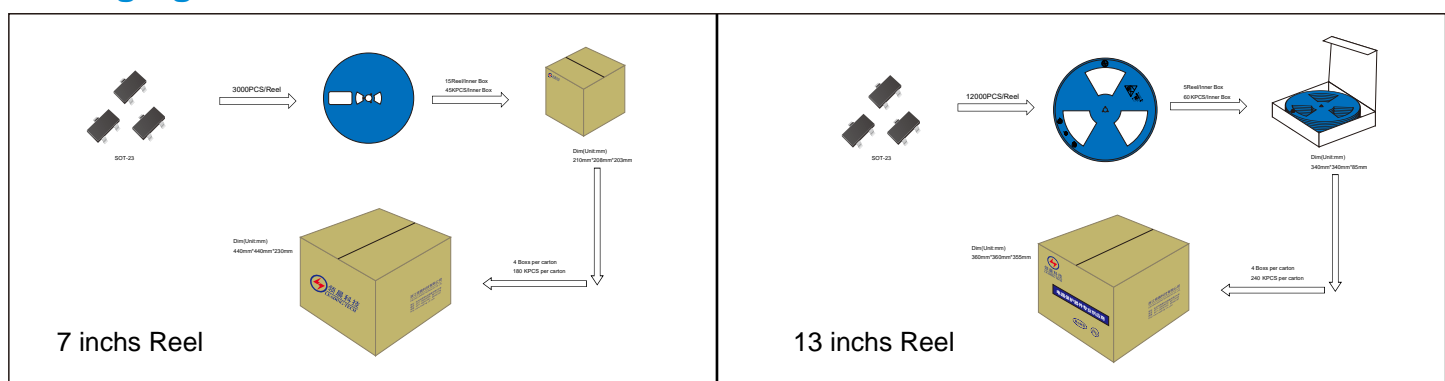



Recommended Soldering Conditions

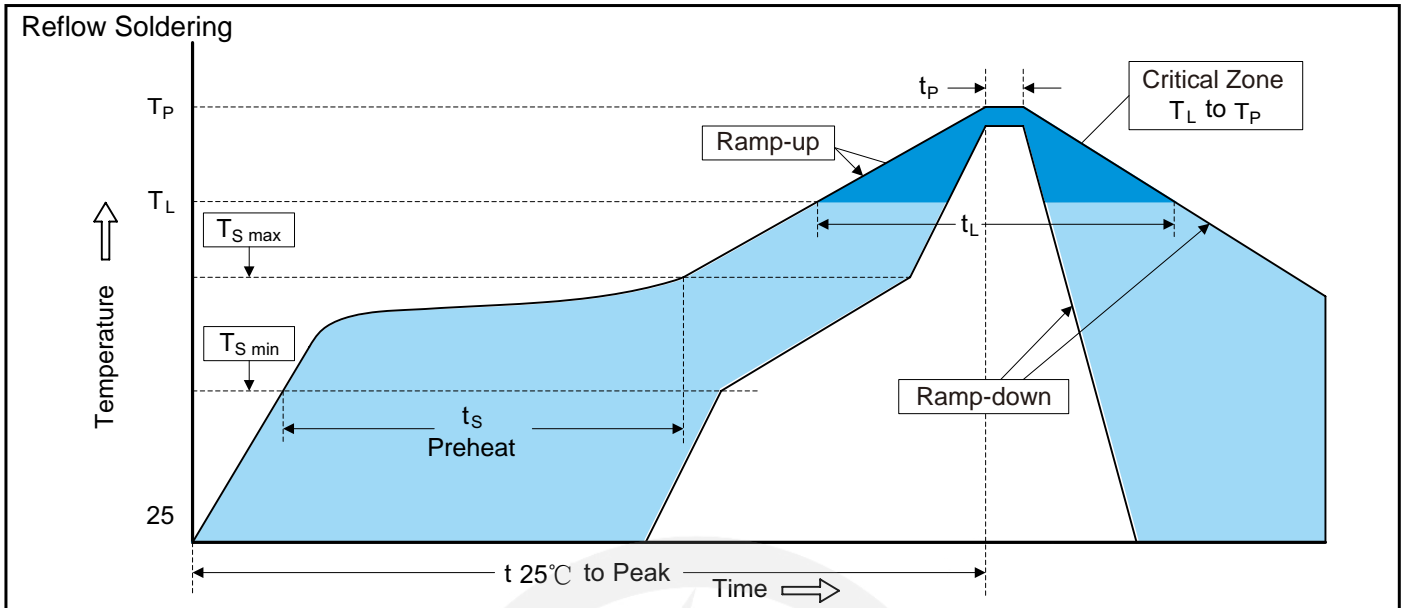

Recommended Conditions

Profile Feature	Pb-Free Assembly
Average ramp-up rate (T _L to T _P)	3°C/second max.
Preheat	
-Temperature Min (T _{S min})	150°C
-Temperature Max (T _{S max})	200°C
-Time (min to max) (t _s)	60-180 seconds
T _{S max} to T _L	
-Ramp-up Rate	3°C/second max.
Time maintained above:	
-Temperature (T _L)	217°C
-Time (t _L)	60-150 seconds
Peak Temperature (T _P)	260°C
Time within 5°C of actual Peak Temperature (t _p)	20-40 seconds
Ramp-down Rate	6°C/second max.
Time 25°C to Peak Temperature	8 minutes max.

Important Notice and Disclaimer

Leading-Tech reverses the right to make changes to this document and its products and specifications at any time without notice.

Customers should obtain and confirm the latest product information and specifications before final design, purchase or use.

Leading-Tech makes no warranty, representation or guarantee regarding the suitability of its products for any particular purpose, not does Leading-Tech assume any liability for application assistance or customer product design.

Leading-Tech does not warrant or accept any liability with products which are purchase or used for any unintended or unauthorized application.

No license is granted by implication or otherwise under any intellectual property rights of Leading-Tech.

Leading-Tech products are not authorized for use as critical components in life support devices or systems without express written approval of Leading-Tech.

Version Update Information

Series NO.	Enactment/Revision Date	Effective Date	Version	Revision Content	Revision Reason	Revision Person	Note
01	2024.03.20	2024.03.20	3.0	New file	/	Ding	
02	2025.06.12	2025.06.12	3.1	Update packaging information	/	Ding	
03	2025.06.12	2025.06.12	3.2	Optimize parameters	/	Ding	
04	2026.03.04	2026.03.04	3.3	Package outline E1(max)=2.6mm	/	Ding	