

## Switching Diodes

### Features

- Fast Switching Speed
- Surface mount package ideally Suited for Automatic Insertio
- High Conductance
- Lead free in comply with EU RoHS 2011/65/EU directives
- Moisture Sensitivity Level 1
- ESD:2000V(HBM)

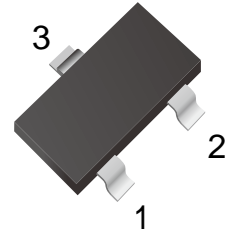
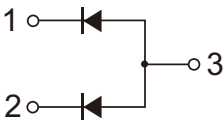
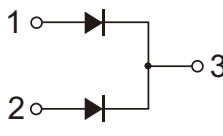
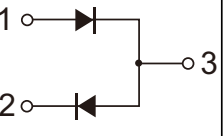

LTKT23A7	LTKT23C6	LTKL23S31
		
MARKING:KT7	MARKING:KT6	MARKING:KL31

### Ordering Information

Part Number	Shipping	Reel
LTKT23A7 / LTKT23C6/ LTKL23S31-TR3	3000PCS Tape&Reel	7 inches
LTKT23A7 / LTKT23C6/ LTKL23S31-TR12	12000PCS Tape&Reel	13 inches

### Maximum Ratings( @Ta=25°C )

Parameter	Symbol	Value	Unit
Repetitive peak reverse voltage	V <sub>RRM</sub>	250	V
Average rectified output current	I <sub>O</sub>	200	mA
Non-Repetitive Peak Forward Surge Current @t=8.3ms	I <sub>FSM</sub>	1.0	A
Power dissipation	P <sub>D</sub>	350	mW
Thermal resistance junction to ambient	R <sub>thJA</sub>	357	°C/W
Junction temperature	T <sub>J</sub>	150	°C
Storage temperature range	T <sub>STG</sub>	-55 ~ +150	°C

### Electrical characteristics ( @Ta=25°C )

Parameter	Symbol	Test conditions	Min	Typ	Max	Unit
Reverse breakdown voltage	V <sub>BR</sub>	I <sub>R</sub> =100μA	250			V
Reverse voltage leakage current	I <sub>R</sub>	V <sub>R</sub> =200V			0.1	μA
Forward voltage	V <sub>F</sub>	I <sub>F</sub> =100mA I <sub>F</sub> =200mA			1.0 1.25	V
Diode capacitance	C <sub>D</sub>	V <sub>R</sub> =0V, f=1MHz		5		pF
Reveres recovery time	t <sub>rr</sub>	I <sub>F</sub> =I <sub>R</sub> =30mA, V <sub>R</sub> =6V I <sub>rr</sub> =3mA, R <sub>L</sub> =100Ω			50	ns



### Characteristics Curves

Fig.1 Power Derating Curve

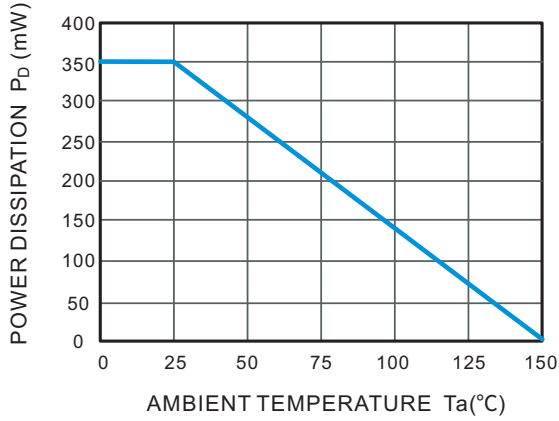

Fig.2 Reverse Characteristics

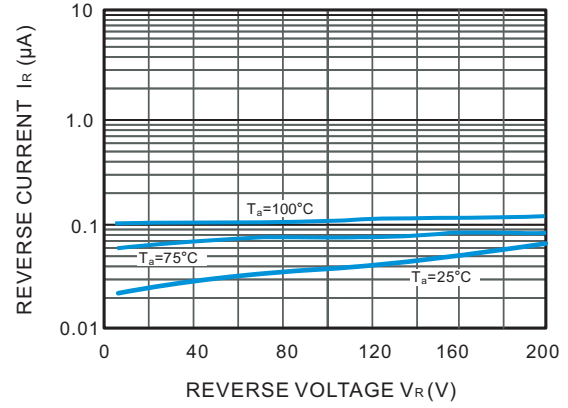

Fig.3 Forward Characteristics

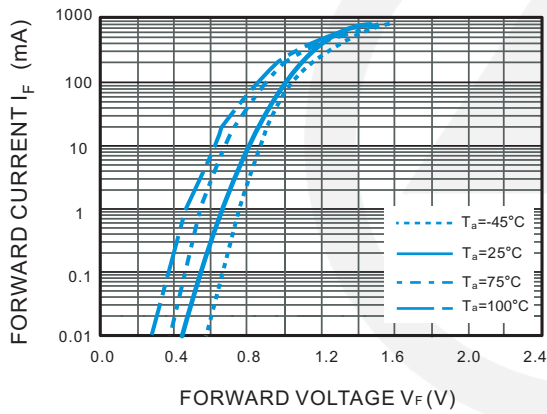
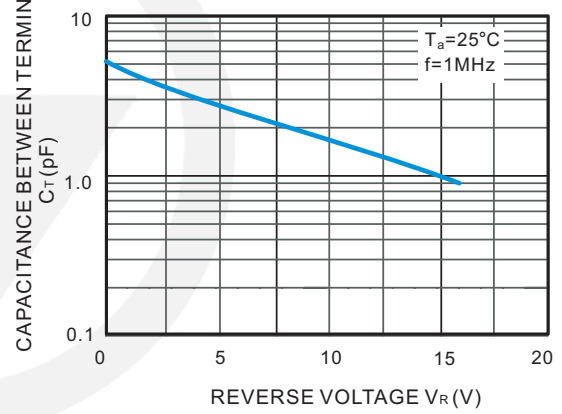
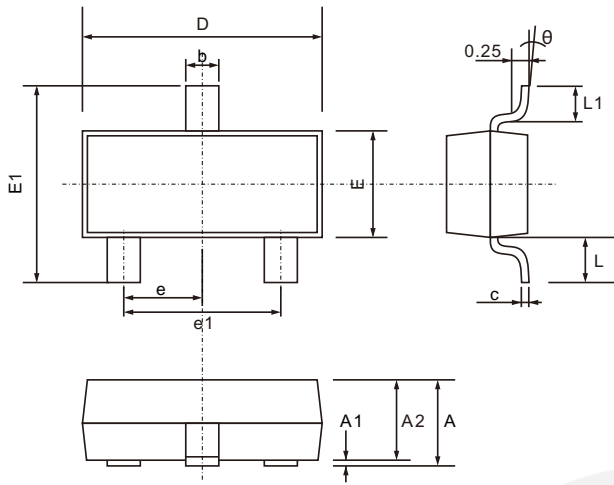

Fig.4 Capacitance Characteristics



**SOT-23 Package Outline**

Unit: mm



SYMBOL	DIMENSIONS	
	MIN.	MAX.
A	0.900	1.200
A1	0.000	0.100
A2	0.900	1.050
b	0.300	0.500
c	0.080	0.200
D	2.700	3.100
E	1.200	1.400
E1	2.200	2.600
e	0.950 TYP.	
e1	1.750	2.050
L	0.550 TYP.	
L1	0.300	0.500
θ	0°	8°

**SOT-23 Suggested Pad Layout**

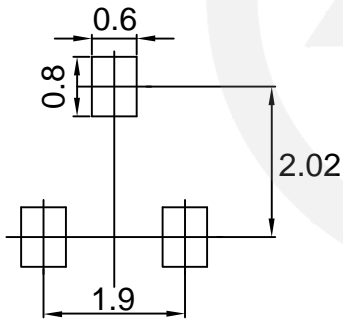

Note:  
 1. Controlling dimension: in millimeters.  
 2. General tolerance:  $\pm 0.05$  mm  
 3. The pad layout is for reference purpose only.

**Carrier Tape Dimensions**

Unit : mm

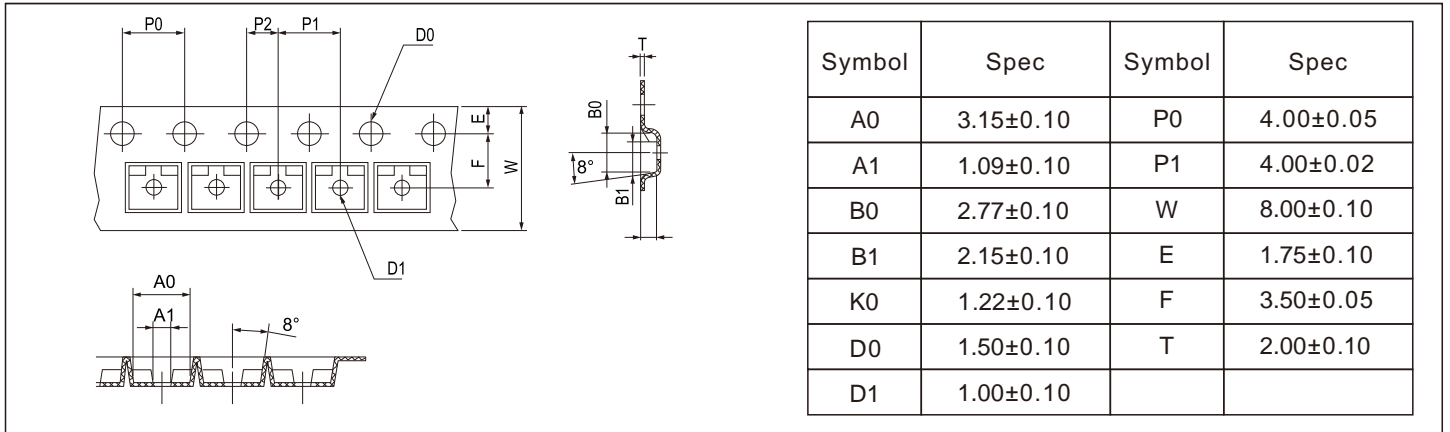

**Reel Dimensions**

Unit : mm

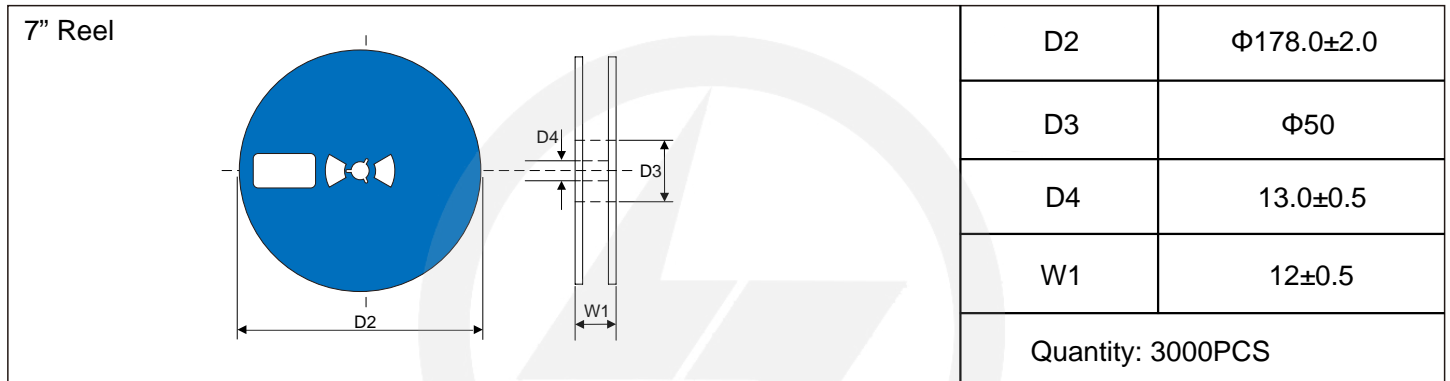

**Reel Dimensions**

Unit : mm

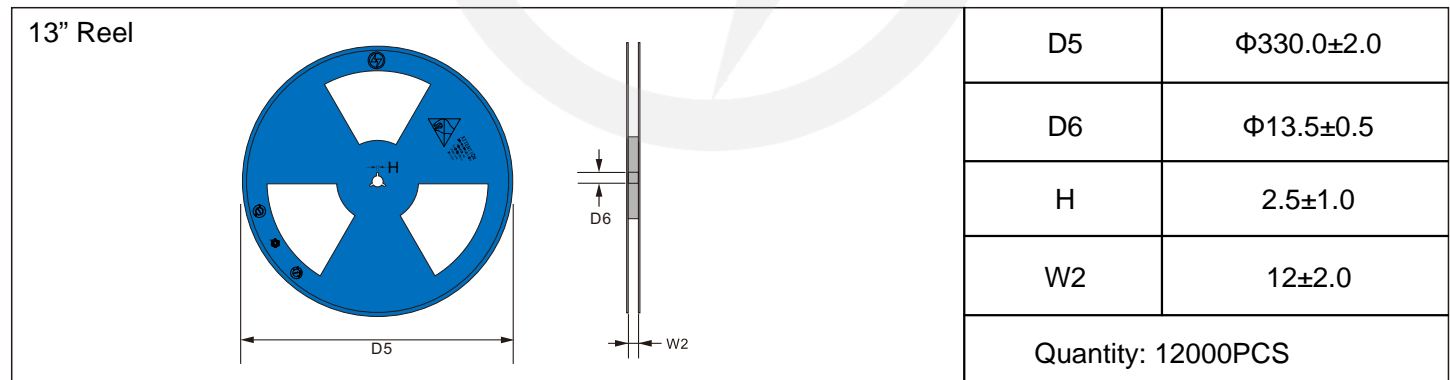

**Packaging**

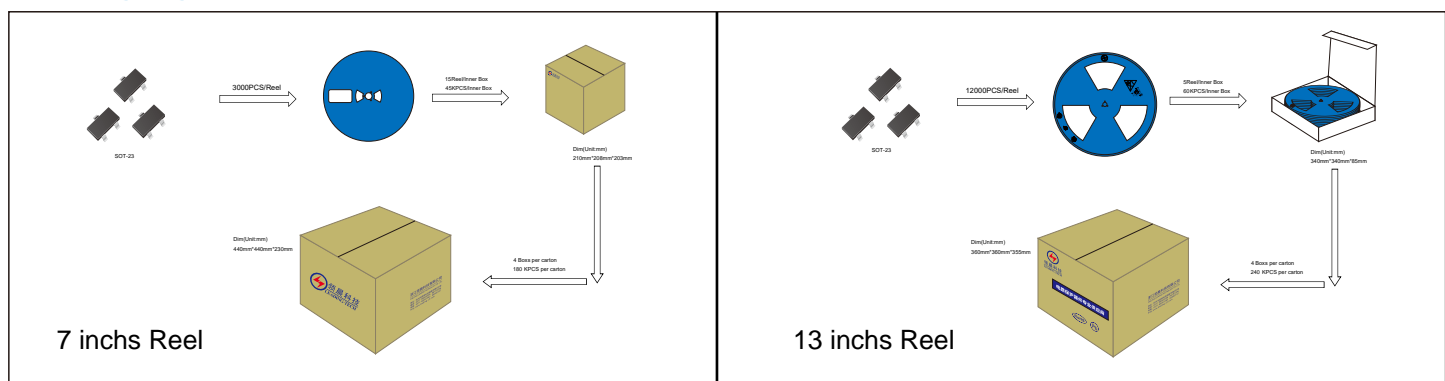



Recommended Soldering Conditions



Recommended Conditions

Profile Feature	Pb-Free Assembly
Average ramp-up rate (T <sub>L</sub> to T <sub>P</sub> )	3°C/second max.
Preheat	
-Temperature Min (T <sub>S min</sub> )	150°C
-Temperature Max (T <sub>S max</sub> )	200°C
-Time (min to max) (t <sub>s</sub> )	60-180 seconds
T <sub>S max</sub> to T <sub>L</sub>	
-Ramp-up Rate	3°C/second max.
Time maintained above:	
-Temperature (T <sub>L</sub> )	217°C
-Time (t <sub>L</sub> )	60-150 seconds
Peak Temperature (T <sub>P</sub> )	260°C
Time within 5°C of actual Peak Temperature (t <sub>p</sub> )	20-40 seconds
Ramp-down Rate	6°C/second max.
Time 25°C to Peak Temperature	8 minutes max.

## Important Notice and Disclaimer

Leading-Tech reserves the right to make changes to this document and its products and specifications at any time without notice.

Customers should obtain and confirm the latest product information and specifications before final design, purchase or use.

Leading-Tech makes no warranty, representation or guarantee regarding the suitability of its products for any particular purpose, not does Leading-Tech assume any liability for application assistance or customer product design.

Leading-Tech does not warrant or accept any liability with products which are purchase or used for any unintended or unauthorized application.

No license is granted by implication or otherwise under any intellectual property rights of Leading-Tech.

Leading-Tech products are not authorized for use as critical components in life support devices or systems without express written approval of Leading-Tech.

## Version Update Information

Series NO.	Enactment/Revision Date	Effective Date	Version	Revision Content	Revision Reason	Revision Person	Note
01	2024.03.18	2024.03.18	3.0	New file	/	Ding	
02	2025.06.17	2025.06.17	3.1	Update packaging information	/	Ding	
03	2026.03.09	2026.03.09	3.2	1.Package outline E1(max)=2.6mm 2.Add MSL1 and ESD:2000V(HBM) 3.Add VF and IR Curves	/	Ding	