

Glass Passivated High Voltage Rectifier

Features

- High surge forward current capability
- High voltage capability
- High voltage capability
- Low forward voltage drop
- Low leakage current
- High purity, high temperature epoxy encapsulation for enhanced mechanical strength and moisture resistance
- Lead free in comply with EU RoHS 2011/65/EU directives

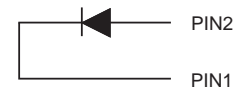
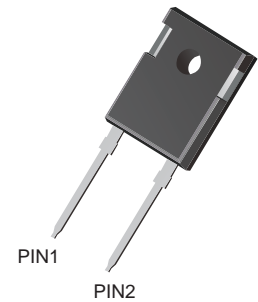

Mechanical data

- Case: TO-247-2L
- Case Material: "Green" molding compound, UL flammability classification 94V-0, "Halogen-free"
- Approx. Weight: 6.0g

Ordering Information

| Part Number | Marking | Shipping | Packing Type |
|-------------|---------|------------|--------------|
| LTG60160W | G60160W | 30PCS/Tube | Tube |

Maximum Ratings And Electrical Characteristics

Ratings At 25°C Ambient Temperature Unless Otherwise Specified

| Parameter | Symble | LTG60160W | Units |
|--|-----------------|-------------|---------------|
| Maximum Recurrent Peak Reverse Voltage | V_{RRM} | 1600 | V |
| Maximum RMS voltage | V_{RMS} | 1120 | V |
| Maximum DC Blocking Voltage | V_{DC} | 1600 | V |
| Maximum Average Forward Rectified Current @ $T_c=100^{\circ}C$ Per device | $I_{F(AV)}$ | 60 | A |
| Peak Forward Surge Current, 8.3ms Single Half Sine-wave Superimposed on Rated Load (JEDEC method) | I_{FSM} | 500 | A |
| Max Instantaneous Forward Voltage at 60 A | V_F | 1.12 | V |
| Maximum DC Reverse Current at $T_j = 25^{\circ}C$ Rated DC Reverse Voltage $T_j = 125^{\circ}C$ | I_R | 10 500 | μA |
| Typical Thermal Resistance | $R_{\theta JC}$ | 1.1 | $^{\circ}C/W$ |
| Operating Junction Temperature Range | T_j | -55 to +150 | $^{\circ}C$ |
| Storage Temperature Range | T_{stg} | -55 to +150 | $^{\circ}C$ |



Characteristics Curves

Fig.1 Forward Current Derating Curve

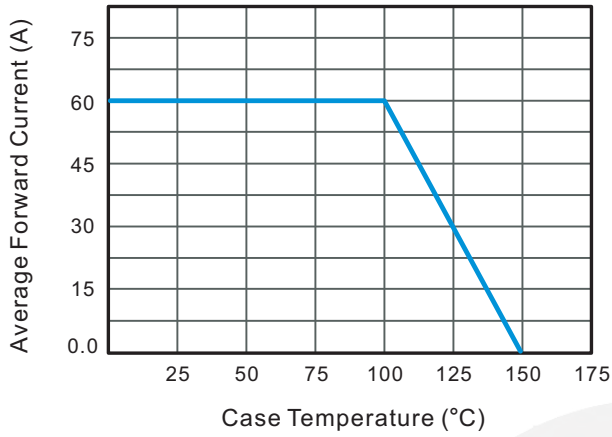

Fig.2 Typical Instantaneous Reverse Characteristics

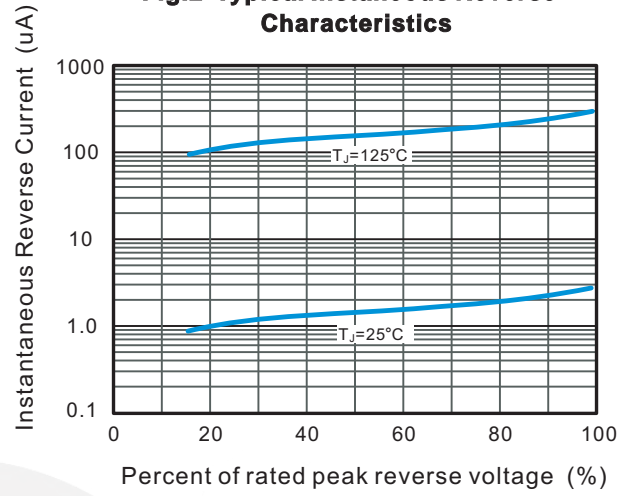

Fig.3 Typical Forward Characteristic

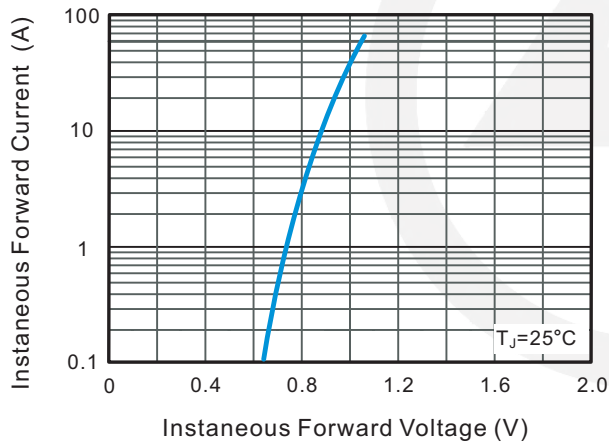
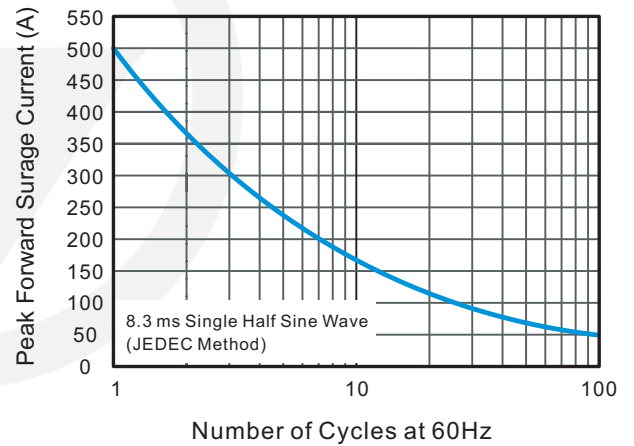
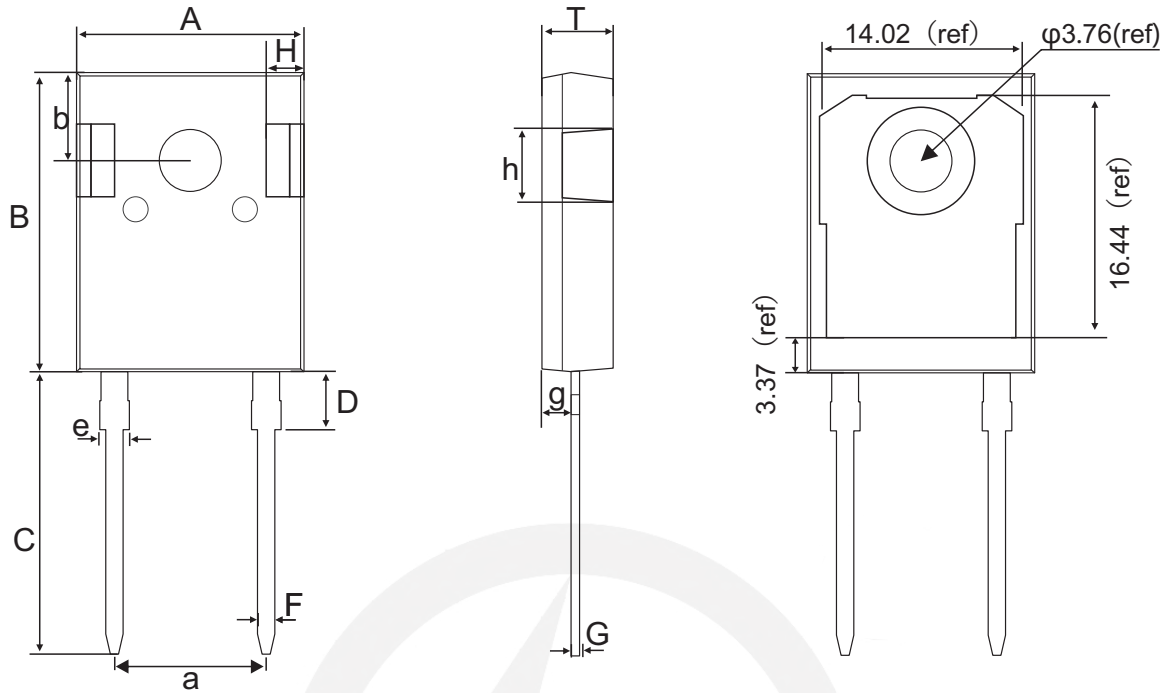

Fig.4 Maximum Non-Repetitive Peak Forward Surge Current





TO-247-2L Package Outline



| Unit | | A | B | b | C | D | e | F | g | G | T | a | H | h |
|------|-----|-------|-------|------|------|------|------|-----|------|-----|-----|-------|------|------|
| mm | max | 16.01 | 21.18 | 6.26 | 20.2 | 4.25 | 2.2 | 1.3 | 2.49 | 0.7 | 5.2 | 10.98 | 2.71 | 5.37 |
| | typ | 15.81 | 20.98 | 6.16 | 20.0 | 4.15 | 2.05 | 1.2 | 2.39 | 0.6 | 5.0 | 10.88 | 2.51 | 5.17 |
| | min | 15.61 | 20.78 | 6.06 | 19.8 | 4.05 | 1.9 | 1.1 | 2.29 | 0.5 | 4.8 | 10.78 | 2.31 | 4.97 |

Important Notice and Disclaimer

Leading-Tech reserves the right to make changes to this document and its products and specifications at any time without notice.

Customers should obtain and confirm the latest product information and specifications before final design, purchase or use.

Leading-Tech makes no warranty, representation or guarantee regarding the suitability of its products for any particular purpose, nor does Leading-Tech assume any liability for application assistance or customer product design.

Leading-Tech does not warrant or accept any liability with products which are purchased or used for any unintended or unauthorized application.

No license is granted by implication or otherwise under any intellectual property rights of Leading-Tech.

Leading-Tech products are not authorized for use as critical components in life support devices or systems without express written approval of Leading-Tech.

Version Update Information

| Series NO. | Enactment/Revision Date | Effective Date | Version | Revision Content | Revision Reason | Revision Person | Note |
|------------|-------------------------|----------------|---------|------------------|-----------------|-----------------|------|
| 01 | 2025.06.10 | 2025.06.10 | 3.0 | New file | / | Ding | |