

Uni-direction ESD Protection Diode

Features

- Uni-directional ESD protection of one line
- Reverse stand-off voltage: 5V
- Low reverse clamping voltage
- Low leakage current
- Excellent package: 2.90mm×1.30mm×1.00mm
- Fast response time
- JESD22-A114-B ESD Rating of class 3B per human body model
- IEC 61000-4-2 Level 4 ESD protection
- Lead free in comply with EU RoHS 2011/65/EU directives

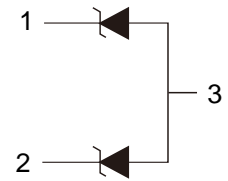
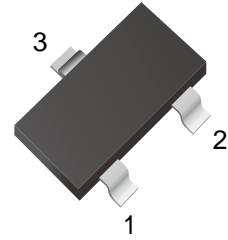

Mechanical Data

- Case: SOT-23
- Flammability Rating: UL 94V-0
- Approx. Weight: 8.1mg

Applications

- Computers and peripherals
- Audio and video equipment
- Cellular handsets and accessories
- Portable electronics
- Other electronics equipments communication systems

Ordering Information

Part Number	Marking	Shipping	Reel
LTESD5V0AP-TR3	5M	3000PCS Tape&Reel	7 inches
LTESD5V0AP-TR12	5M	12000PCS Tape&Reel	13 inches

Absolute Maximum Ratings (T_{amb}=25°C unless otherwise specified)

Parameter	Symbol	Limit	Unit
IEC 61000-4-2 ESD Voltage	V _{ESD} ⁽¹⁾	±25	kV
		Air Model	
		Contact Model	
		Per Human Body Model	
JESD22-A114-B ESD Voltage		±16	
ESD Voltage	Machine Model	±0.4	
Peak Pulse Power	P _{PP} ⁽²⁾	170	W
Peak Pulse Current	I _{PP} ⁽²⁾	13	A
Lead Solder Temperature – Maximum (10 Second Duration)	T _L	260	°C
Junction Temperature	T _j	150	°C
Storage Temperature Range	T _{stg}	-55 to +150	°C

(1). Device stressed with ten non-repetitive ESD pulses.

(2). Non-repetitive current pulse 8/20μs exponential decay waveform according to IEC61000-4-5.

ESD standards compliance

IEC61000-4-2 Standard

Contact Discharge		Air Discharge	
Level	Test Voltage kV	Level	Test Voltage kV
1	2	1	2
2	4	2	4
3	6	3	8
4	8	4	15

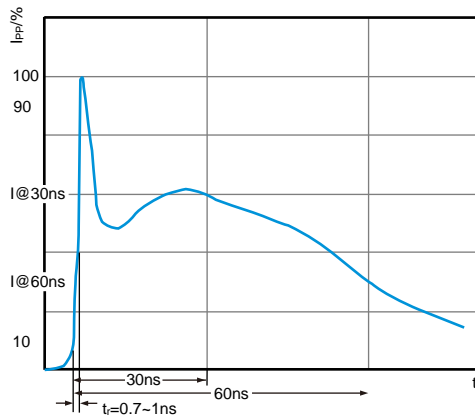

ESD pulse waveform according to IEC61000-4-2

JESD22-A114-B Standard

ESD Class	Human Body Discharge V
0	0 ~ 249
1A	250 ~ 499
1B	500 ~ 999
1C	1000 ~ 1999
2	2000 ~ 3999
3A	4000 ~ 7999
3B	8000 ~ 15999

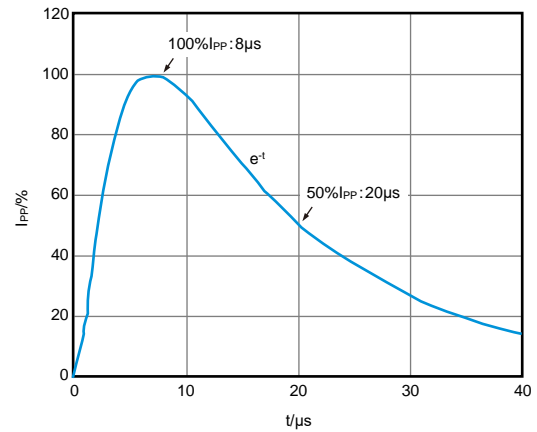

8/20µs pulse waveform according to IEC 61000-4-5

Electrical Parameter

Symbol	Parameter
V_C	Clamping Voltage @ I_{PP}
I_{PP}	Peak Pulse Current
V_{BR}	Breakdown Voltage @ I_T
I_T	Test Current
I_R	Reverse Leakage Current @ V_{RWM}
V_{RWM}	Reverse Standoff Voltage
V_F	Forward Voltage @ I_F
I_F	Forward Current

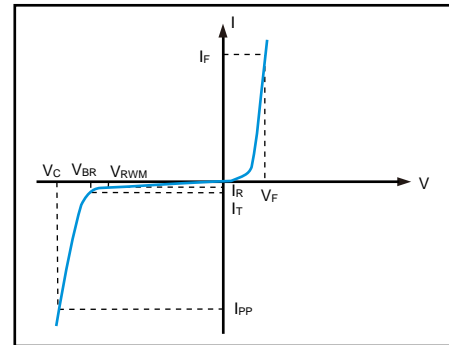

V-I characteristics for a uni-directional TVS

Electrical Characteristics (TA=25°C unless otherwise specified)

Parameter	Symbol	Test conditions	Min	Typ	Max	Unit
Reverse stand off voltage	$V_{RWM}^{(1)}$				5	V
Reverse leakage current	I_R	$V_{RWM}=12V$			10	µA
Breakdown voltage	$V_{(BR)}$	$I_T=1mA$	6.2		7.3	V
Clamping voltage	$V_C^{(2)}$	$I_{PP}=9A$			13	V
Forward voltage	V_F	$I_F=10mA$			0.9	V
Junction capacitance	C_J	$V_R=0V, f=1MHz$		95		pF

(1). Other voltages available upon request.

(2). Non-repetitive current pulse 8/20µs exponential decay waveform according to IEC61000-4-5.



Characteristic Curves

Fig.1 Forward Characteristics

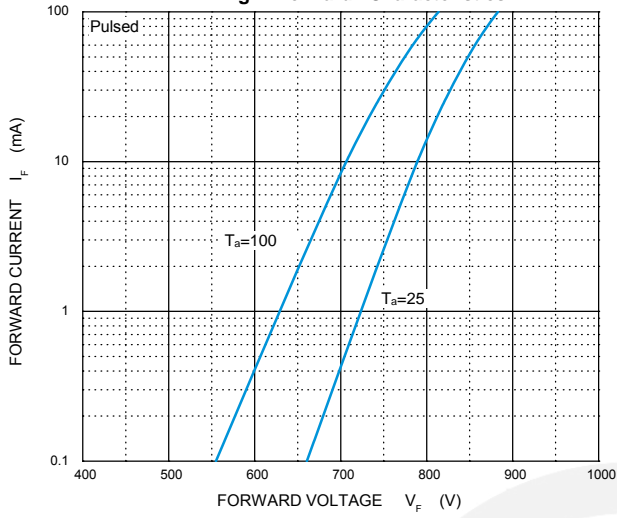

Fig.2 Reverse Characteristics

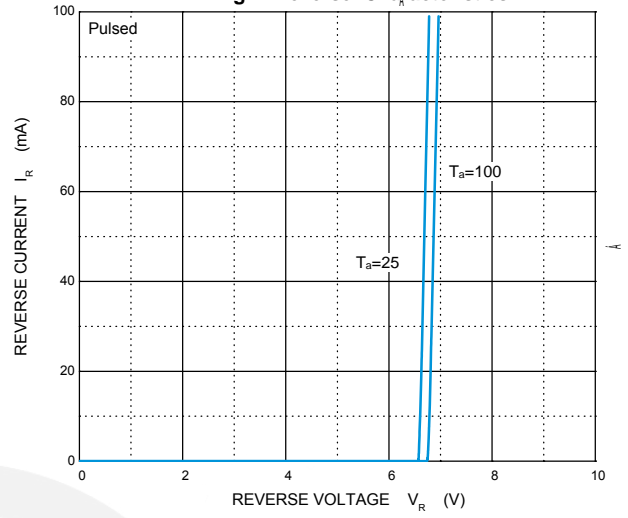

Fig.3 V_C vs I_{PP}

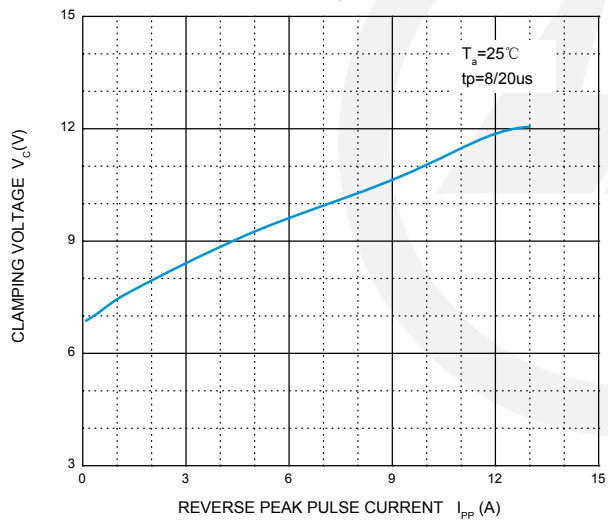
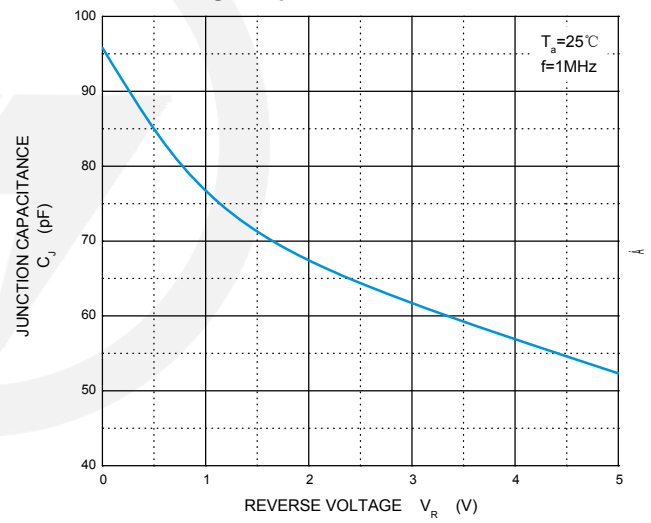
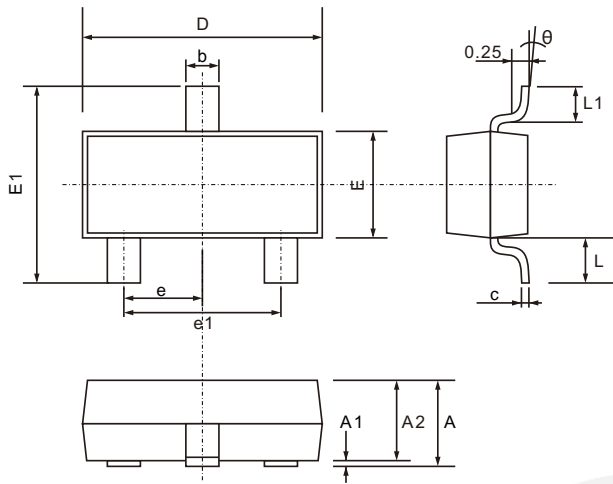

Fig.4 Capacitance Characteristics



SOT-23 Package Outline

Unit: mm



SYMBOL	DIMENSIONS	
	MIN.	MAX.
A	0.900	1.200
A1	0.000	0.100
A2	0.900	1.050
b	0.300	0.500
c	0.080	0.200
D	2.700	3.100
E	1.200	1.400
E1	2.200	2.600
e	0.950 TYP.	
e1	1.750	2.050
L	0.550 TYP.	
L1	0.300	0.500
θ	0°	8°

SOT-23 Suggested Pad Layout

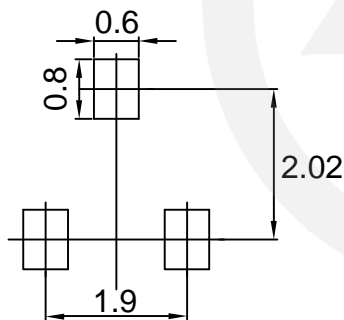

Note:
 1. Controlling dimension: in millimeters.
 2. General tolerance: $\pm 0.05\text{mm}$
 3. The pad layout is for reference purpose only.

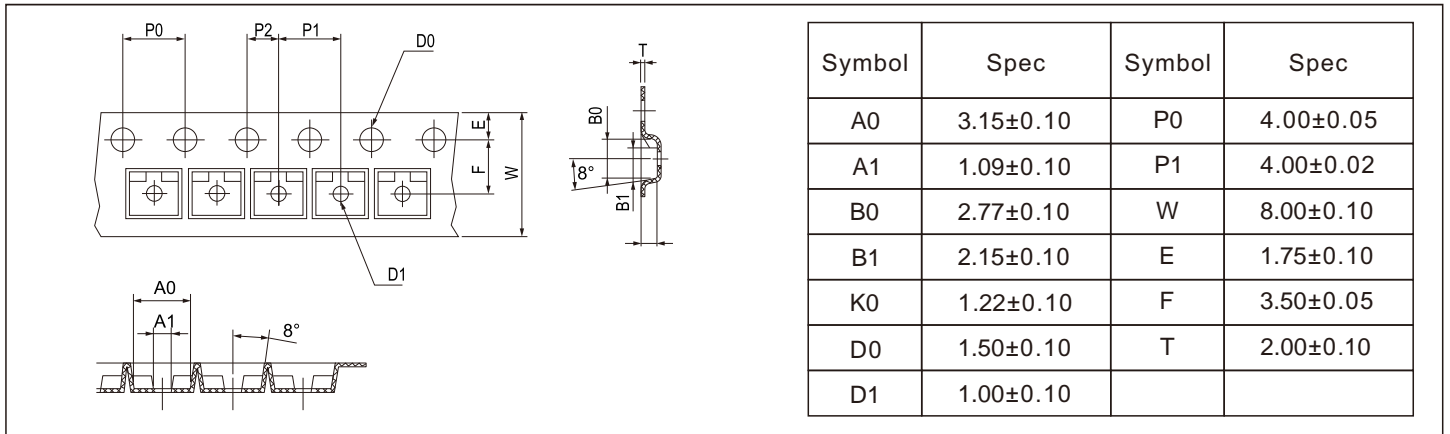
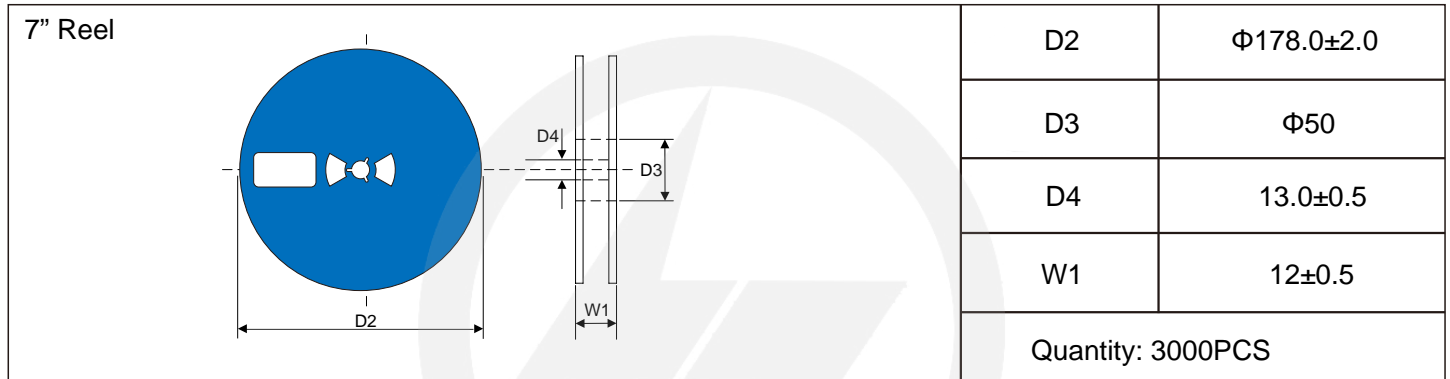
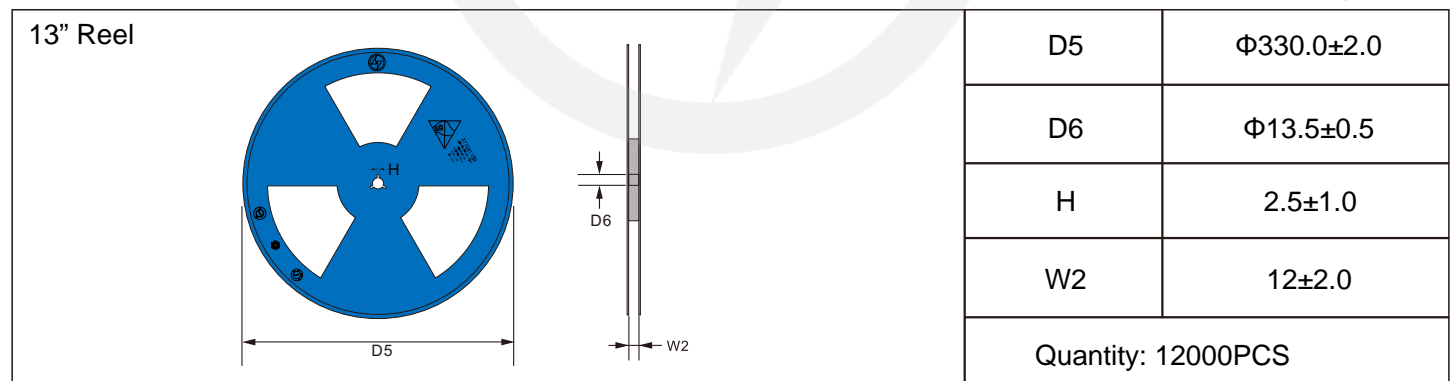
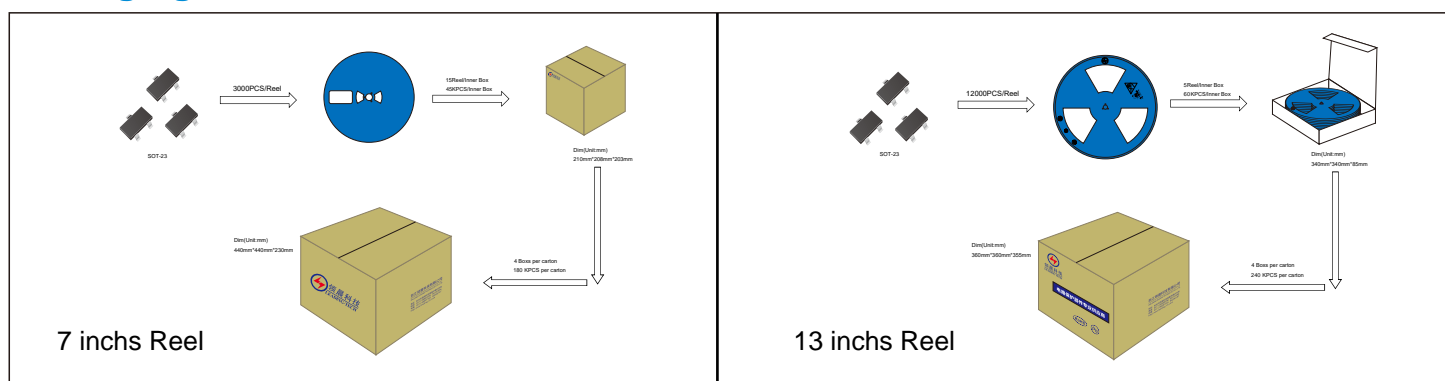
Carrier Tape Diemensions
Unit : mm

Reel Dimensions
Unit : mm

Reel Dimensions
Unit : mm

Packaging



Recommended Soldering Conditions



Recommended Conditions

Profile Feature	Pb-Free Assembly
Average ramp-up rate (T _L to T _P)	3°C/second max.
Preheat	
-Temperature Min (T _{S min})	150°C
-Temperature Max (T _{S max})	200°C
-Time (min to max) (t _s)	60-180 seconds
T _{S max} to T _L	
-Ramp-up Rate	3°C/second max.
Time maintained above:	
-Temperature (T _L)	217°C
-Time (t _L)	60-150 seconds
Peak Temperature (T _P)	260°C
Time within 5°C of actual Peak Temperature (t _p)	20-40 seconds
Ramp-down Rate	6°C/second max.
Time 25°C to Peak Temperature	8 minutes max.

Important Notice and Disclaimer

Leading-Tech reserves the right to make changes to this document and its products and specifications at any time without notice.

Customers should obtain and confirm the latest product information and specifications before final design, purchase or use.

Leading-Tech makes no warranty, representation or guarantee regarding the suitability of its products for any particular purpose, not does Leading-Tech assume any liability for application assistance or customer product design.

Leading-Tech does not warrant or accept any liability with products which are purchase or used for any unintended or unauthorized application.

No license is granted by implication or otherwise under any intellectual property rights of Leading-Tech.

Leading-Tech products are not authorized for use as critical components in life support devices or systems without express written approval of Leading-Tech.

Version Update Information

Series NO.	Enactment/Revision Date	Effective Date	Version	Revision Content	Revision Reason	Revision Person	Note
01	2025.06.30	2025.06.30	3.0	New file	/	Ding	
02	2026.03.06	2026.03.06	3.1	Package outline E1(max)=2.6mm	/	Ding	