

1-Line Bi-directional TVS Diode

Features

- Protects one data or power line
- Ultra low leakage: nA level
- Operating voltage: 5V
- Low clamping voltage
- IEC61000-4-2 ±30KV contact ±30KV air
- IEC61000-4-5 (lightning) 8A(8/20μs)
- Lead free in comply with EU RoHS 2011/65/EU directives

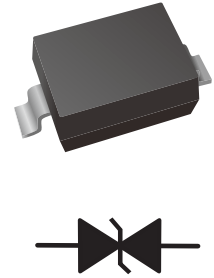

Mechanical Data

- Case: SOD-323
- Flammability Rating: UL 94V-0

Ordering Information

Part Number	Marking	Shipping	Reel
LTES05C01WD-TR3	B5	3000PCS Tape&Reel	7 inches
LTES05C01WD-TR12	B5	12000PCS Tape&Reel	13 inches

Absolute Maximum Ratings

Parameters	Symbol	Value	Unit
ESD per IEC61000-4-2(Air) ESD per IEC61000-4-2(Contact)	V _{ESD}	±30 ±30	kV
Peak Pulse Current (8/20μs) @Ta=25°C	I _{PP}	8	A
Total Power Dissipation on FR-5 Board @Ta=25°C	P _{PP}	100	W
Maximum Junction temperature	T _J	-55-+125	°C
Storage Temperature Range	T _{STG}	-55-+150	°C

Electrical Characteristics (Ta= 25°C unless otherwise noted, VF=0.9V Max.@ IF=10mA for all types)

Parameter	Symbol	Conditions	Min	Typ	Max	Units
Reverse Stand-Off voltage	V _{RWM}				5.0	V
Reverse Breakdown Voltage	V _{BR}	IT=1mA	5.6		8.0	V
Reverse Leakage Current	I _R	VRWM=5.0V			200	nA
Clamping Voltage	V _C	IPP=1A			8	V
		IPP=8A			13	V
Junction Capacitance	C _J	VR=0V,f=1MHz		18		pF

Characteristics Curve

Fig.1 Junction Capacitance vs Reverse Voltage

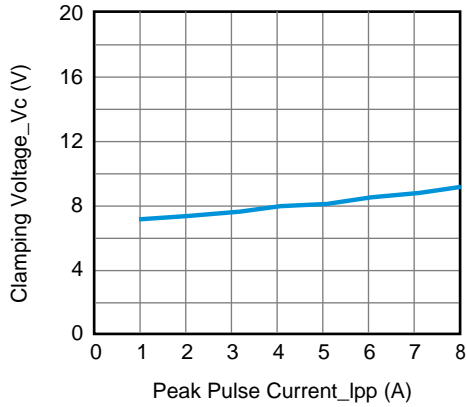

Fig.2 Peak Pulse Power vs Pulse Time

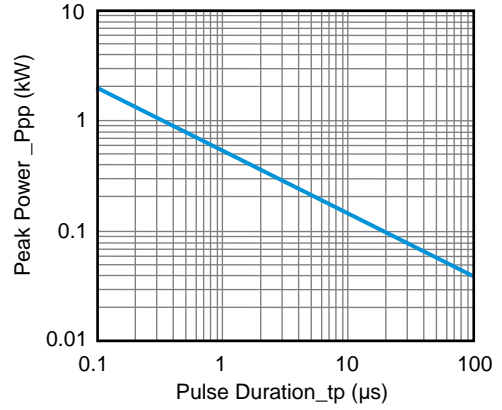

Fig.3 Clamping Voltage vs Peak Pulse Current (tp=8/20μs)

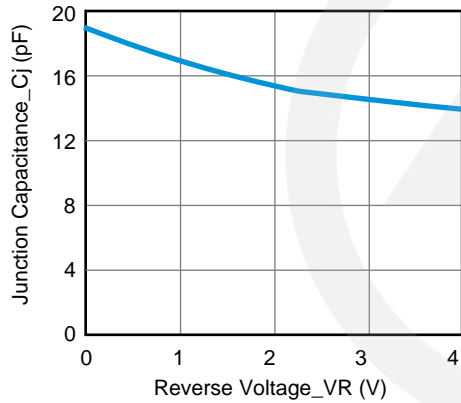

Fig.4 Power Derating Curve

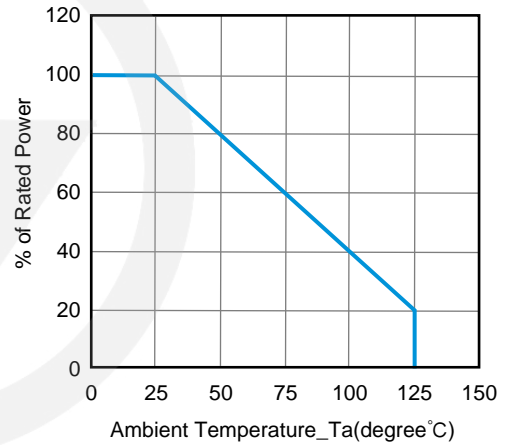
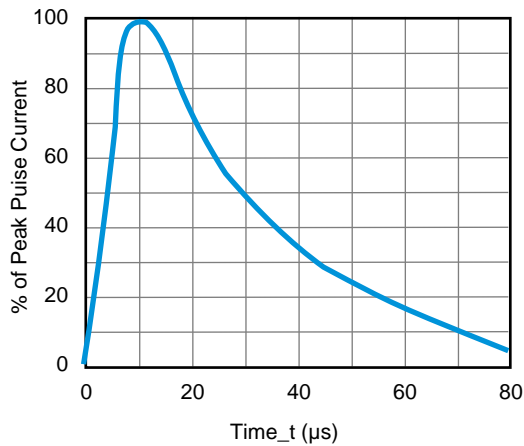
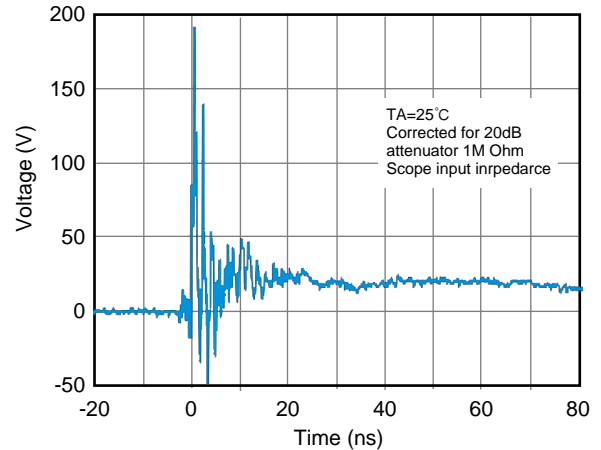

Fig.5 8 X 20μs Pulse Waveform



**Fig.6 ESD Clamping Voltage
8 kV Contact per IEC61000-4-2**





SOD-323 Package Outline

Unit: mm

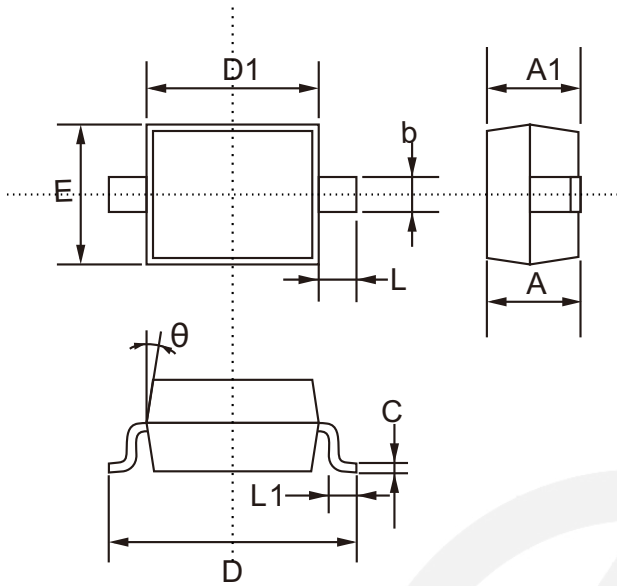

SYMBOL	DIMENSIONS	
	MIN.	MAX.
A	0.800	1.100
A1	0.800	0.900
b	0.250	0.400
C	0.080	0.177
D	2.300	2.800
D1	1.400	1.800
E	1.150	1.400
L1	0.100	0.400
L	0.475 TYP.	
θ	8°	

SOD-323 Suggested Pad Layout

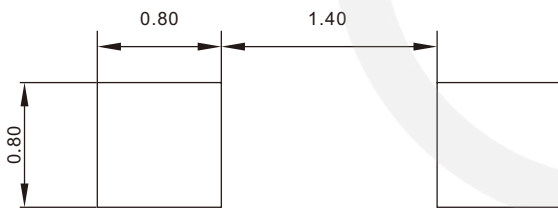

- Note:
1. Controlling dimension: in millimeters.
 2. General tolerance: $\pm 0.05\text{mm}$
 3. The pad layout is for reference purpose only.

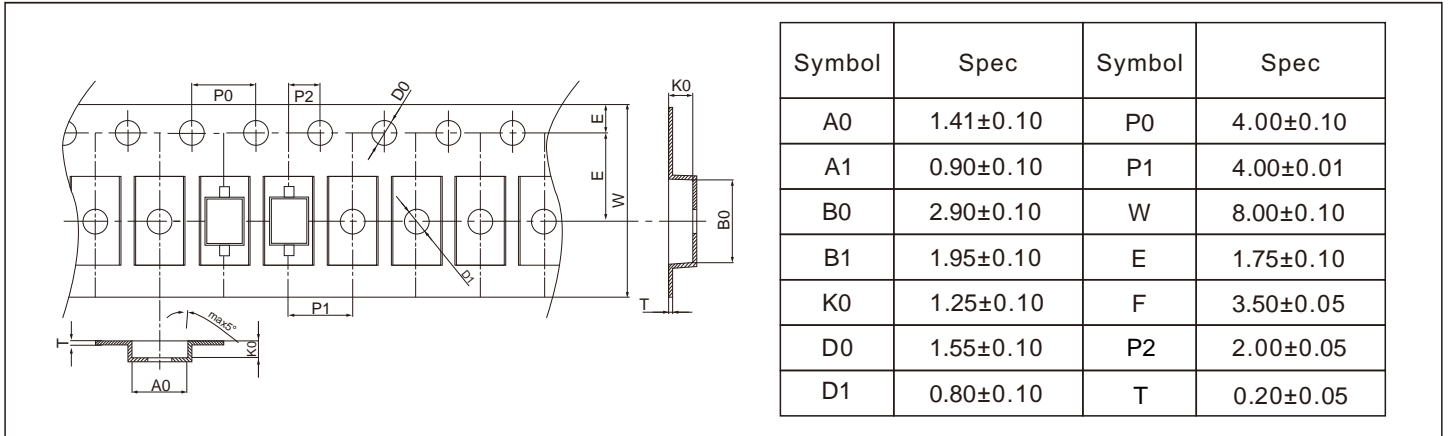
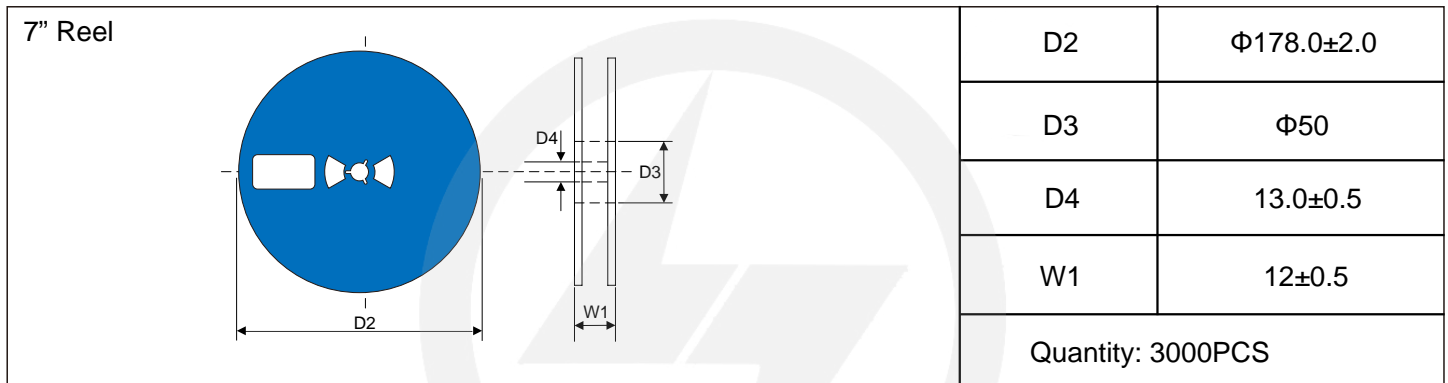
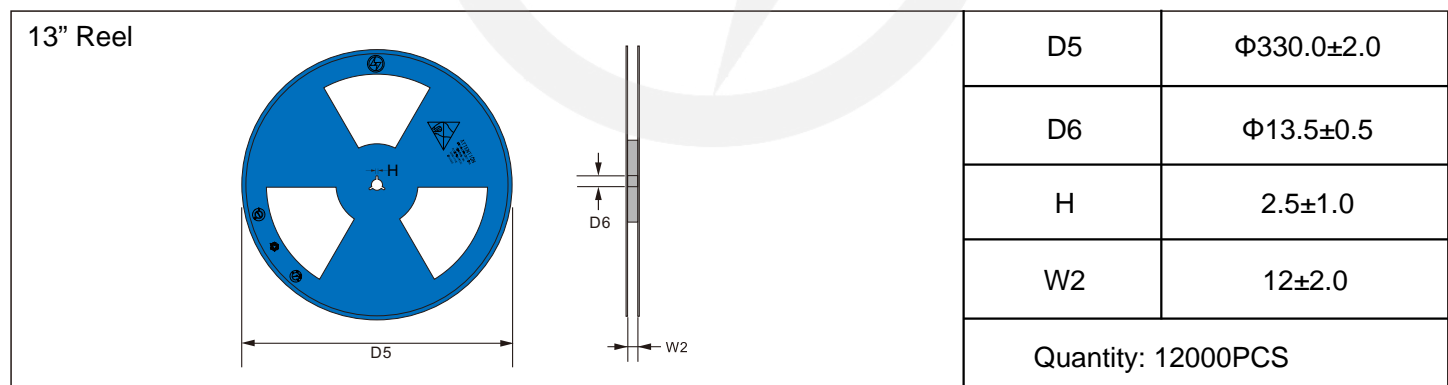
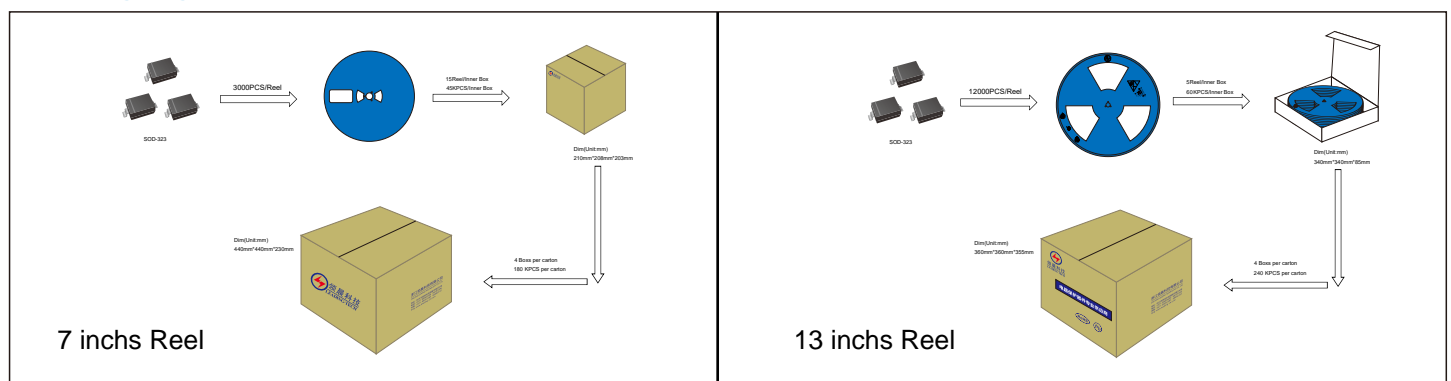
Carrier Tape Dimensions
Unit : mm

Reel Dimensions
Unit : mm

Reel Dimensions
Unit : mm

Packaging



Recommended Soldering Conditions



Recommended Conditions

Profile Feature	Pb-Free Assembly
Average ramp-up rate (T_L to T_P)	3°C/second max.
Preheat	
-Temperature Min ($T_{S\ min}$)	150°C
-Temperature Max ($T_{S\ max}$)	200°C
-Time (min to max) (t_s)	60-180 seconds
$T_{S\ max}$ to T_L	
-Ramp-up Rate	3°C/second max.
Time maintained above:	
-Temperature (T_L)	217°C
-Time (t_L)	60-150 seconds
Peak Temperature (T_P)	260°C
Time within 5°C of actual Peak Temperature (t_p)	20-40 seconds
Ramp-down Rate	6°C/second max.
Time 25°C to Peak Temperature	8 minutes max.

Important Notice and Disclaimer

Leading-Tech reserves the right to make changes to this document and its products and specifications at any time without notice.

Customers should obtain and confirm the latest product information and specifications before final design, purchase or use.

Leading-Tech makes no warranty, representation or guarantee regarding the suitability of its products for any particular purpose, not does Leading-Tech assume any liability for application assistance or customer product design.

Leading-tech does not warrant or accept any liability with products which are purchase or used for any unintended or unauthorized application.

No license is granted by implication or otherwise under any intellectual property rights of Leading-Tech.

Leading-Tech products are not authorized for use as critical components in life support devices or systems without express written approval of Leading-tech.

Version Update Information

Series NO.	Enactment/Revision Date	Effective Date	Version	Revision content	Revision Reason	Revision Person	Note
01	2025.01.16	2025.01.16	3.0	New File	/	Ding	