

ESD Protection Diddes

Features

- IEC 61000-4-2 (ESD)
 - ±30kV Contact Discharge
 - ±30kV Air Discharge
- 450W Peak pulse Power (8/20us)
- IEC 61000-4-4 EFT Protection
 - 40A (5/50ns)
- Halogen free and RoHS compliant
- Protects one power or I/O Transient protection for high-speed data lines
- Low clamping voltage
- Low leakage current
- Lead free in comply with EU RoHS 2011/65/EU directives

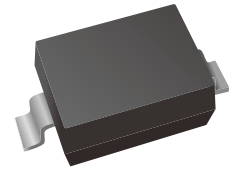

Mechanical Data

- Case: SOD-323
- Flammability Rating: UL 94V-0

Applications

- | | |
|--|---|
| <ul style="list-style-type: none"> ■ Interfaces <ul style="list-style-type: none"> - USB 2.0/1.1 - GPIO - Ethernet 10/100/1000 Mbps - Audio - Pushbuttons | <ul style="list-style-type: none"> ■ End Equipment <ul style="list-style-type: none"> - Industrial and Serve Robots - Laptops and Desktops - TV and Monitors - Wearables - Handheld-wireless Systems |
|--|---|

Ordering Information

Part Number	Marking	Shipping	Reel
LTES05C01CB-TR3	2B	3000PCS Tape&Reel	7 inchs
LTES05C01CB-TR12	2B	12000PCS Tape&Reel	13 inchs

Absolute Maximum Rating

Over operating free-air temperature range (unless otherwise noted)

Parameters	Symbol	Min	Max	Unit
Peak pulse power (tp=8/20us)@25°C	P _{pk}	-	450	W
Peak pulse current (tp=8/20us)@25°C	I _{PP}		30	A
ESD (IEC61000-4-2 air discharge) @25°C	V _{ESD}	-	±30	kV
ESD (IEC61000-4-2 contact discharge) @25°C	V _{ESD}	-	±30	kV
Junction temperature	T _J	-	150	°C
Operating temperature	T _{OP}	-40	125	°C
Storage temperature	T _{STG}	-55	150	°C
Lead temperature	T _L	-	260	°C

Electrical Characteristics

At TA = 25°C unless otherwise noted

Parameter	Symbol	Conditions	Min	Typ	Max	Units
Reverse Stand-off Voltage	V _{RWM}				5.0	V
Reverse Breakdown Voltage	V _{BR}	I _T =1mA	5.5			V
Reverse Leakage Current	I _R	V _{RWM} =5V			0.1	μA
Clamping Voltage	V _C	I _{PP} =1A; tp=8/20μs		9		V
Clamping Voltage	V _C	I _{PP} =30A; tp=8/20μs		15		V
Junction Capacitance	C _J	I/O to GND; VR=0V; f=1MHz		70		pF



Symbol	Parameters
V_{RWM}	Peak Reverse Working Voltage
I_R	Reverse Leakage Current @ V_{RWM}
V_{BR}	Breakdown Voltage @ I_T
I_T	Test Current
I_{PP}	Maximum Reverse Peak Pulse Current
V_C	Clamping Voltage @ I_{PP}

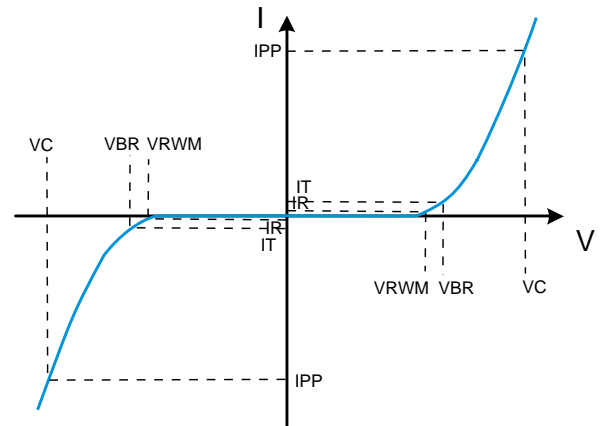

Characteristic Curves

Figure 1. Pulse rating curve

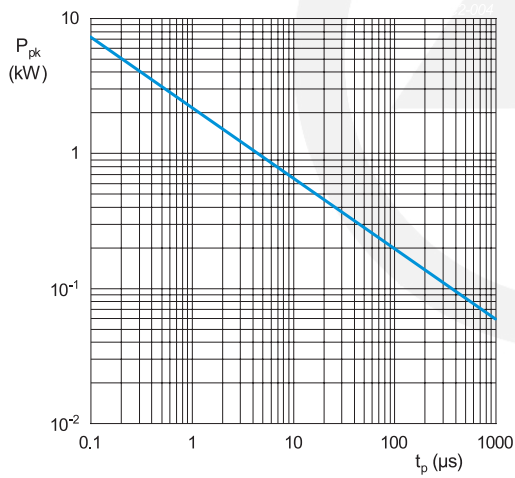

Figure 2 Peak pulse power derating curve

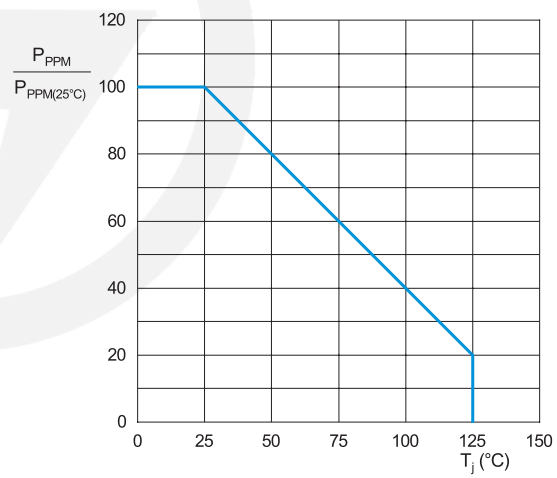
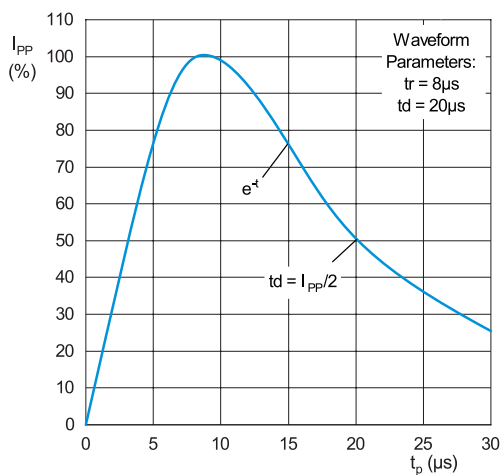
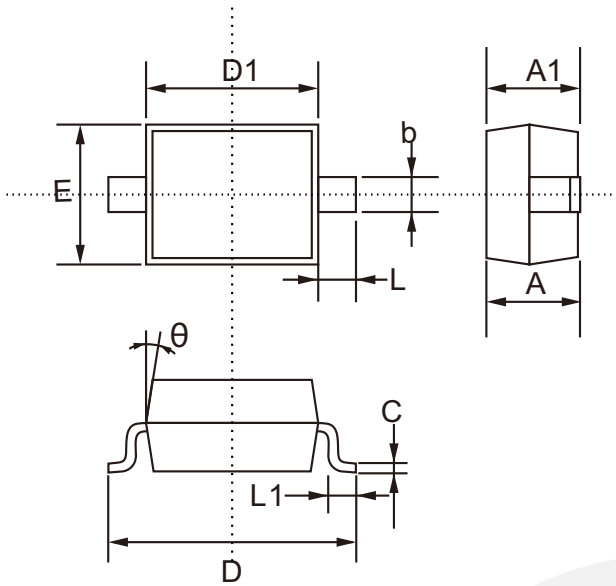

Figure 3 Pulse waveform



SOD-323 Package Outline

Unit: mm



SYMBOL	DIMENSIONS	
	MIN.	MAX.
A	0.800	1.100
A1	0.800	0.900
b	0.250	0.400
C	0.080	0.177
D	2.300	2.800
D1	1.400	1.800
E	1.150	1.400
L	0.475 TYP.	
θ	8°	

SOD-323 Suggested Pad Layout

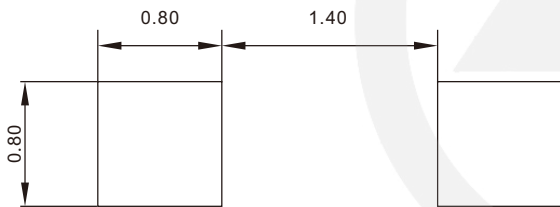

Note:
 1. Controlling dimension: in millimeters.
 2. General tolerance: $\pm 0.05\text{mm}$
 3. The pad layout is for reference purpose only.

Carrier Tape Dimensions

Unit : mm

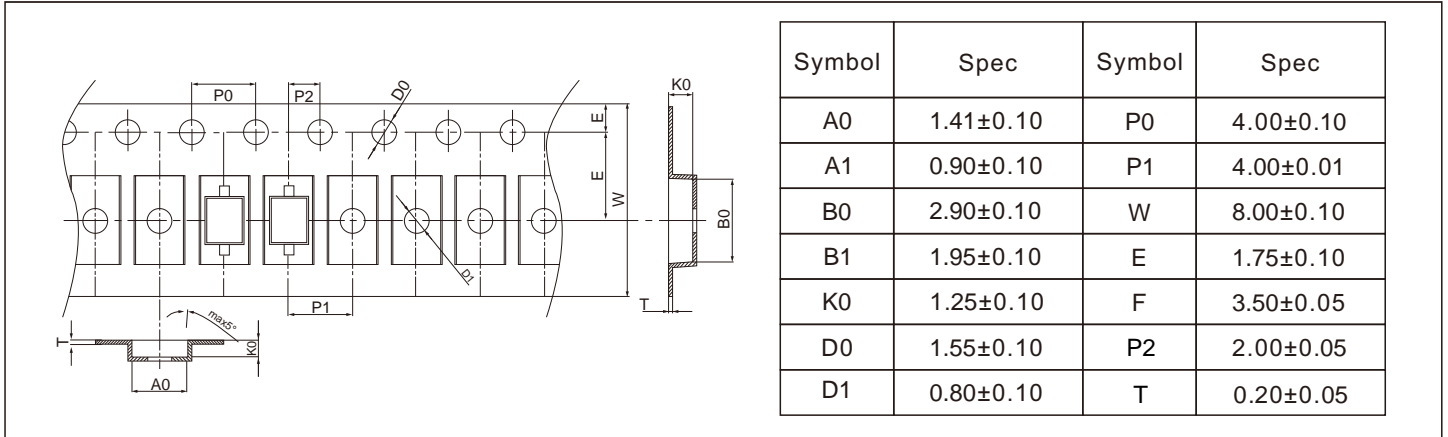

Reel Dimensions

Unit : mm

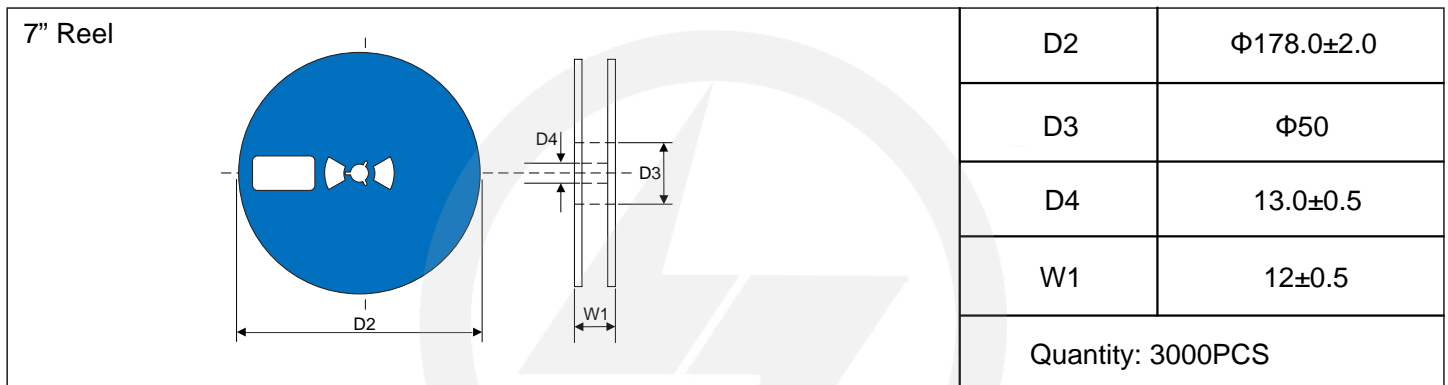

Reel Dimensions

Unit : mm

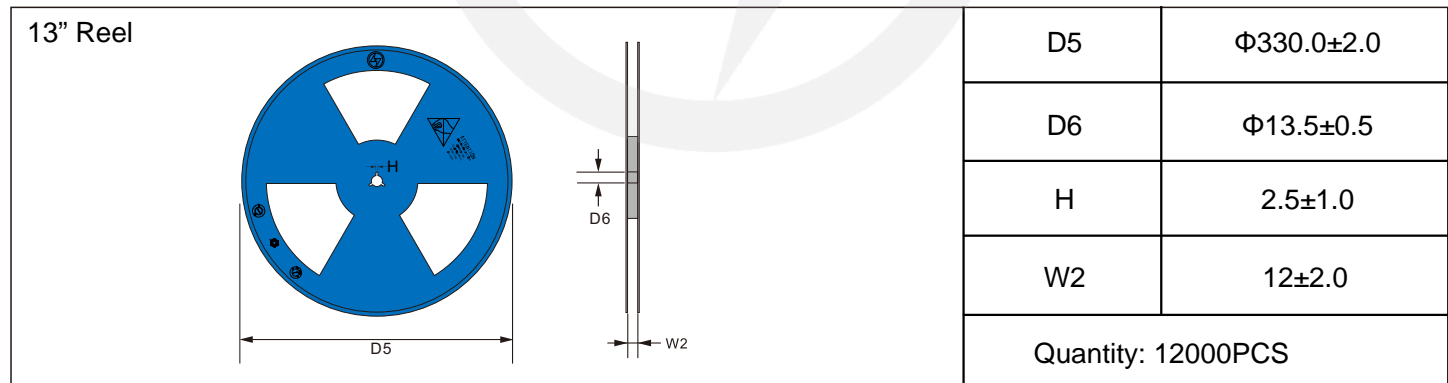

Packaging

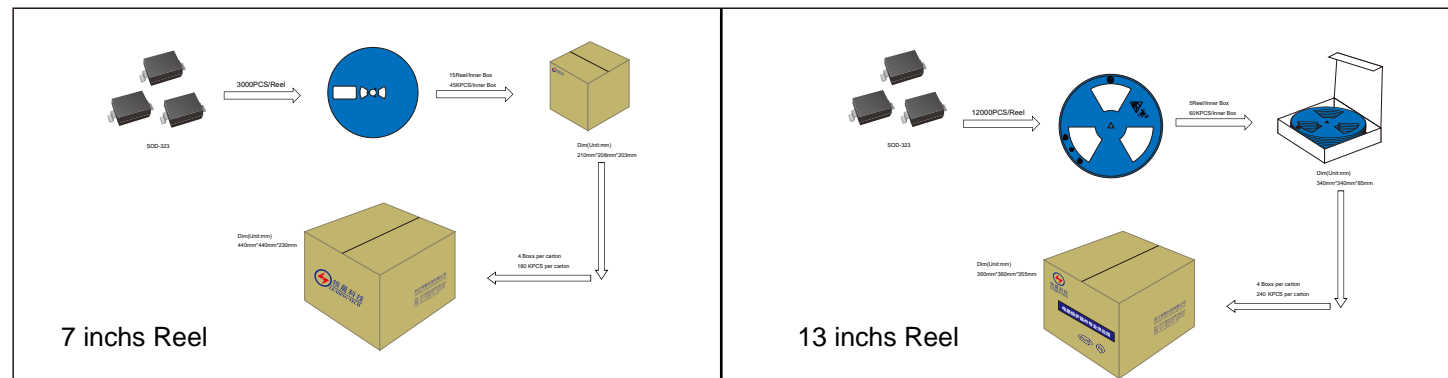



Recommended Soldering Conditions

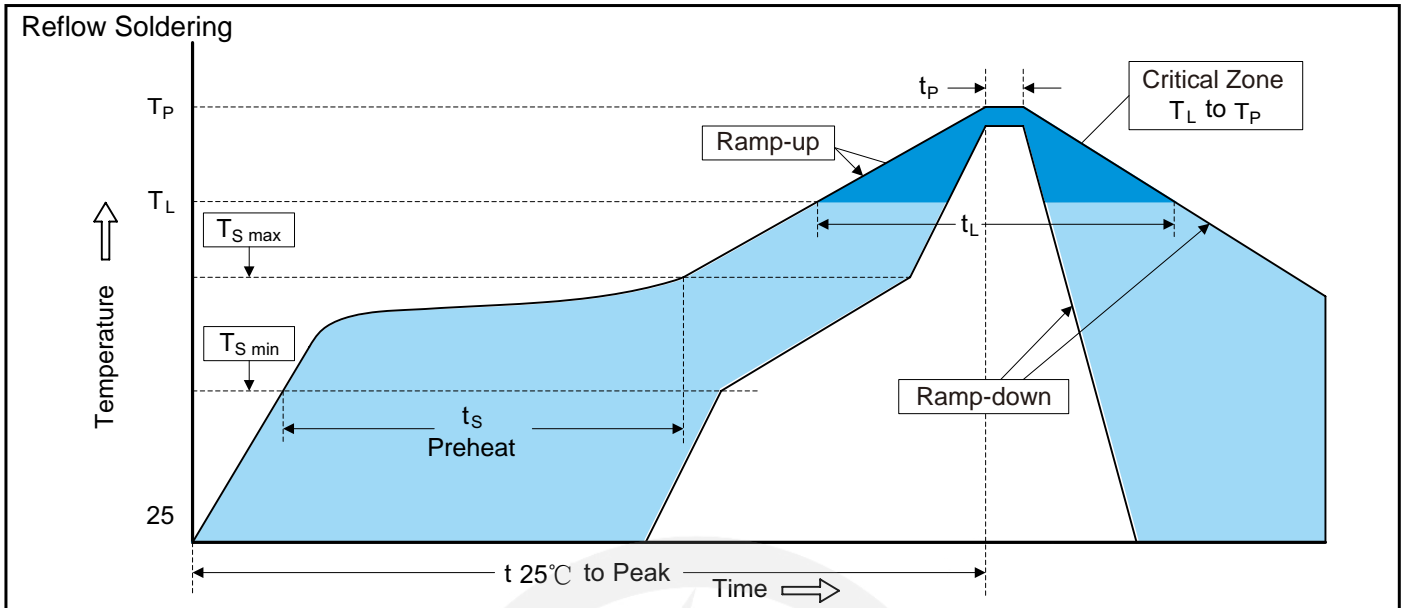

Recommended Conditions

Profile Feature	Pb-Free Assembly
Average ramp-up rate (T _L to T _P)	3°C/second max.
Preheat	
-Temperature Min (T _{S min})	150°C
-Temperature Max (T _{S max})	200°C
-Time (min to max) (t _s)	60-180 seconds
T _{S max} to T _L	
-Ramp-up Rate	3°C/second max.
Time maintained above:	
-Temperature (T _L)	217°C
-Time (t _L)	60-150 seconds
Peak Temperature (T _P)	260°C
Time within 5°C of actual Peak Temperature (t _p)	20-40 seconds
Ramp-down Rate	6°C/second max.
Time 25°C to Peak Temperature	8 minutes max.

Important Notice and Disclaimer

Leading-Tech reserves the right to make changes to this document and its products and specifications at any time without notice.

Customers should obtain and confirm the latest product information and specifications before final design, purchase or use.

Leading-Tech makes no warranty, representation or guarantee regarding the suitability of its products for any particular purpose, not does Leading-Tech assume any liability for application assistance or customer product design.

Leading-tech does not warrant or accept any liability with products which are purchase or used for any unintended or unauthorized application.

No license is granted by implication or otherwise under any intellectual property rights of Leading-Tech.

Leading-Tech products are not authorized for use as critical components in life support devices or systems without express written approval of Leading-tech.

Version Update Information

Series NO.	Enactment/Revision Date	Effective Date	Version	Revision content	Revision Reason	Revision Person	Note
01	2024.08.18	2024.08.18	3.0	New File	/	Ding	