

Bidirectional TVS Diodes for ESD Protection

Features

- IEC61000-4-2 (ESD) $\pm 30\text{kV}$ (air)
 $\pm 30\text{kV}$ (contact)
- IEC61000-4-4 (EFT) 40A (5/50ns)
- 168 Watts Peak Pulse Power per (tp=8/20 μs)
- Protects one I/O line (bidirectional)
- Low clamping voltage
- Working voltages : 5V
- Low leakage current

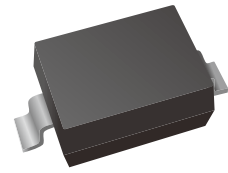

Mechanical Dates

- Case: SOD-323
- Flammability Rating: UL 94V-0

Applications

- Cell Phone Handsets and Accessories
- Microprocessor based equipment
- Personal Digital Assistants (PDA's)
- Notebooks, Desktops, and Servers
- Portable Instrumentation
- Networking and Telecom
- Serial and Parallel Ports
- Peripherals

Ordering Information

Part Number	Marking	Shipping	Reel
LTES05C01BA-TR3	E6	3000PCS Tape&Reel	7 inchs
LTES05C01BA-TR12	E6	12000PCS Tape&Reel	13 inchs

Absolute Maximum Ratings (T_A=25°C unless otherwise specified)

Symbol	Parameter	Value	Units
V _{ESD}	ESD per IEC 61000-4-2 (Air)	± 30	kV
	ESD per IEC 61000-4-2 (Contact)	± 30	
P _{PP}	Peak Pulse Power (8/20 μs)	168	W
T _{OPT}	Operating Temperature	-55/+150	°C
T _{STG}	Storage Temperature	-55/+150	°C
T _L	Lead Soldering Temperature	260 (10 sec.)	°C

Electrical Characteristics ($T_A=25^{\circ}\text{C}$ unless otherwise specified)

Part Number	Device Marking	V_{RWM} (V) (max.)	V_B (V) (min.)	I_T (mA)	$V_C@1A(V)$ (max.)	V_C (V) (max.) (@A)	I_R (nA) (max.)	C_T (pF) (max.)
LTES05C01BA	E6	5.0	5.5	1	10	14	12	100

Characteristics Curve
Fig. 1 8/20 μs pulse waveform according to IEC 61000-4-5

Fig. 2 ESD pulse waveform according to IEC 61000-4-2

Fig. 3 Peak pulse power as a function of exponential pulse duration; typical values

Fig. 4 Relative variation of peak pulse power as a function of junction temperature; typical values

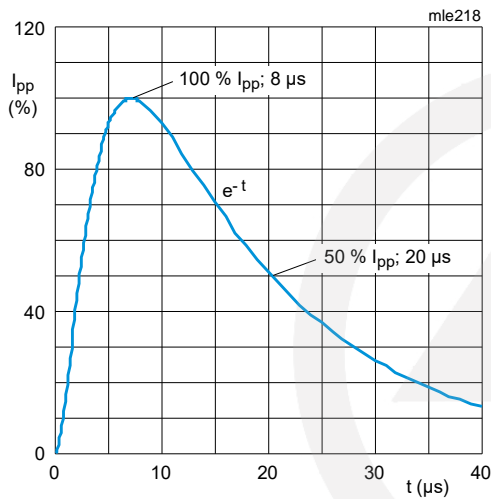
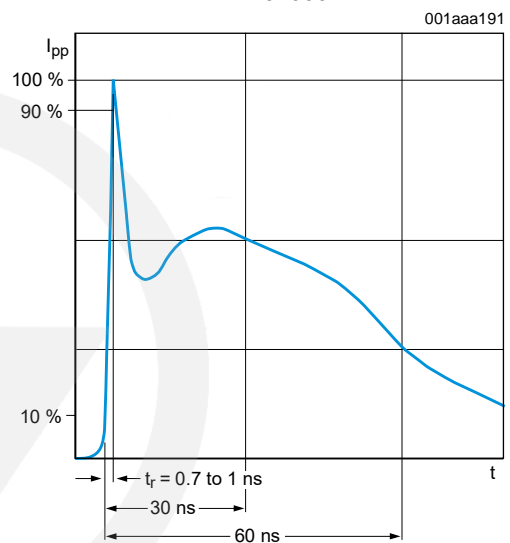
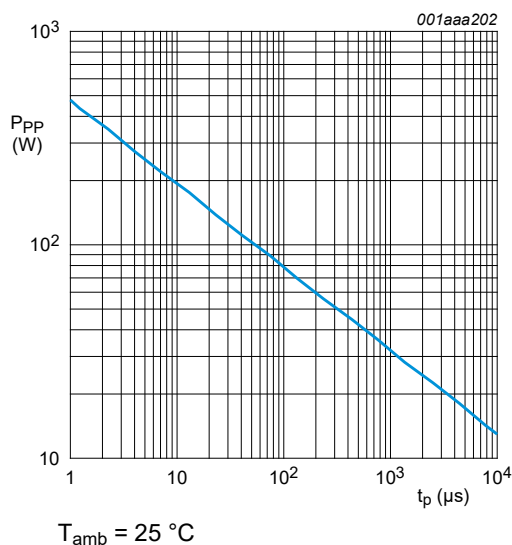
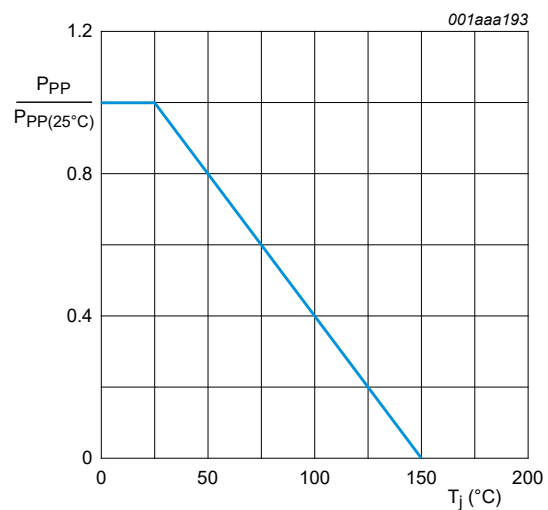

Fig. 5 Diode capacitance as a function of reverse voltage; typical values

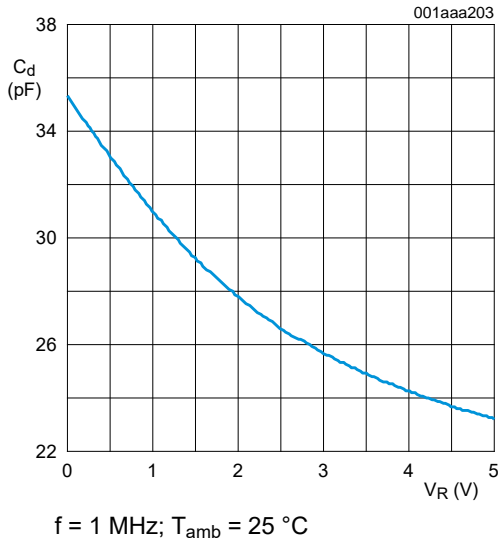
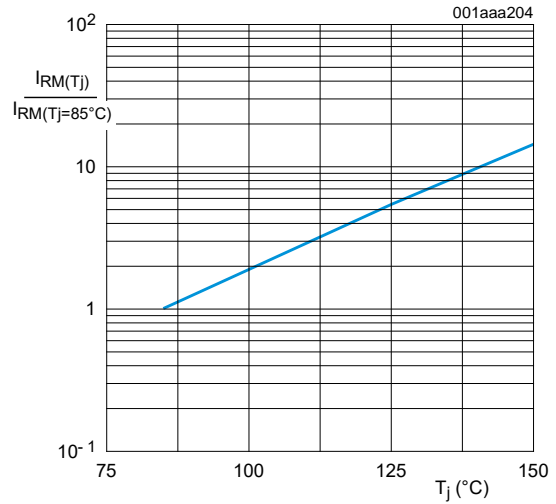
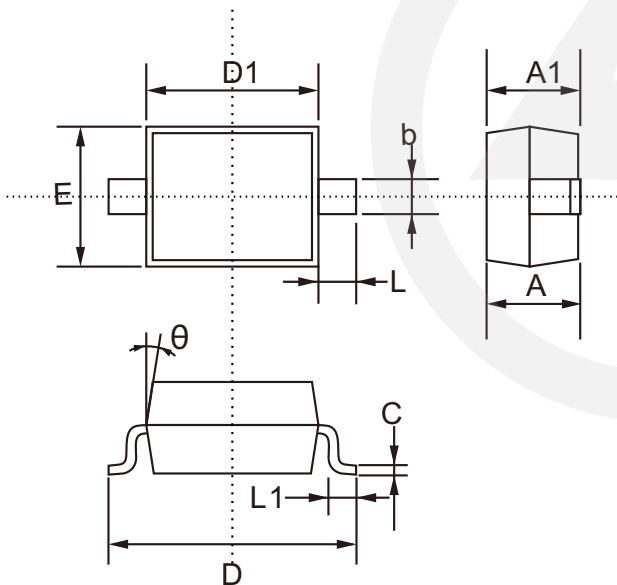

Fig. 6 Relative variation of reverse leakage current as a function of junction temperature; typical values



SOD-323 Package Outline

Unit: mm



SYMBOL	DIMENSIONS	
	MIN.	MAX.
A	0.800	1.100
A1	0.800	0.900
b	0.250	0.400
C	0.080	0.177
D	2.300	2.800
D1	1.400	1.800
E	1.150	1.400
L1	0.100	0.400
L	0.475 TYP.	
θ	8°	

SOD-323 Suggested Pad Layout

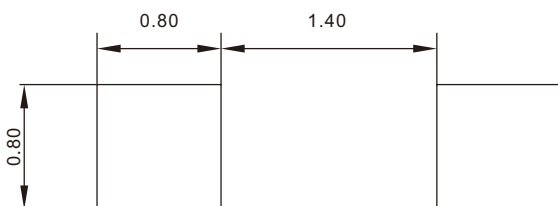

Note:
1. Controlling dimension: in millimeters.
2. General tolerance: $\pm 0.05\text{mm}$
3. The pad layout is for reference purpose only.

Carrier Tape Dimensions

Unit : mm

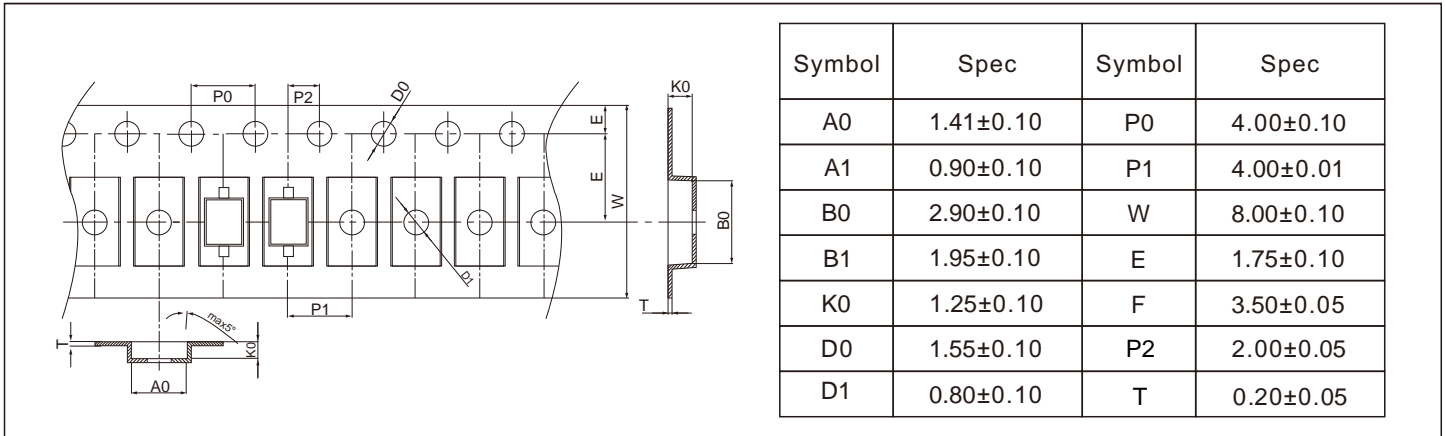

Reel Dimensions

Unit : mm

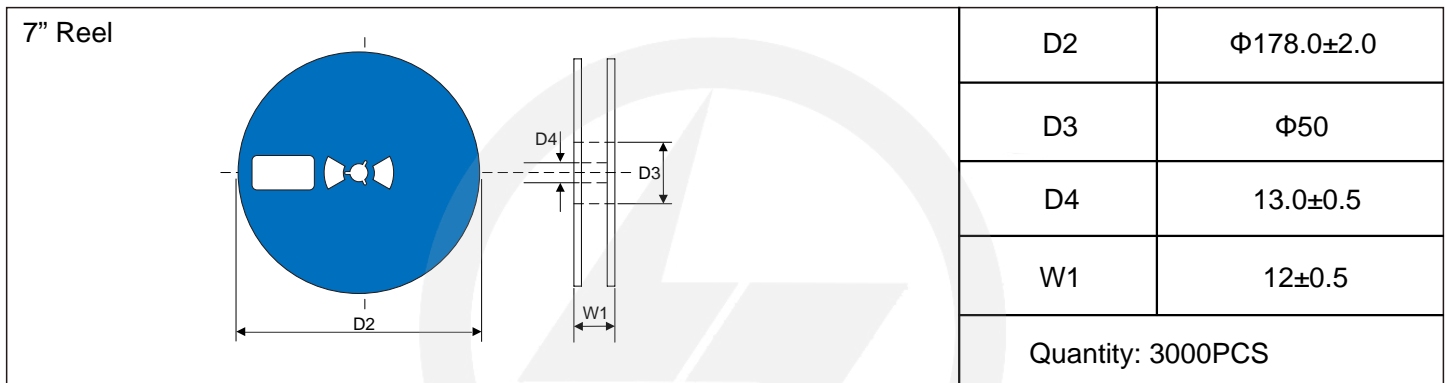

Reel Dimensions

Unit : mm

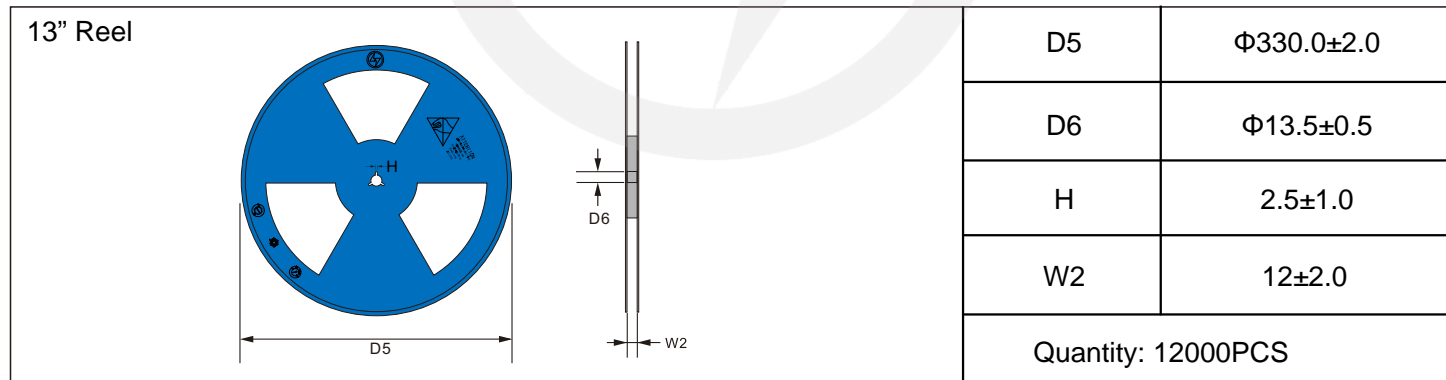

Packaging

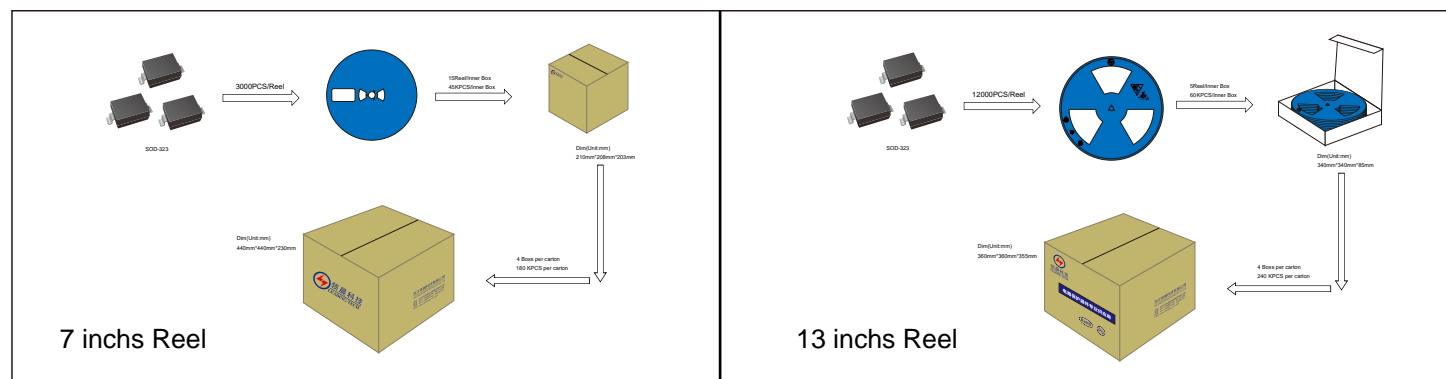



Recommended Soldering Conditions

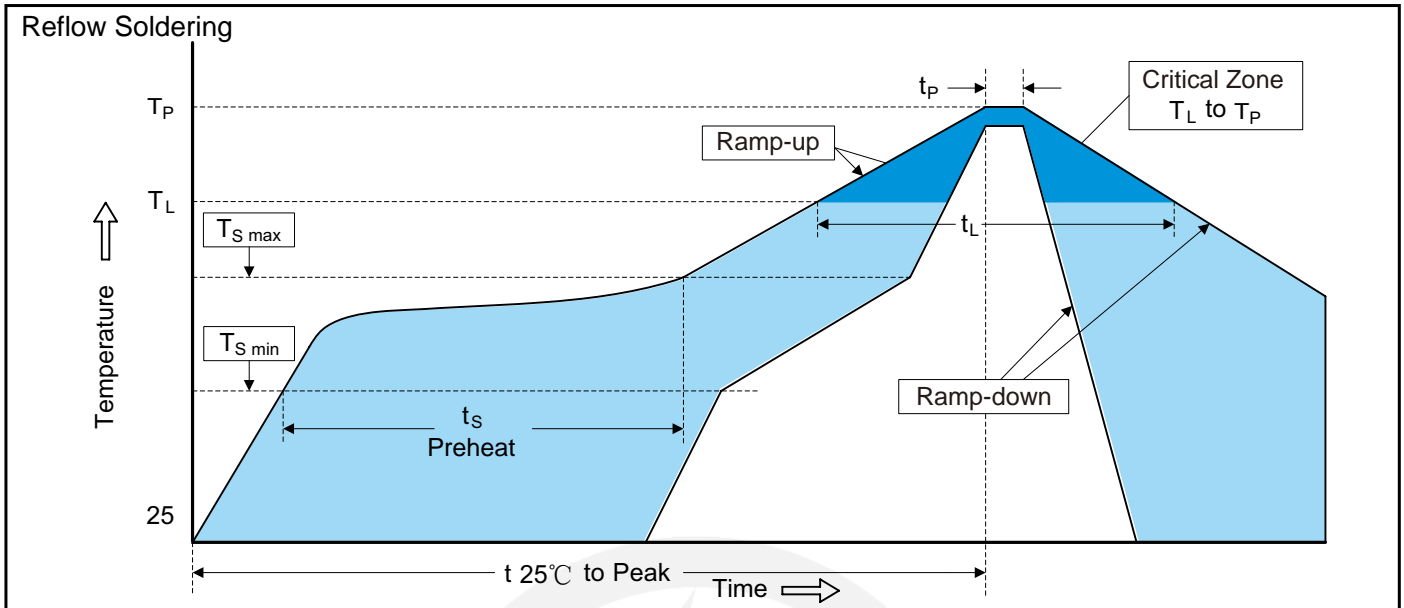

Recommended Conditions

Profile Feature	Pb-Free Assembly
Average ramp-up rate (T _L to T _P)	3°C/second max.
Preheat	
-Temperature Min (T _{S min})	150°C
-Temperature Max (T _{S max})	200°C
-Time (min to max) (t _s)	60-180 seconds
T _{S max} to T _L	
-Ramp-up Rate	3°C/second max.
Time maintained above:	
-Temperature (T _L)	217°C
-Time (t _L)	60-150 seconds
Peak Temperature (T _P)	260°C
Time within 5°C of actual Peak Temperature (t _p)	20-40 seconds
Ramp-down Rate	6°C/second max.
Time 25°C to Peak Temperature	8 minutes max.

Important Notice and Disclaimer

Leading-Tech reserves the right to make changes to this document and its products and specifications at any time without notice.

Customers should obtain and confirm the latest product information and specifications before final design, purchase or use.

Leading-Tech makes no warranty, representation or guarantee regarding the suitability of its products for any particular purpose, not does Leading-Tech assume any liability for application assistance or customer product design.

Leading-tech does not warrant or accept any liability with products which are purchase or used for any unintended or unauthorized application.

No license is granted by implication or otherwise under any intellectual property rights of Leading-Tech.

Leading-Tech products are not authorized for use as critical components in life support devices or systems without express written approval of Leading-tech.

Version Update Information

Series NO.	Enactment/Revision Date	Effective Date	Version	Revision content	Revision Reason	Revision Person	Note
01	2025.01.21	2025.01.21	3.0	New File	/	Ding	