

Transient Voltage Suppressors for ESD Protection

Features

- IEC61000-4-2 (ESD) $\pm 30\text{kV}$ (air),
 $\pm 30\text{kV}$ (contact)
- IEC61000-4-4 (EFT) 40A (5/50 μs)
- Peak power dissipation: 60W (8/20 μs)
- Protects one I/O line
- Low clamping voltage
- Working voltages : 5V
- Low leakage current
- Lead free in comply with EU RoHS 2011/65/EU directives

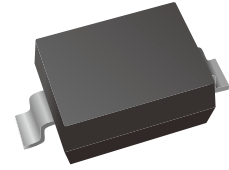

Mechanical Data

- Case: SOD-323
- Terminals: Tin plated, solderable perMIL-STD-750, method 2026

Applications

- High Speed Line :USB1.0/2.0, VGA, DVI, SDI,
- Serial and Parallel Ports
- Notebooks, Desktops, Servers
- Projection TV
- Cellular handsets and accessories
- Portable instrumentation
- Peripherals

Ordering Information

Part Number	Marking	Shipping	Reel
LTES05C01-TR3	3M or AC	3000PCS Tape&Reel	7 inches
LTES05C01-TR12	3M or AC	12000PCS Tape&Reel	13 inches

Absolute Maximum Ratings (T_A=25°C unless otherwise specified)

Symbol	Parameter	Value	Units
V _{ESD}	ESD per IEC 61000-4-2 (Contact)	± 30	kV
	ESD per IEC 61000-4-2 (Air)	± 30	
P _{PP}	Peak Pulse Power (8/20 μs)	60	W
T _{OPT}	Operating Temperature	-55~150	°C
T _{STG}	Storage Temperature	-55~150	°C

Electrical Characteristics ($T_A=25^\circ\text{C}$ unless otherwise specified)

Symbol	Parameter	Test Condition	Min	Typ	Max	Units
V_{RWM}	Reverse Working Voltage				5.0	V
V_{BR}	Reverse Breakdown Voltage	$I_T = 1\text{mA}$	5.6		7.8	V
I_R	Reverse Leakage Current	$V_{RWM} = 5\text{V}$			1.0	μA
V_C	Clamping Voltage	$I_{PP} = 5\text{A}$, $t_p = 8/20\mu\text{s}$			12.0	V
C_J	Junction Capacitance	$V_R = 0\text{V}$, $f = 1\text{MHz}$			18	pF

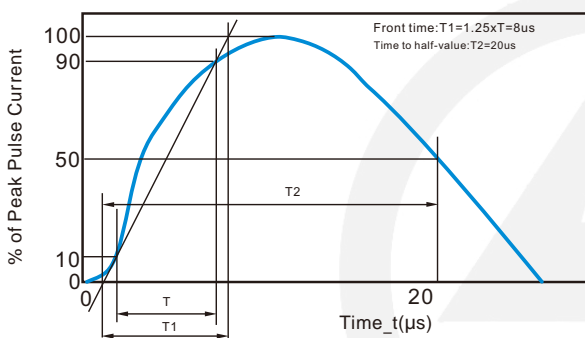
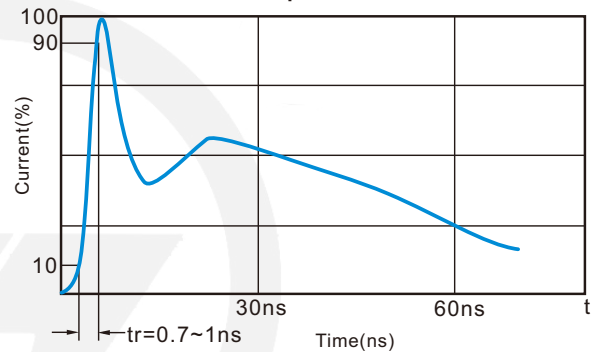
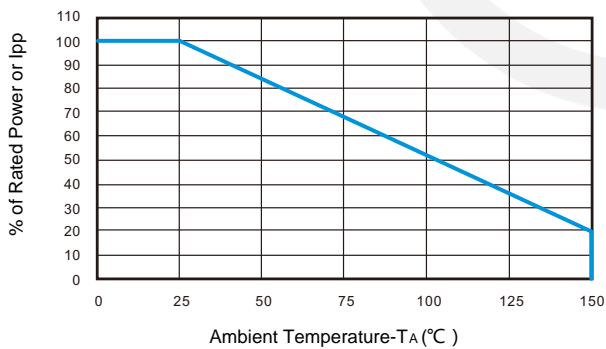
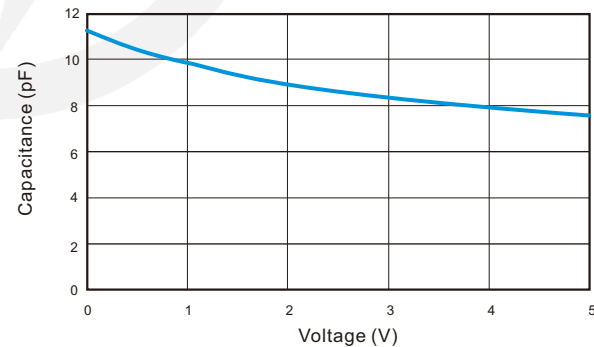
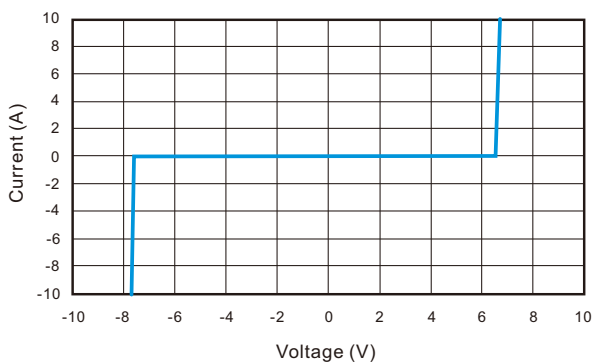
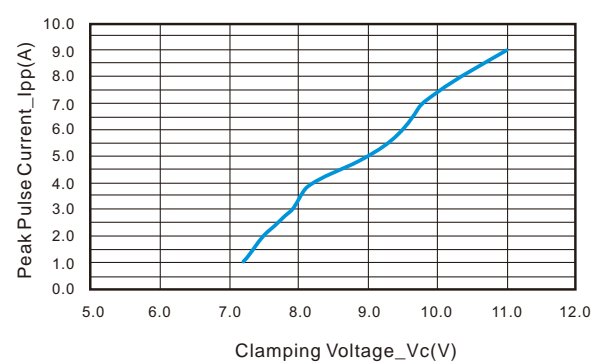
Characteristic Curves
Fig.1 8x20 μs Waveform per IEC61000-4-5

Fig.2 Contact Discharge Current Waveform per IEC 61000-4-2

Fig.3 Power Derating Curve

Fig.4 Voltage vs Capacitance

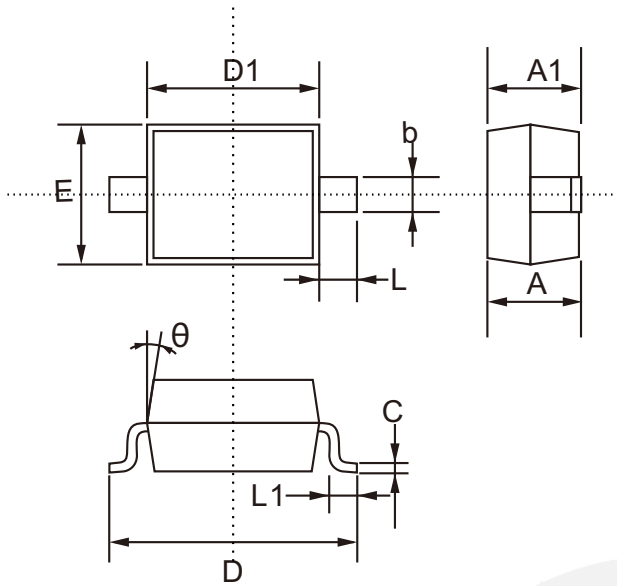
Fig.5 Voltage Sweeping

Fig.6 Clamping Voltage vs Peak Pulse Current($t_p=8/20\mu\text{s}$)



SOD-323 Package Outline

Unit: mm



SYMBOL	DIMENSIONS	
	MIN.	MAX.
A	0.800	1.100
A1	0.800	0.900
b	0.250	0.400
C	0.080	0.177
D	2.300	2.800
D1	1.400	1.800
E	1.150	1.400
L	0.475 TYP.	
θ	8°	

SOD-323 Suggested Pad Layout

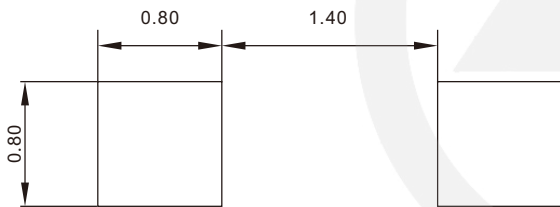

- Note:
1. Controlling dimension: in millimeters.
 2. General tolerance: $\pm 0.05\text{mm}$
 3. The pad layout is for reference purpose only.

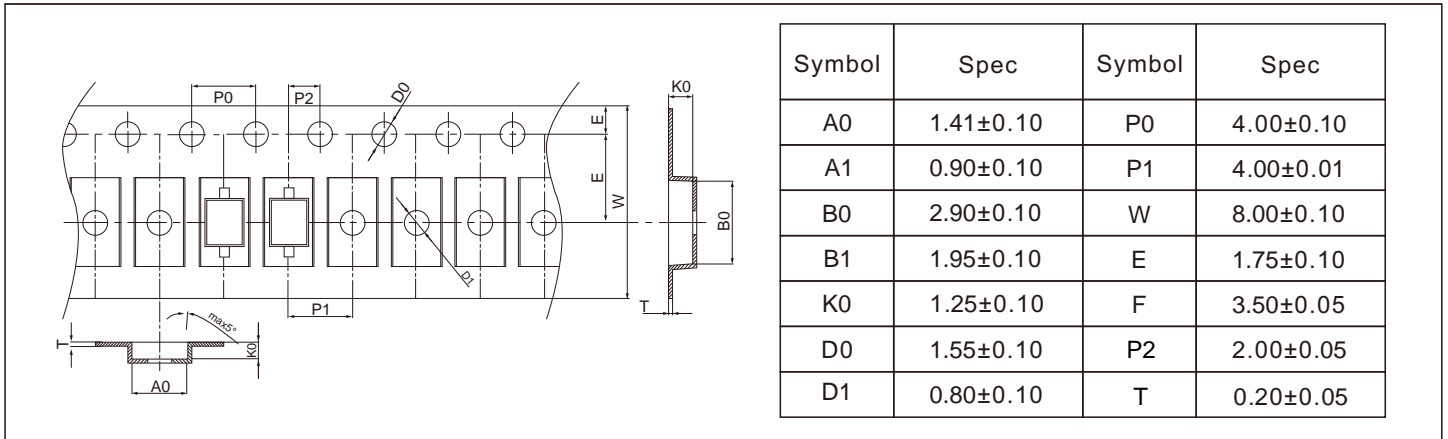
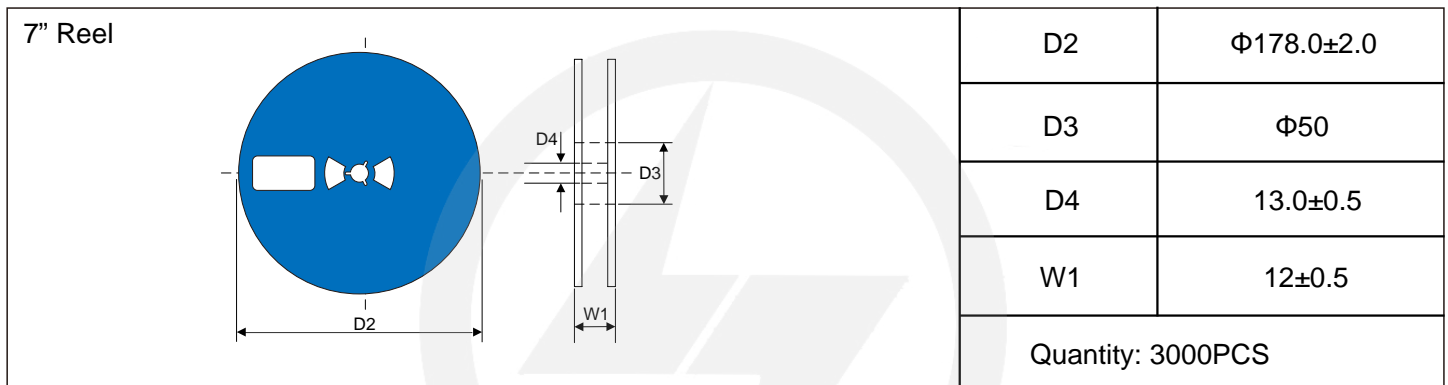
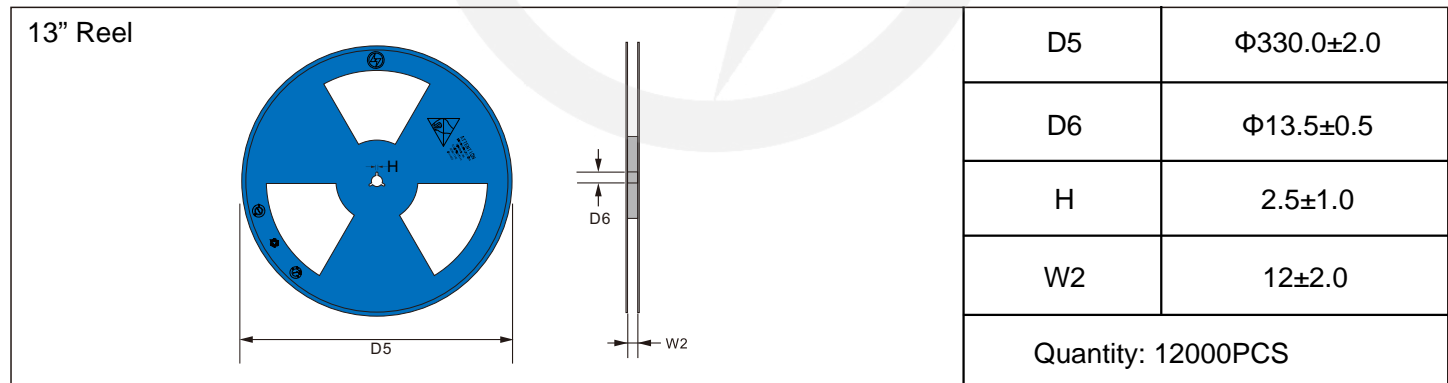
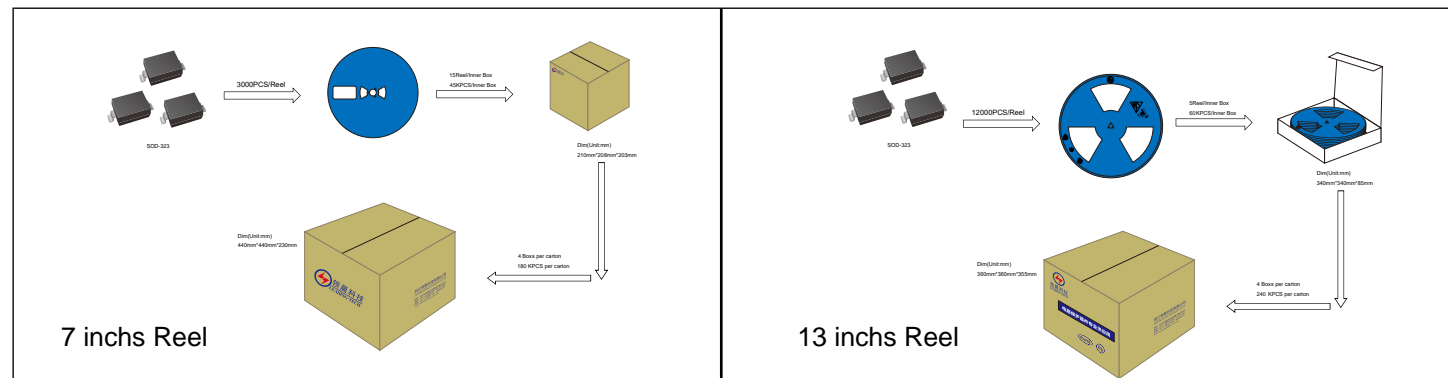
Carrier Tape Dimensions
Unit : mm

Reel Dimensions
Unit : mm

Reel Dimensions
Unit : mm

Packaging



Recommended Soldering Conditions



Recommended Conditions

Profile Feature	Pb-Free Assembly
Average ramp-up rate (T_L to T_P)	3°C/second max.
Preheat	
-Temperature Min ($T_{S\ min}$)	150°C
-Temperature Max ($T_{S\ max}$)	200°C
-Time (min to max) (t_s)	60-180 seconds
$T_{S\ max}$ to T_L	
-Ramp-up Rate	3°C/second max.
Time maintained above:	
-Temperature (T_L)	217°C
-Time (t_L)	60-150 seconds
Peak Temperature (T_P)	260°C
Time within 5°C of actual Peak Temperature (t_p)	20-40 seconds
Ramp-down Rate	6°C/second max.
Time 25°C to Peak Temperature	8 minutes max.

Important Notice and Disclaimer

Leading-Tech reserves the right to make changes to this document and its products and specifications at any time without notice.

Customers should obtain and confirm the latest product information and specifications before final design, purchase or use.

Leading-Tech makes no warranty, representation or guarantee regarding the suitability of its products for any particular purpose, not does Leading-Tech assume any liability for application assistance or customer product design.

Leading-tech does not warrant or accept any liability with products which are purchase or used for any unintended or unauthorized application.

No license is granted by implication or otherwise under any intellectual property rights of Leading-Tech.

Leading-Tech products are not authorized for use as critical components in life support devices or systems without express written approval of Leading-tech.

Version Update Information

Series NO.	Enactment/Revision Date	Effective Date	Version	Revision content	Revision Reason	Revision Person	Note
01	2024.08.18	2024.08.18	3.0	New File	/	Ding	
02	2025.06.12	2025.06.12	3.1	Update packaging information	/	Ding	