

## Bi-directional Ultra Low Capacitance TVS Array

### Features

- IEC61000-4-2 (ESD)  $\pm 30\text{kV}$  (air),  $\pm 30\text{kV}$  (contact)
- IEC61000-4-4 (EFT) 40A (5/50ns)
- IEC61000-4-5 (Lightning) 20A (8/20us)
- Protects one I/O line (bidirectional)
- Low clamping voltage
- Working voltages :3.3V
- Low leakage current
- Response Time is < 1 ns
- Lead free in comply with EU RoHS 2011/65/EU directives

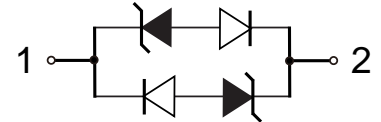
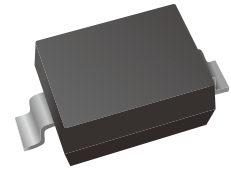

### Mechanical Data

- Case:SOD-323
- Flammability Rating: UL 94V-0

### Applications

- Cell Phone Handsets and Accessories
- Microprocessor based equipment
- Personal Digital Assistants (PDA's)
- Notebooks, Desktops, and Servers
- Portable Instrumentation
- Peripherals
- USB Interface

### Ordering Information

Part Number	Marking	Shipping	Reel
LTES03C01LG-TR3	CC	3000PCS Tape&Reel	7 inches
LTES03C01LG-TR12	CC	12000PCS Tape&Reel	13 inches

### Absolute Maximum Rating

Symbol	Parameter	Value	Unit
$V_{ESD}$	ESD per IEC 61000-4-2 (Air)	$\pm 30$	kV
	ESD per IEC 61000-4-2 (Contact)	$\pm 30$	
$P_{PP}$	Peak Pulse Power (8/20 $\mu$ s)	350	W
$T_{OPT}$	Operating Temperature	-55/+150	$^{\circ}$ C
$T_{STG}$	Storage Temperature	-55/+150	$^{\circ}$ C
$T_L$	Lead Soldering Temperature	260	$^{\circ}$ C

### Electrical Characteristics (TA=25 $^{\circ}$ C unless otherwise specified)

Part Number	Device Marking	$V_{RWM}$ (V) Max	$V_B@1mA$ (V) Min	$V_C@1A$ (V) Max	$V_C@I_{pp}^{*1}$ (V)		$V_C@I_{pp}^{*1}$ (V)		$I_R$ ( $\mu$ A) Max	$C_T^{*2}$ (pF) Typ.
					Max	$I_{pp}$ (A)	Max	$I_{pp}$ (A)		
LTES03C01LG	CC	3.3	4.0	7.0	13.9	8	20.0	20	5	0.8

\*1 Surge Pulse waveform tp=8/20 $\mu$ s

\*2 Capacitance @  $V_R=0V, f=1MHz$

### Characteristic Curves

Fig.1 8x20 $\mu$ s Pulse Waveform per IEC 61000-4-5

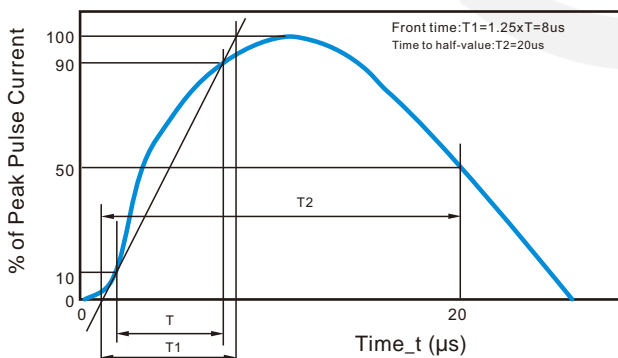

Fig.2 Contact Discharge Current Waveform per IEC 61000-4-2

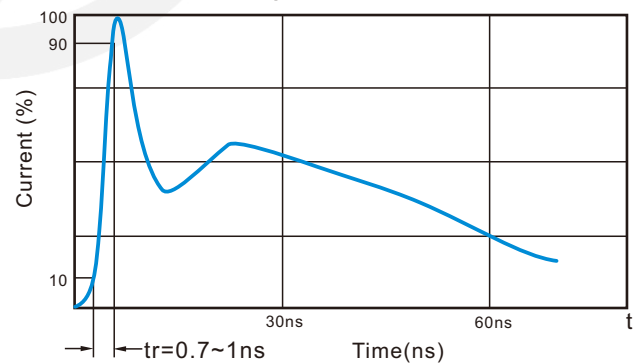

Fig.3 Voltage vs Capacitance

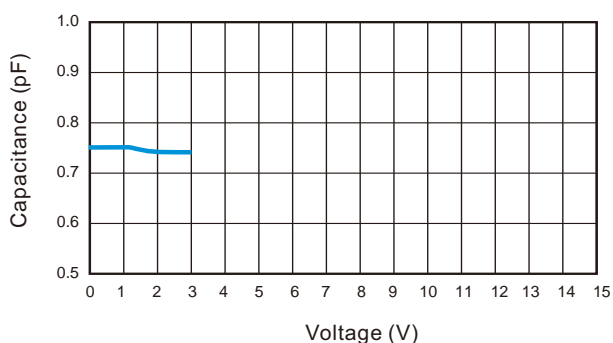
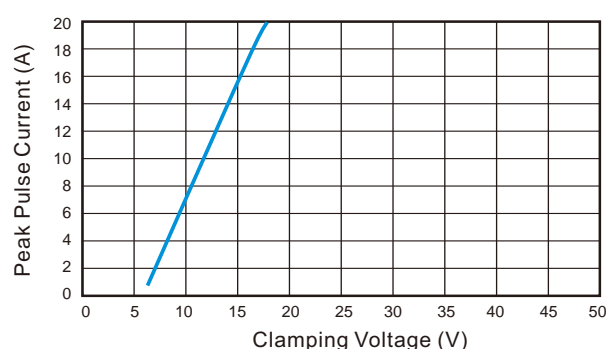

Fig.4 Clamping Voltage vs Peak Pulse Current





SOD-323 Package Outline

Unit: mm

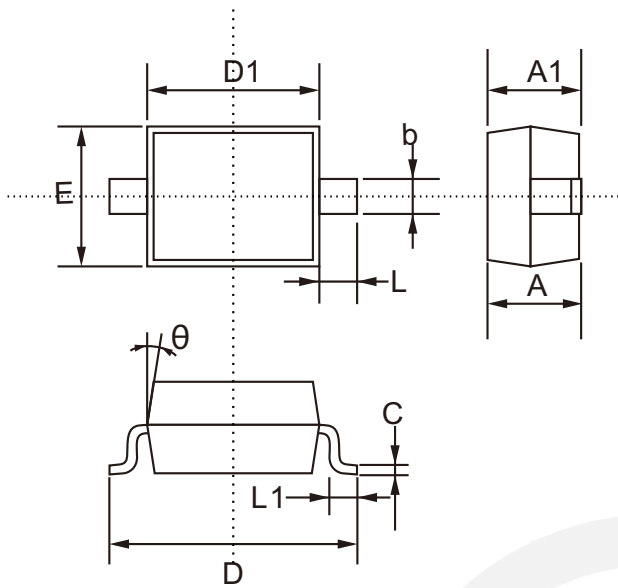

SYMBOL	DIMENSIONS	
	MIN.	MAX.
A	0.800	1.100
A1	0.800	0.900
b	0.250	0.400
C	0.080	0.177
D	2.300	2.800
D1	1.400	1.800
E	1.150	1.400
L1	0.100	0.400
L	0.475 TYP.	
theta	8°	

SOD-323 Suggested Pad Layout

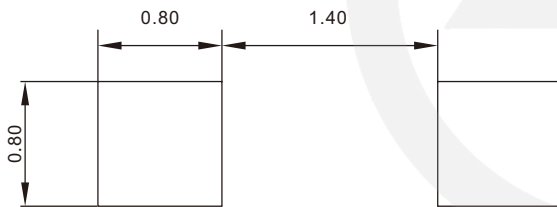

- Note:
1. Controlling dimension: in millimeters.
  2. General tolerance:  $\pm 0.05\text{mm}$
  3. The pad layout is for reference purpose only.

**Carrier Tape Dimensions**

Unit : mm

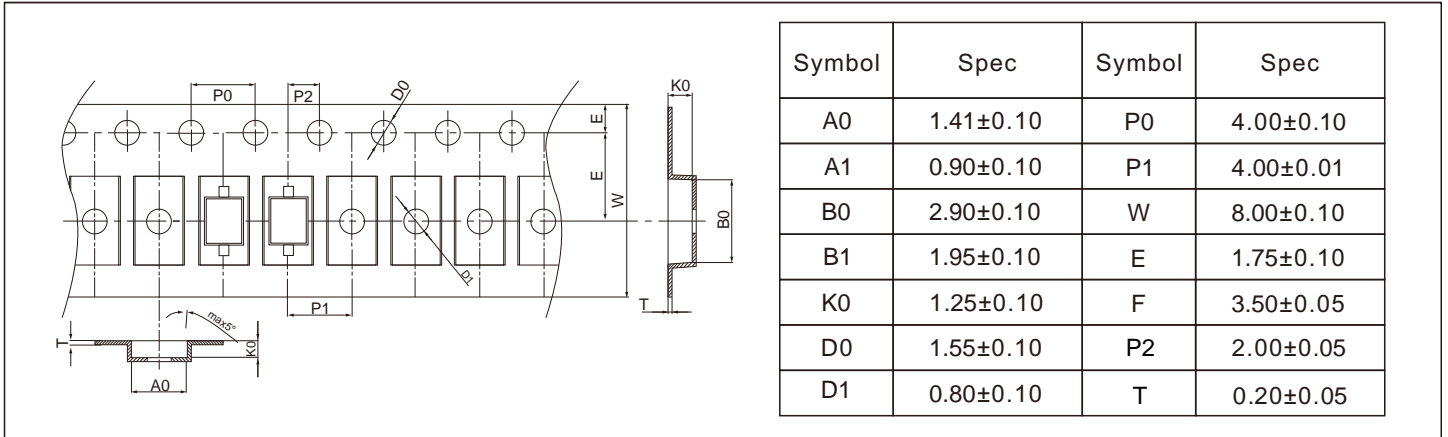

**Reel Dimensions**

Unit : mm

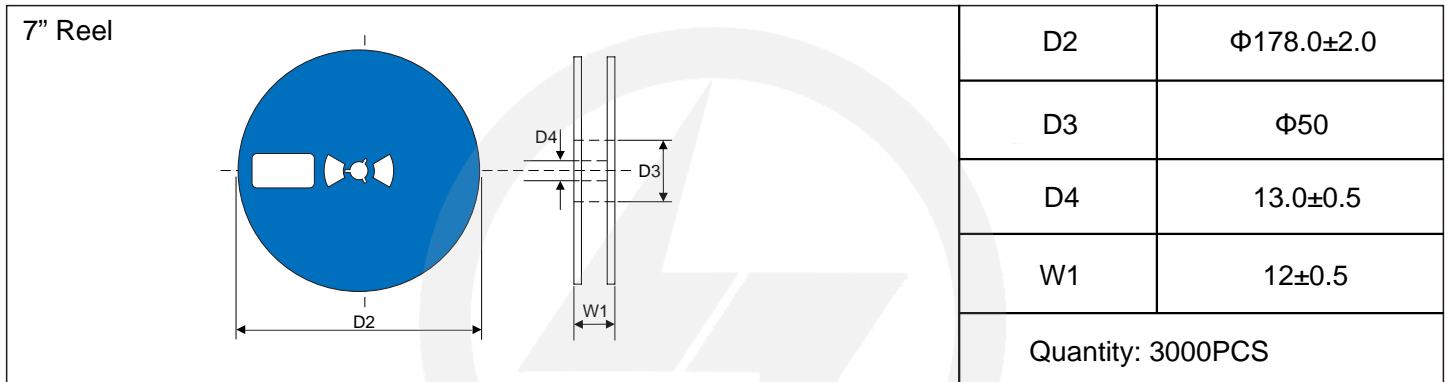

**Reel Dimensions**

Unit : mm

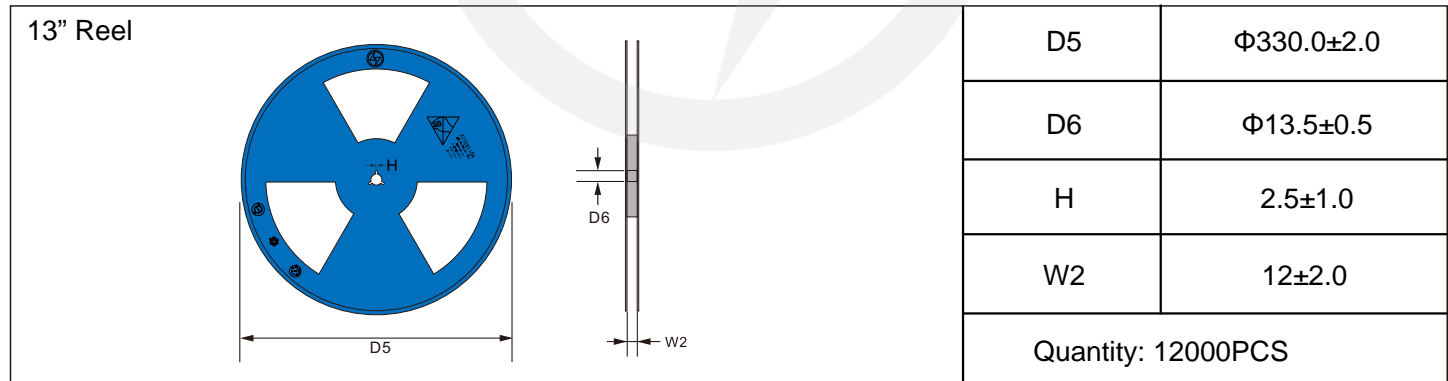

**Packaging**

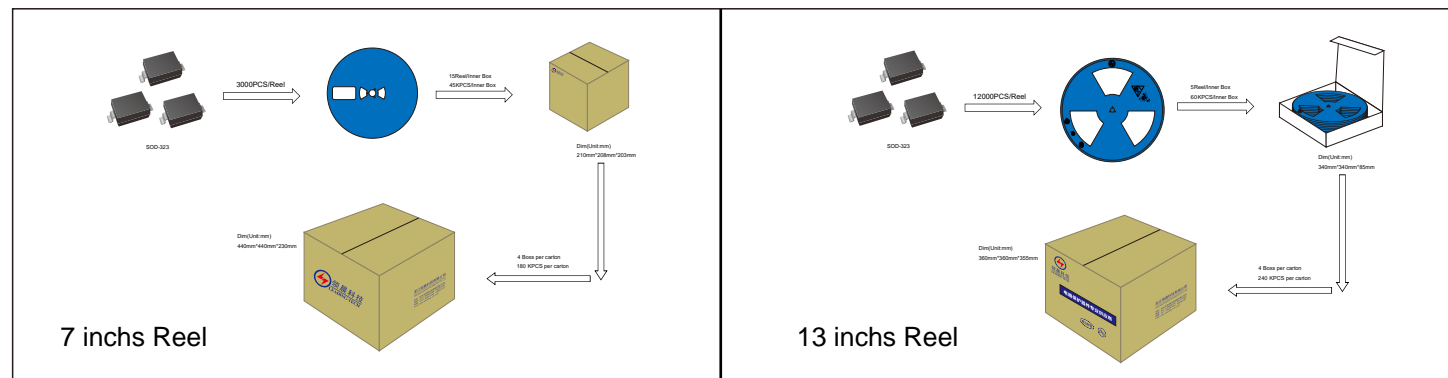



Recommended Soldering Conditions



Recommended Conditions

Profile Feature	Pb-Free Assembly
Average ramp-up rate (T <sub>L</sub> to T <sub>P</sub> )	3°C/second max.
Preheat	
-Temperature Min (T <sub>S min</sub> )	150°C
-Temperature Max (T <sub>S max</sub> )	200°C
-Time (min to max) (t <sub>s</sub> )	60-180 seconds
T <sub>S max</sub> to T <sub>L</sub>	
-Ramp-up Rate	3°C/second max.
Time maintained above:	
-Temperature (T <sub>L</sub> )	217°C
-Time (t <sub>L</sub> )	60-150 seconds
Peak Temperature (T <sub>P</sub> )	260°C
Time within 5°C of actual Peak Temperature (t <sub>p</sub> )	20-40 seconds
Ramp-down Rate	6°C/second max.
Time 25°C to Peak Temperature	8 minutes max.

## Important Notice and Disclaimer

Leading-Tech reserves the right to make changes to this document and its products and specifications at any time without notice.

Customers should obtain and confirm the latest product information and specifications before final design, purchase or use.

Leading-Tech makes no warranty, representation or guarantee regarding the suitability of its products for any particular purpose, not does Leading-Tech assume any liability for application assistance or customer product design.

Leading-tech does not warrant or accept any liability with products which are purchase or used for any unintended or unauthorized application.

No license is granted by implication or otherwise under any intellectual property rights of Leading-Tech.

Leading-Tech products are not authorized for use as critical components in life support devices or systems without express written approval of Leading-tech.

## Version Update Information

Series NO.	Enactment/Revision Date	Effective Date	Version	Revision content	Revision Reason	Revision Person	Note
01	2024.03.16	2024.03.16	3.0	New File	/	Ding	
02	2025.06.16	2025.06.16	3.1	Update packaging information	/	Ding	