

Transient Voltage Suppressors

Features

- IEC61000-4-2 Level 4 ESD Protection
- Protects one directional I/O line
- Low clamping voltage
- Working voltages : 36V
- Low leakage current
- Lead free in comply with EU RoHS 2011/65/EU directives



Mechanical Data

- Case:SOD-523
- Flammability Rating: UL 94V-0

Applications

- Microprocessor based equipment
- Personal Digital Assistants (PDA's)
- Notebooks, Desktops, and Servers
- Portable Instrumentation
- Peripherals
- LED backlight

Ordering Information

Part Number	Marking	Shipping	Reel
LTE5L36A01-TR3	5Y or ZS	3000PCS Tape&Reel	7 inches
LTE5L36A01-TR10	5Y or ZS	10000PCS Tape&Reel	7 inches

Absolute Maximum Rating

Symbol	Parameter	Value	Unit
V_{ESD}	ESD per IEC 61000-4-2 (Air)	±25	kV
	ESD per IEC 61000-4-2 (Contact)	±20	
P_{PP}	Peak Pulse Power	55	W
T_{OPT}	Operating Temperature	-55~125	°C
T_{STG}	Storage Temperature	-55~150	°C

These ratings are limiting values above which the serviceability of the diode may be impaired.

Note1: FR-5=1.0x0.75x0.62 in.

Electrical Characteristics (TA=25°C unless otherwise specified)

Symbol	Parameter	Test Condition	Min	Typ	Max	Unit
V_{RWM}	Reverse Working Voltage				36	V
V_{BR}	Reverse Breakdown Voltage	$I_T = 1mA$	40			V
I_R	Reverse Leakage Current	$V_{RWM} = 36V$			5	μA
V_C	Clamping Voltage	$I_{PP} = 1A, t_p = 8/20\mu s$			55	V
C_J	Junction Capacitance	$V_R = 0V, f = 1MHz$			28	pF

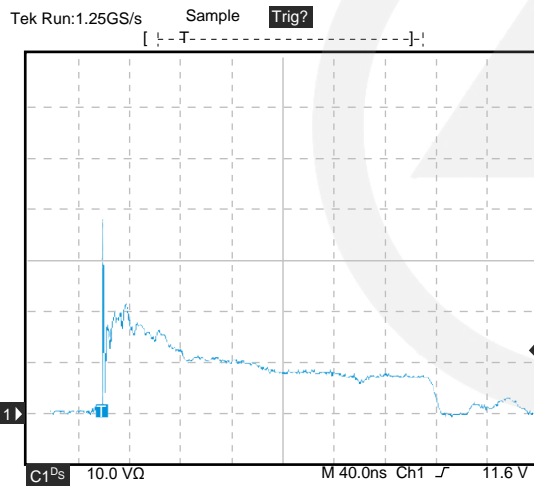
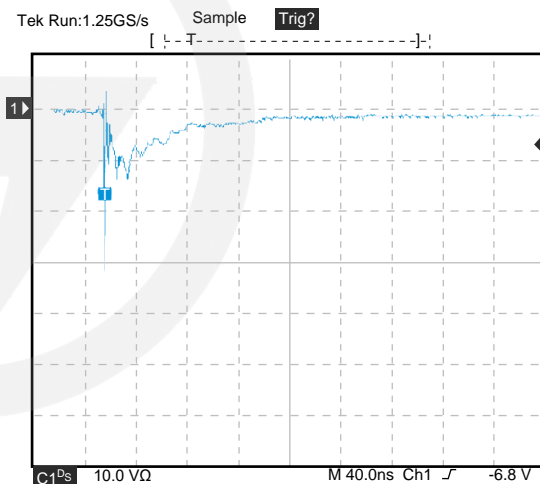
Characteristic Curves
Fig.1 ESD Clamping Voltage Screenshot
Positive 8 kV contact per IEC 61000-4-2

Fig.2 ESD Clamping Voltage Screenshot
Negative 8 kV contact per IEC 61000-4-2

SOD-523 Package Outline

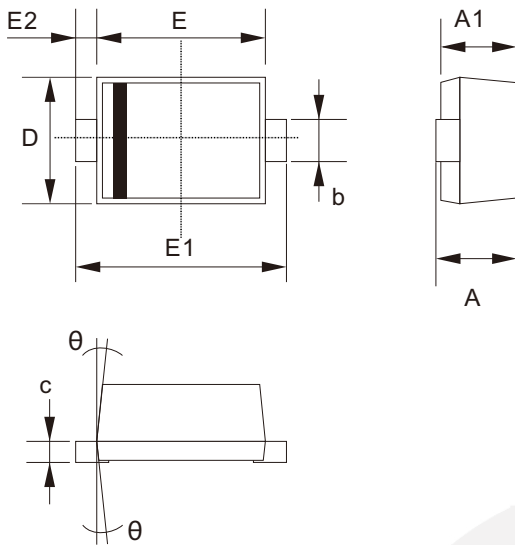
Unit: mm



SYMBOL	DIMENSIONS	
	MIN.	MAX.
A	0.500	0.770
A1	0.500	0.700
b	0.250	0.380
c	0.070	0.200
D	0.700	0.900
E	1.100	1.300
E1	1.500	1.700
E2	0.200 REF	
θ	7° REF	

SOD-523 Suggested Pad Layout

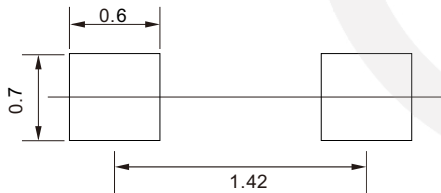

- Note:
1. Controlling dimension: in millimeters.
 2. General tolerance: ± 0.05 mm.
 3. The pad layout is for reference purposes only.

Carrier Tape Dimensions

Unit : mm

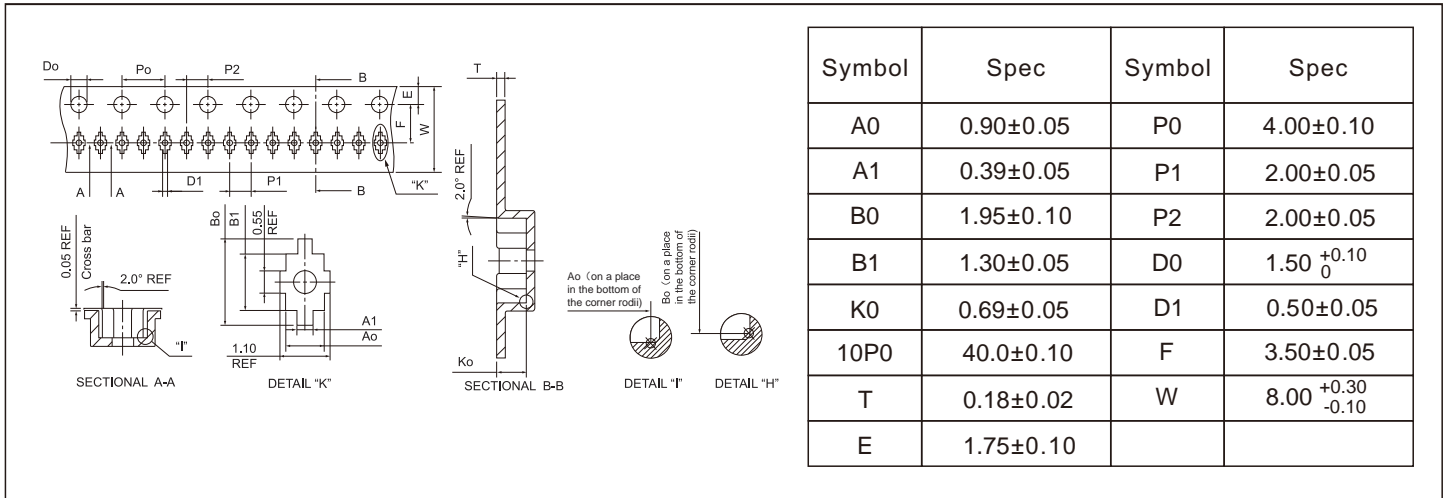

Reel Dimensions

Unit : mm

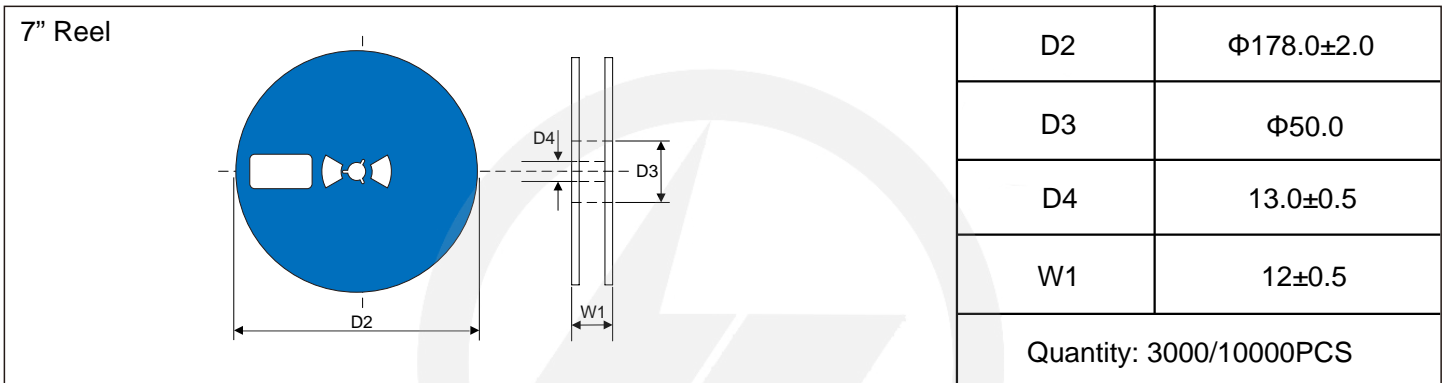

Packaging

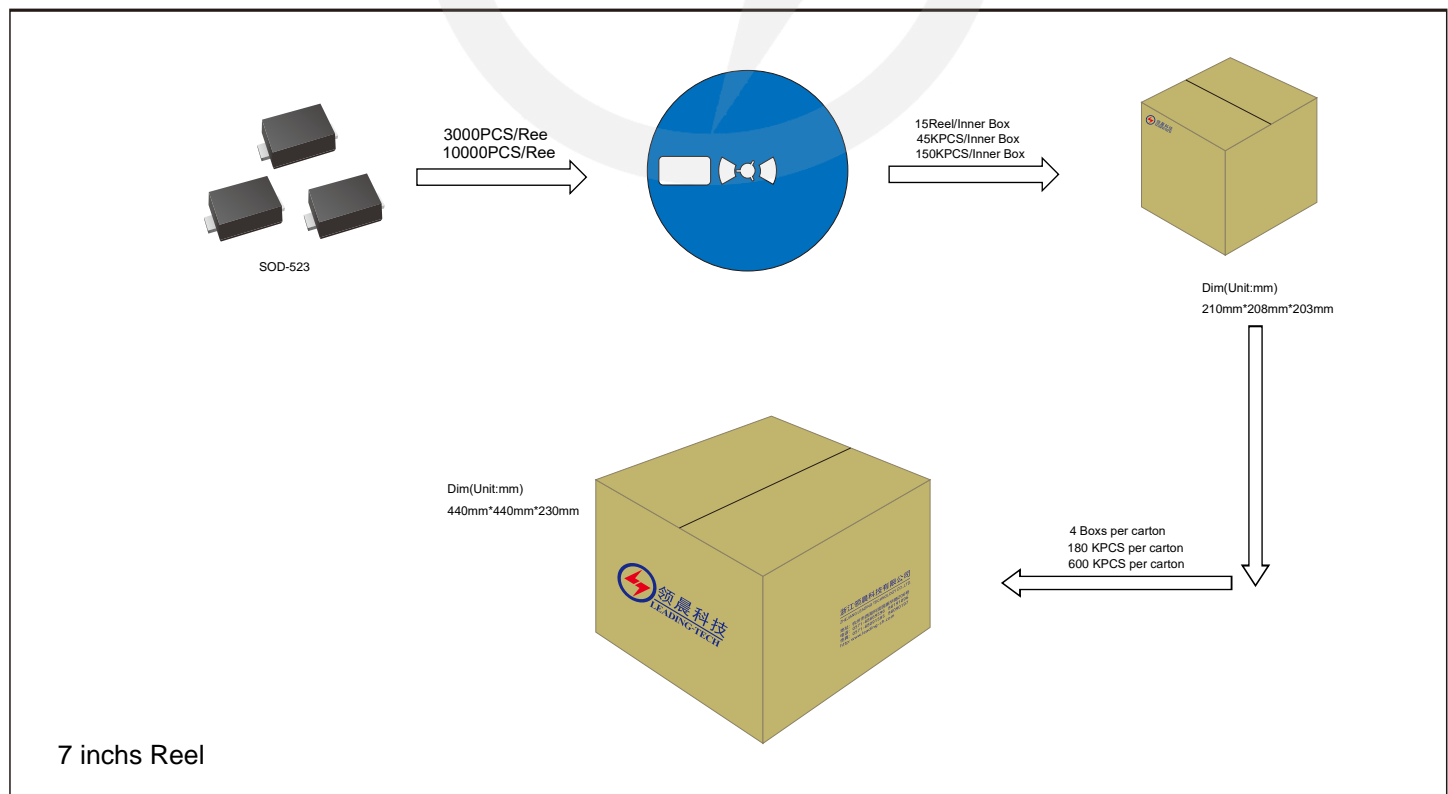



Recommended Soldering Conditions

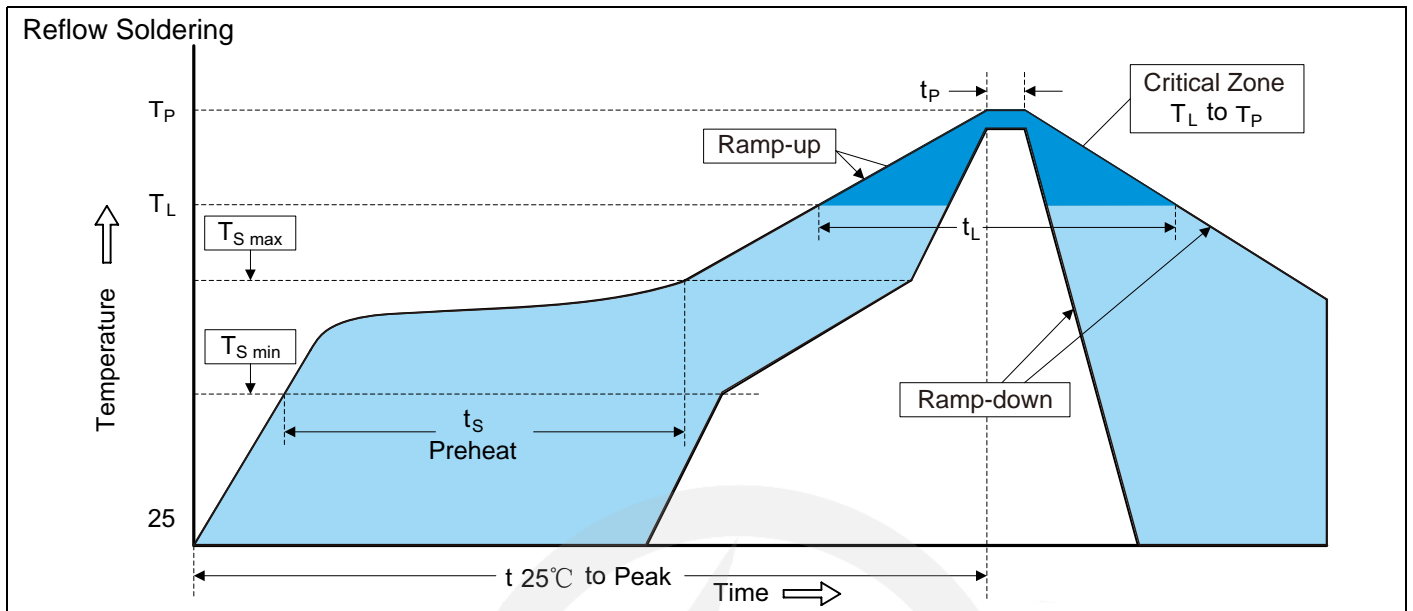

Recommended Conditions

Profile Feature	Pb-Free Assembly
Average ramp-up rate (T _L to T _P)	3°C/second max.
Preheat	
-Temperature Min (T _{S min})	150°C
-Temperature Max (T _{S max})	200°C
-Time (min to max) (t _s)	60-180 seconds
T _{S max} to T _L	
-Ramp-up Rate	3°C/second max.
Time maintained above:	
-Temperature (T _L)	217°C
-Time (t _L)	60-150 seconds
Peak Temperature (T _P)	260°C
Time within 5°C of actual Peak Temperature (t _p)	20-40 seconds
Ramp-down Rate	6°C/second max.
Time 25°C to Peak Temperature	8 minutes max.

Important Notice and Disclaimer

Leading-Tech reserves the right to make changes to this document and its products and specifications at any time without notice.

Customers should obtain and confirm the latest product information and specifications before final design, purchase or use.

Leading-Tech makes no warranty, representation or guarantee regarding the suitability of its products for any particular purpose, nor does Leading-Tech assume any liability for application assistance or customer product design.

Leading-tech does not warrant or accept any liability with products which are purchase or used for any unintended or unauthorized application.

No license is granted by implication or otherwise under any intellectual property rights of Leading-Tech.

Leading-Tech products are not authorized for use as critical components in life support devices or systems without express written approval of Leading-tech.

Version Update Information

Series NO.	Enactment/Revision Date	Effective Date	Version	Revision content	Revision Reason	Revision Person	Note
01	2024.4.5	2024.4.5	3.0	New File	/	Ding	