

ESD Protection Diodes

Features

- IEC 61000-4-2 (ESD)
 - ±30kV Contact Discharge
 - ±30kV Air Discharge
- 150W Peak pulse Power (8/20us)
- IEC 61000-4-4 EFT Protection
 - 40A (5/50ns)
- Protects one directional I/O line
- Transient protection for high-speed data lines
- Low clamping voltage
- Low leakage current
- Lead free in comply with EU RoHS 2011/65/EU directives

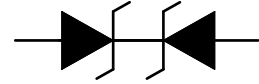
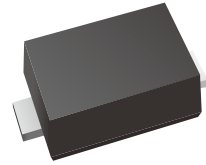

Mechanical Data

- Case: SOD-523
- Flammability Rating: UL 94V-0
- Approx. Weight: 1.4mg
- Cell Phone Handsets and Accessories
- Microprocessor based equipment
- Personal Digital Assistants
- Notebooks / Desktops / Servers
- Portable Instrumentation
- Peripherals & Pagers

Ordering Information

Part Number	Marking	Shipping	Reel
LTE5L12C01-TR3	12C	3000PCS Tape&Reel	7 inchs
LTE5L12C01-TR10	12C	10000PCS Tape&Reel	7 inchs



Absolute Maximum Rating

Over operating free-air temperature range (unless otherwise noted)

Parameters	Symbol	Min	Max	Unit
Peak pulse power (tp=8/20us)@25°C	P _{pk}		150	W
Peak pulse current (tp=8/20us)@25°C	I _{PP}		8	A
ESD (IEC61000-4-2 air discharge) @25°C	V _{ESD}		±30	kV
ESD (IEC61000-4-2 contact discharge) @25°C	V _{ESD}		±30	kV
Junction temperature	T _J		150	°C
Operating temperature	T _{OP}	-40	125	°C
Storage temperature	T _{STG}	-55	150	°C
Lead temperature	T _L		260	°C

Electrical Characteristics

At TA = 25°C unless otherwise noted

Parameter	Symbol	Conditions	Min	Typ	Max	Units
Reverse Stand-off Voltage	V _{RWM}				12	V
Reverse Breakdown Voltage	V _{BR}	I _T =1mA	13			V
Reverse Leakage Current	I _R	V _{RWM} =12V			0.1	uA
Clamping Voltage	V _C	I _{PP} =1A; tp=8/20us		16		V
Clamping Voltage	V _C	I _{PP} =8A; tp=8/20us		18		V
Junction Capacitance	C _J	I/O to GND; VR=0V; f=1MHz		8		pF

Characteristics Curve

Fig.1 Pulse rating curve

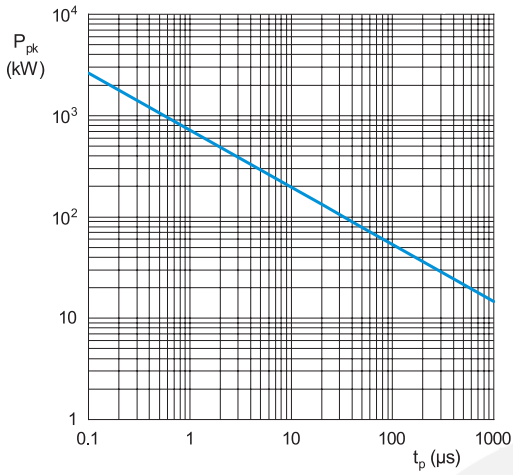

Fig.2 Peak pulse power derating curve

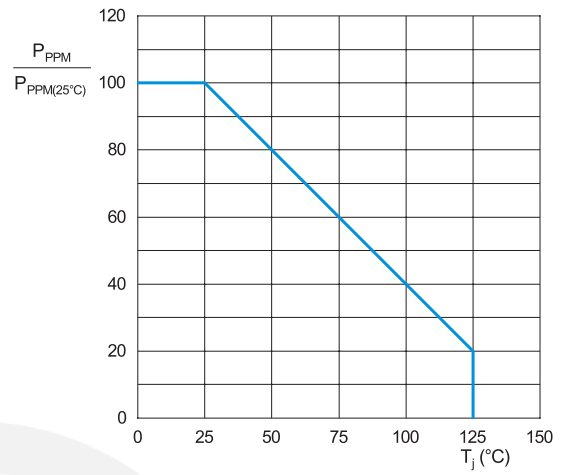

Fig.3 Pulse waveform

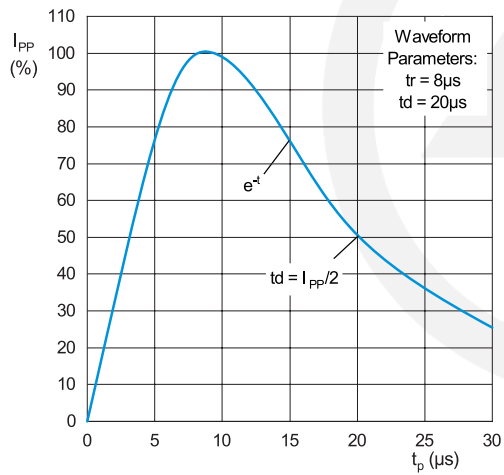
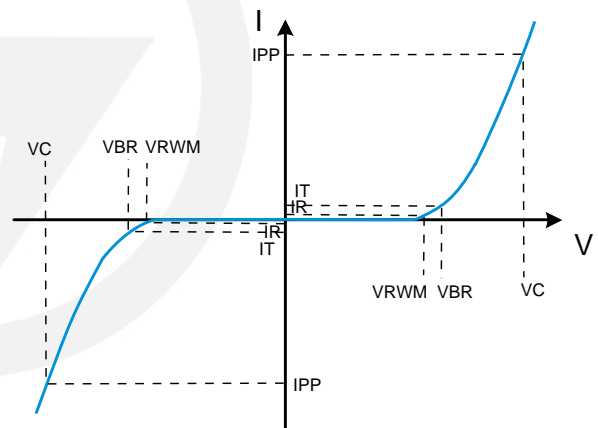

Fig.4 Parameters





SOD-523 Package Outline

Unit: mm

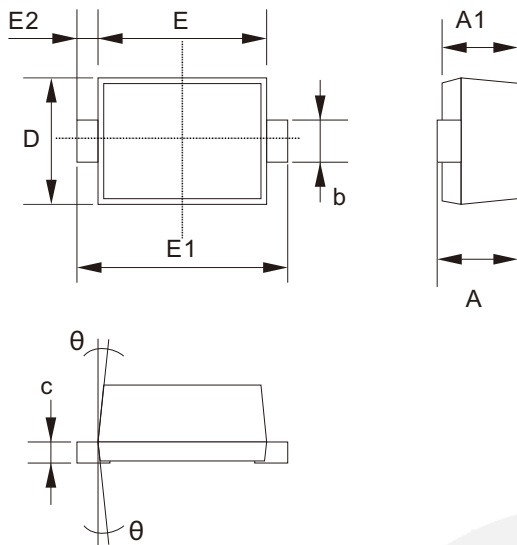

SYMBOL	DIMENSIONS	
	MIN.	MAX.
A	0.500	0.770
A1	0.500	0.700
b	0.250	0.380
c	0.070	0.200
D	0.700	0.900
E	1.100	1.300
E1	1.500	1.700
E2	0.200 REF	
θ	7° REF	

SOD-523 Suggested Pad Layout

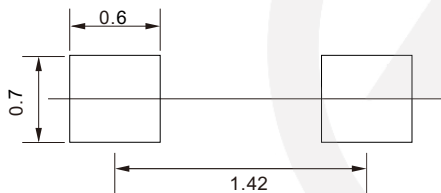

Note:

1. Controlling dimension: in millimeters.
2. General tolerance: ± 0.05 mm.
3. The pad layout is for reference purposes only.

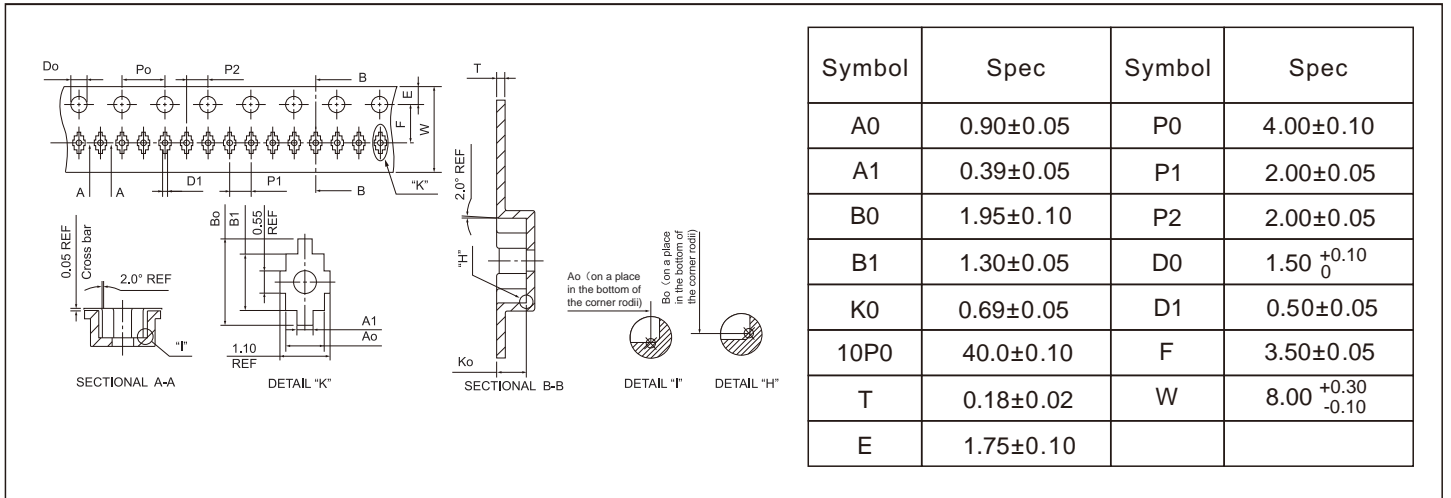
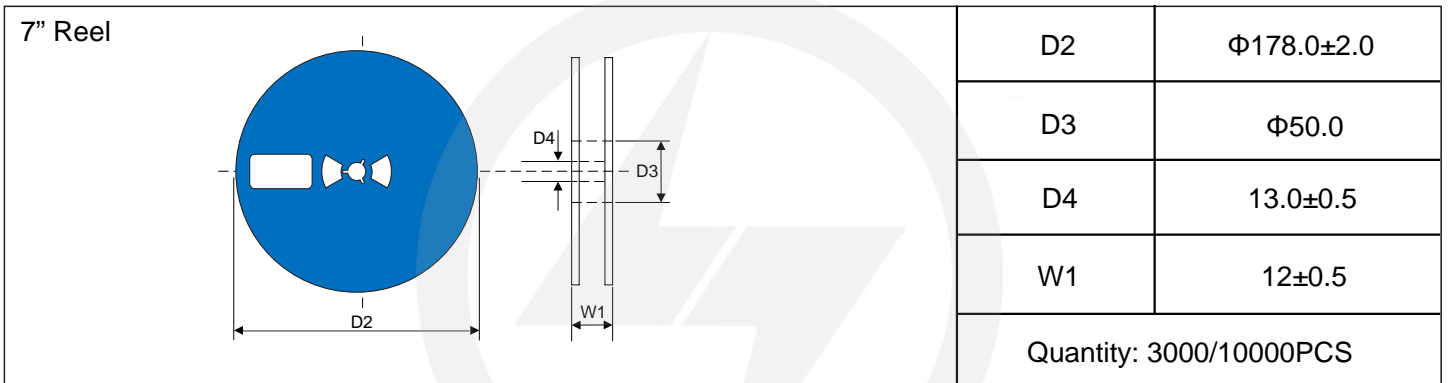
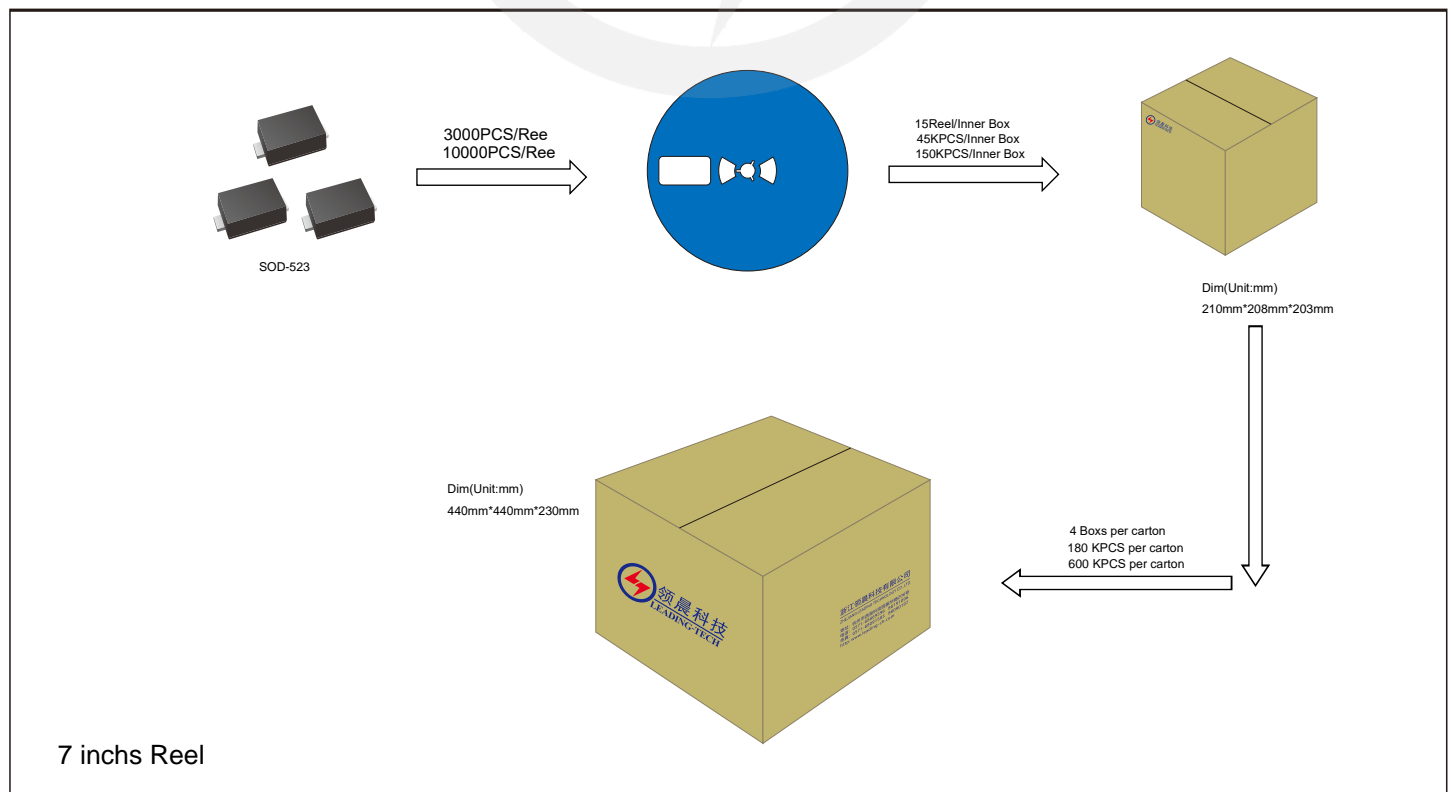
Carrier Tape Dimensions
Unit : mm

Reel Dimensions
Unit : mm

Packaging

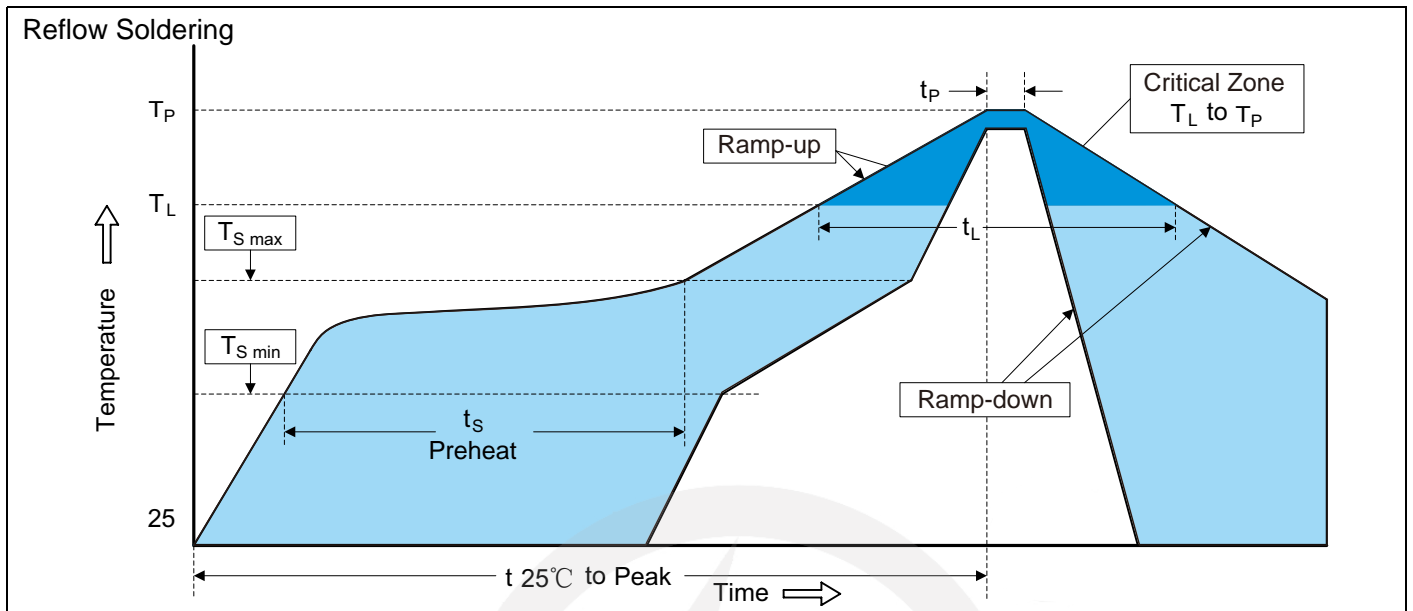

Recommended Soldering Conditions



Recommended Conditions

Profile Feature	Pb-Free Assembly
Average ramp-up rate (T_L to T_P)	3°C/second max.
Preheat -Temperature Min ($T_{S\ min}$) -Temperature Max ($T_{S\ max}$) -Time (min to max) (t_s)	150°C 200°C 60-180 seconds
$T_{S\ max}$ to T_L -Ramp-up Rate	3°C/second max.
Time maintained above: -Temperature (T_L) -Time (t_L)	217°C 60-150 seconds
Peak Temperature (T_P)	260°C
Time within 5°C of actual Peak Temperature (t_p)	20-40 seconds
Ramp-down Rate	6°C/second max.
Time 25°C to Peak Temperature	8 minutes max.

Important Notice and Disclaimer

Leading-Tech reserves the right to make changes to this document and its products and specifications at any time without notice.

Customers should obtain and confirm the latest product information and specifications before final design, purchase or use.

Leading-Tech makes no warranty, representation or guarantee regarding the suitability of its products for any particular purpose, not does Leading-Tech assume any liability for application assistance or customer product design.

Leading-Tech does not warrant or accept any liability with products which are purchase or used for any unintended or unauthorized application.

No license is granted by implication or otherwise under any intellectual property rights of Leading-Tech.

Leading-Tech products are not authorized for use as critical components in life support devices or systems without express written approval of Leading-tech.

Version Update Information

Series NO.	Enactment/Revision Date	Effective Date	Version	Revision content	Revision Reason	Revision Person	Note
01	2024.09.27	2024.09.27	3.0	New file	/	Ding	
02	2026.01.29	2026.01.29	3.1	Add weight	/	Ding	