

## Low Capacitance Bidirectional TVS/ESD Protection Diode

### Features

- ESD per IEC 61000-4-2 ±30 kV (Contact)
- ESD per IEC 61000-4-2 ±30 kV (Air)
- IEC61000-4-4 (EFT) 40A (5/50ns)
- Peak power dissipation: 400W (8/20μs)
- Protects one Vcc or data line
- Low clamping voltage
- Working voltages : 5V
- Low leakage current
- Low capacitance
- Lead free in comply with EU RoHS 2011/65/EU directives



### Mechanical Data

- Case:SOD-523
- Flammability Rating: UL 94V-0

### Applications

- Cell Phone Handsets and Accessories
- Microprocessor based equipment
- Personal Digital Assistants (PDA's)
- Notebooks, Desktops, and Servers
- Portable Instrumentation
- Networking and Telecom
- Serial and Parallel Ports
- Peripherals

### Ordering Information

Part Number	Marking	Shipping	Reel
LTE5L05C01G-TR3	OC	3000PCS Tape&Reel	7 inches
LTE5L05C01G-TR10	OC	10000PCS Tape&Reel	7 inches

### Absolute Maximum Rating (TA=25°C unless otherwise noted)

Symbol	Parameter	Value	Units
V <sub>ESD</sub>	ESD per IEC 61000-4-2 (Contact)	±30	kV
	ESD per IEC 61000-4-2 (Air)	±30	
P <sub>PP</sub>	Peak Pulse Power (8/20μs)	400	W
T <sub>OPT</sub>	Operating Temperature	-55~150	°C
T <sub>STG</sub>	Storage Temperature	-55~150	°C

**Electrical Characteristics** (TA=25°C unless otherwise specified)

Symbol	Parameter	Test Condition	Min	Typ	Max	Units
$V_{RWM}$	Reverse Working Voltage				5.0	V
$V_{BR}$	Reverse Breakdown Voltage	$I_T = 1mA$	5.8		7.8	V
$I_R$	Reverse Leakage Current	$V_{RWM} = 5V$			1.0	$\mu A$
$V_C$	Clamping Voltage	$I_{PP} = 1A, t_p = 8/20\mu s$			9.8	V
$V_C$	Clamping Voltage	$I_{PP} = 20A, t_p = 8/20\mu s$		15	20	V
$C_J$	Junction Capacitance	$V_R = 0V, f = 1MHz$		33	40	pF

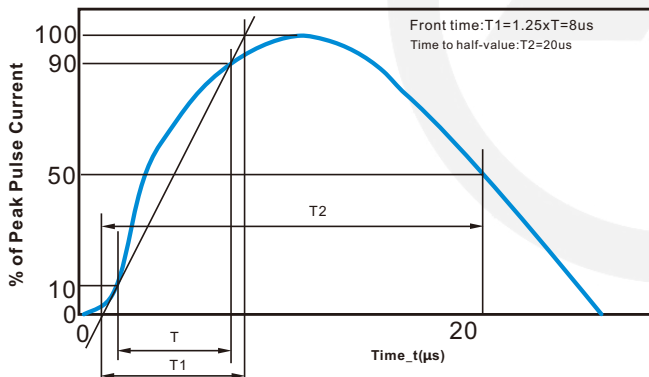
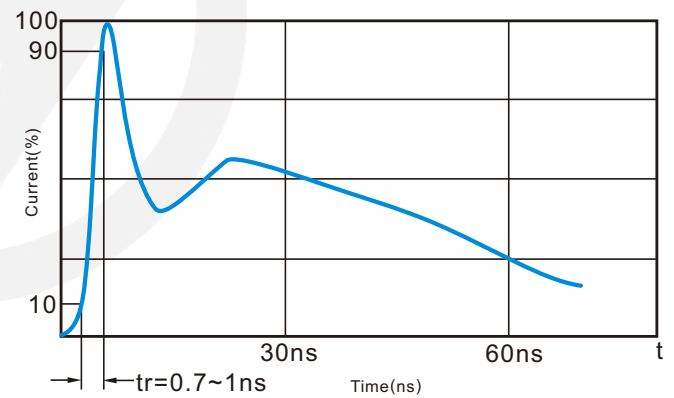
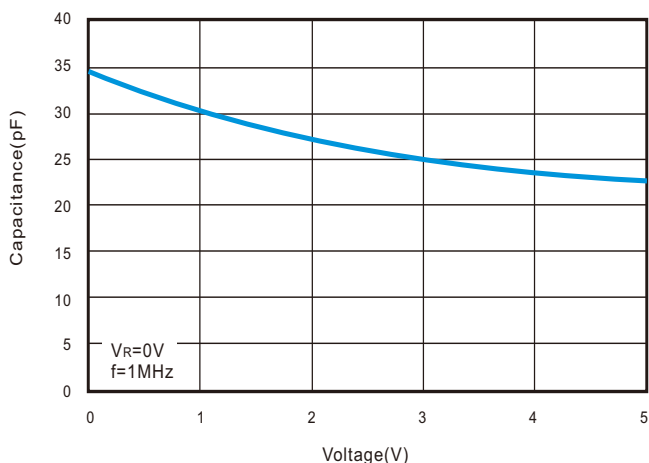
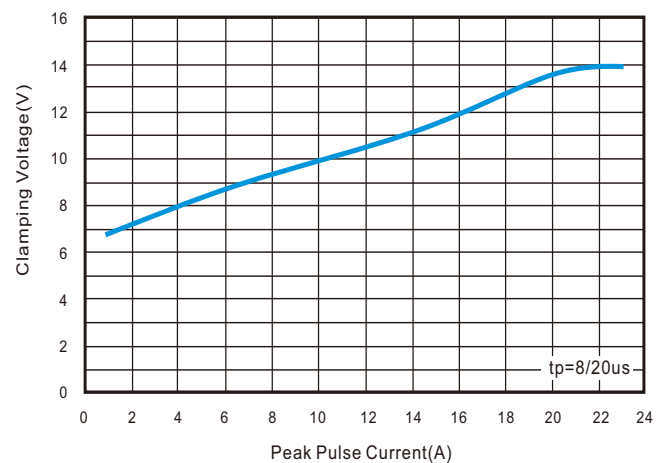
**Characteristics Curve**
**Fig.1 8x20us Waveform per IEC61000-4-5**

**Fig.2 Contact Discharge Current Waveform per IEC 61000-4-2**

**Fig.3 Voltage vs Capacitance**

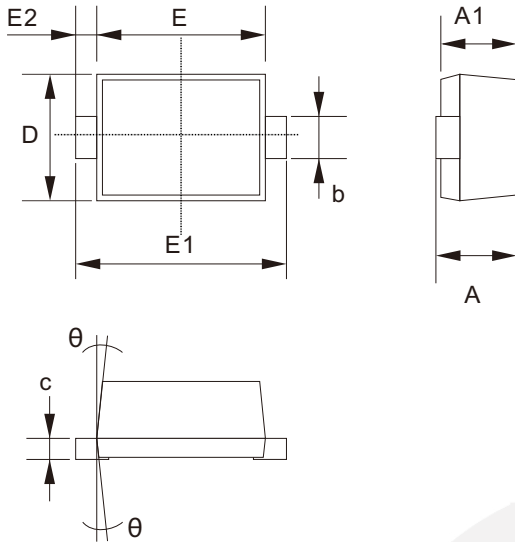
**Fig.4 Clamping Voltage vs Peak Pulse Current**

**SOD-523 Package Outline**

Unit: mm



SYMBOL	DIMENSIONS	
	MIN.	MAX.
A	0.500	0.770
A1	0.500	0.700
b	0.250	0.380
c	0.070	0.200
D	0.700	0.900
E	1.100	1.300
E1	1.500	1.700
E2	0.200 REF	
$\theta$	7° REF	

**SOD-523 Suggested Pad Layout**

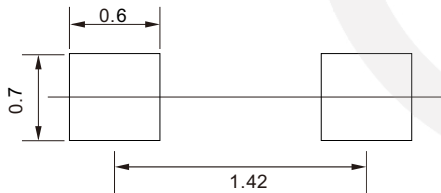

- Note:
1. Controlling dimension: in millimeters.
  2. General tolerance:  $\pm 0.05$  mm.
  3. The pad layout is for reference purposes only.

**Carrier Tape Dimensions**

Unit : mm

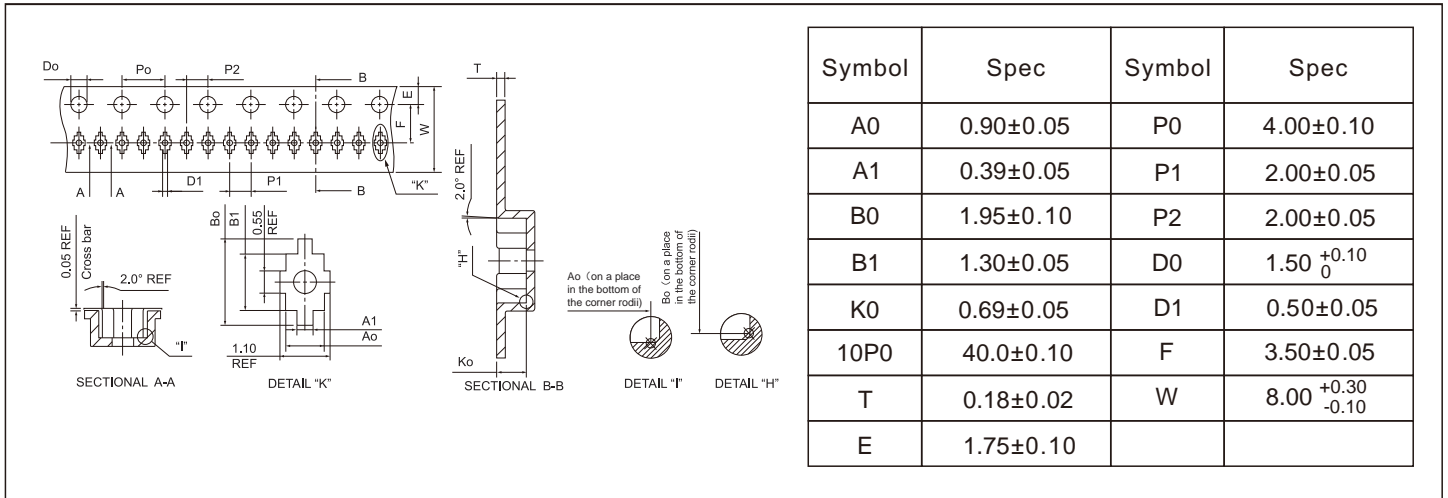

**Reel Dimensions**

Unit : mm

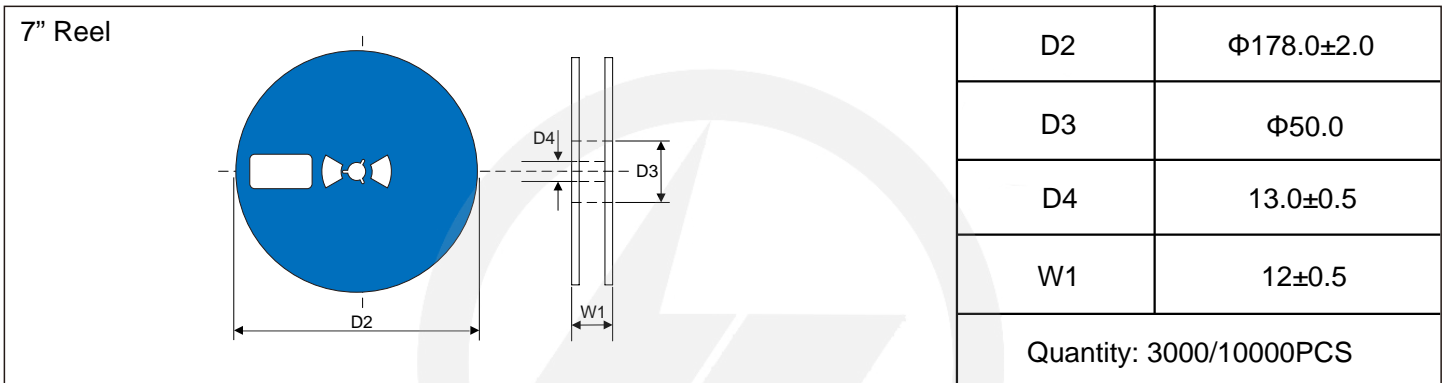

**Packaging**

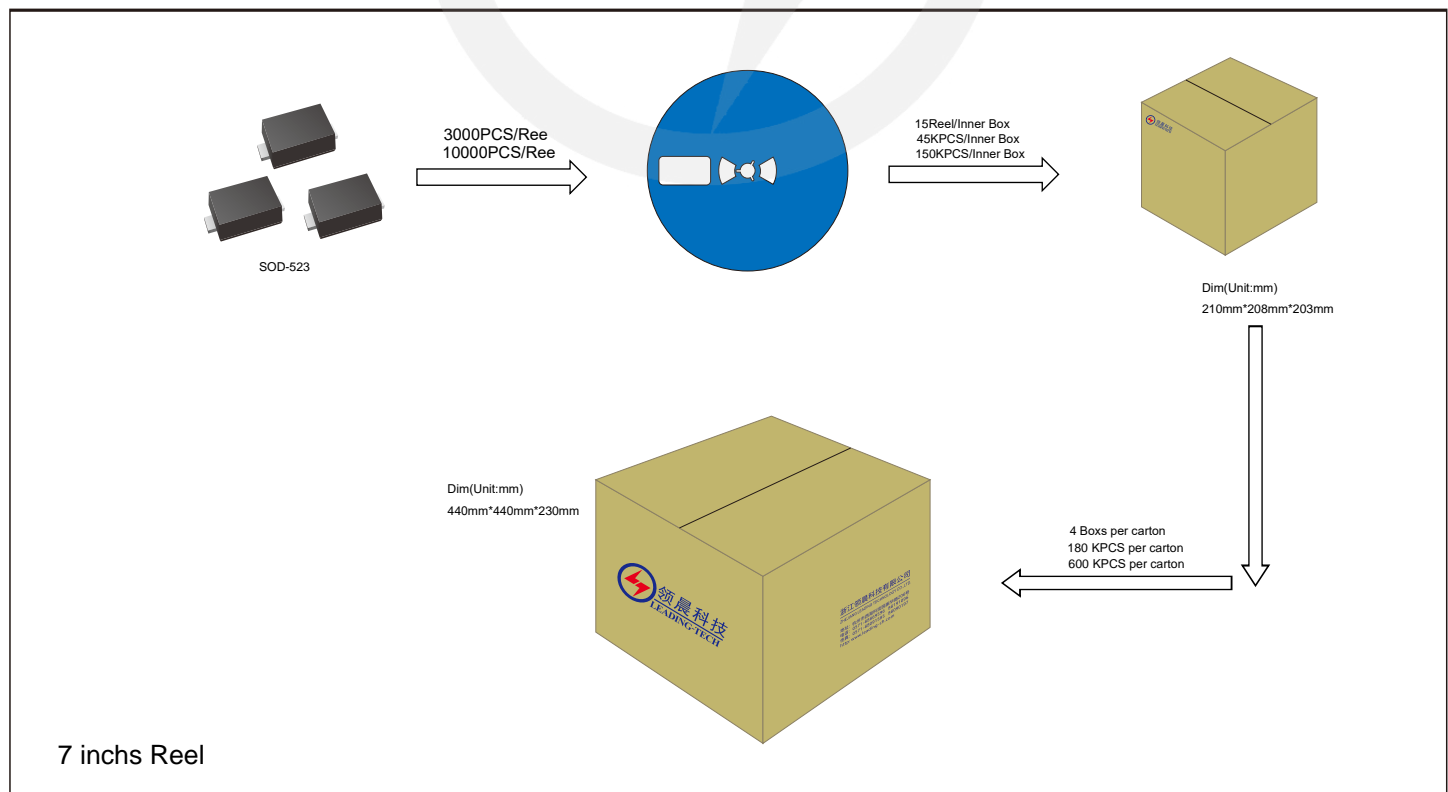



**Recommended Soldering Conditions**

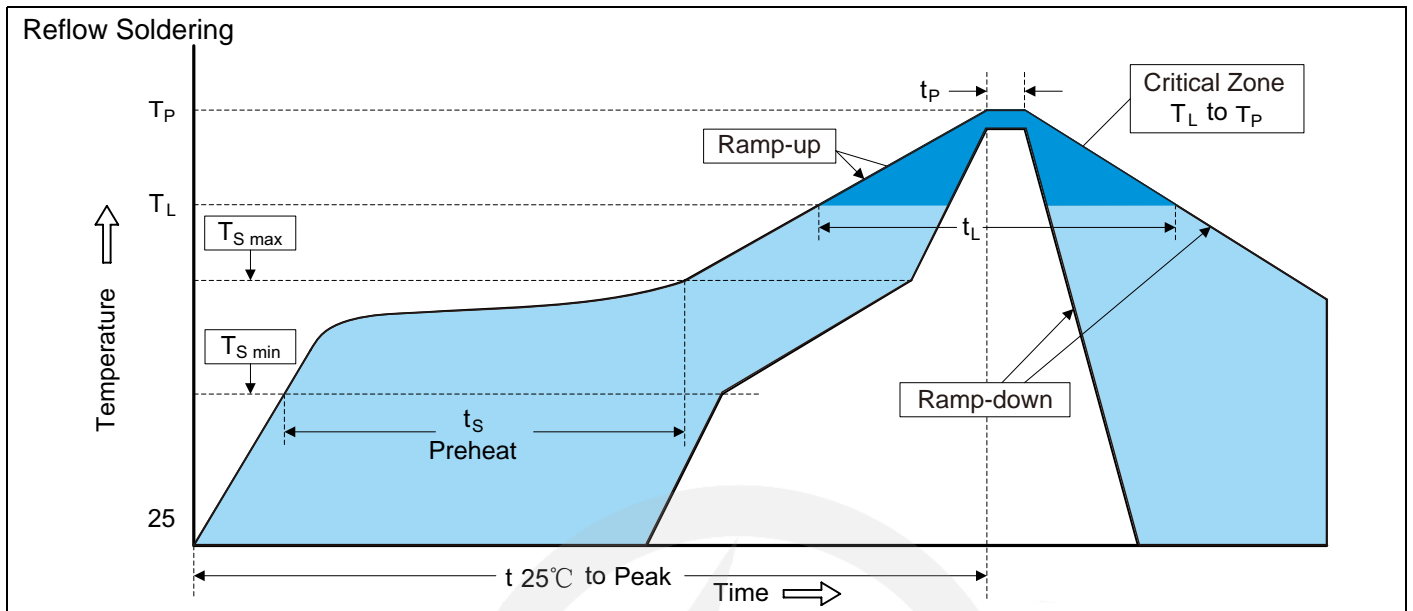

**Recommended Conditions**

Profile Feature	Pb-Free Assembly
Average ramp-up rate ( $T_L$ to $T_P$ )	3°C/second max.
Preheat	
-Temperature Min ( $T_{S\ min}$ )	150°C
-Temperature Max ( $T_{S\ max}$ )	200°C
-Time (min to max) ( $t_s$ )	60-180 seconds
$T_{S\ max}$ to $T_L$	
-Ramp-up Rate	3°C/second max.
Time maintained above:	
-Temperature ( $T_L$ )	217°C
-Time ( $t_L$ )	60-150 seconds
Peak Temperature ( $T_P$ )	260°C
Time within 5°C of actual Peak Temperature ( $t_p$ )	20-40 seconds
Ramp-down Rate	6°C/second max.
Time 25°C to Peak Temperature	8 minutes max.

## Important Notice and Disclaimer

Leading-Tech reserves the right to make changes to this document and its products and specifications at any time without notice.

Customers should obtain and confirm the latest product information and specifications before final design, purchase or use.

Leading-Tech makes no warranty, representation or guarantee regarding the suitability of its products for any particular purpose, not does Leading-Tech assume any liability for application assistance or customer product design.

Leading-tech does not warrant or accept any liability with products which are purchase or used for any unintended or unauthorized application.

No license is granted by implication or otherwise under any intellectual property rights of Leading-Tech.

Leading-Tech products are not authorized for use as critical components in life support devices or systems without express written approval of Leading-tech.

## Version Update Information

Series NO.	Enactment/Revision Date	Effective Date	Version	Revision content	Revision Reason	Revision Person	Note
01	2024.10.2	2024.10.2	3.0	New File	/	Ding	