

Ultra Low Capacitance ESD Protection Diode

Features

- Transient protection for high-speed data lines
IEC 61000-4-2(ESD) $\pm 20\text{KV}$ (Contact)
 $\pm 25\text{KV}$ (Air)
IEC 61000-4-4(EFT)40A(5/50ns)
Cable Discharge Event(CDE)
- Package optimized for high-speed lines
- Small package(2.9mm*2.8mm*1.1mm)
- Protects four data lines and one Vcc line
- Low capacitance: 0.20pF (I/O to I/O)
- Low leakage current
- Low clamping voltage
- Each I/O pin can withstand over 1000 ESD strikes
for $\pm 8\text{KV}$ contact discharge
- Lead free in comply with EU RoHS 2011/65/EU directives

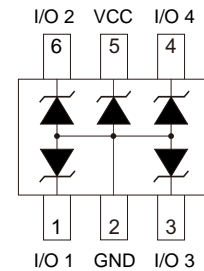
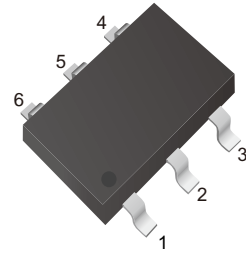

Mechanical Datas

- Case:SOT-26
- Flammability Rating: UL 94V-0
- Terminal: Matte tin plated
- Material:Halogen free

Applications

- Serial ATA
- MDDI Ports
- USB 2.0/3.0 Power and Data Line Protection
- Display Ports
- High Definition Multi-Media Interface (HDMI)
- Digital Visual Interface (DVI)

Ordering Information

Part Number	Marking	Shipping	Reel
LTE26T05A04T-TR3	V05	3000PCS Tape&Reel	7 inches
LTE26T05A04T-TR10	V05	10000PCS Tape&Reel	13 inches

Absolute Maximum Ratings

Symbol	Parameter	Value	Unit
P_{PP}	Peak Pulse Power (8/20 μ s)	60	W
V_{ESD}	ESD per IEC 61000-4-2 (Air) ESD per IEC 61000-4-2 (Contact)	± 25 ± 20	kV
T_{OPT}	Operating Temperature	-55/+125	$^{\circ}\text{C}$
T_{STG}	Storage Temperature	-55/+150	$^{\circ}\text{C}$

Electrical Characteristics ($T_a=25^\circ\text{C}$)

Symbol	Parameter	Test Condition	Min	Typ	Max	Unit
V_{RWM}	Reverse Working Voltage	Any I/O pin to GND			5.0	V
V_{BR}	Reverse Breakdown Voltage	$I_T = 1\text{mA}$ Any I/O pin to GND	6.0		9.0	V
I_R	Reverse Leakage Current	$V_{RWM} = 5\text{V}$ Any I/O pin to GND			1.0	μA
V_C	Clamping Voltage	$I_{PP} = 1\text{A}, t_p = 8/20\mu\text{s}$ Any I/O pin to GND			10	V
		$I_{PP} = 4\text{A}, t_p = 8/20\mu\text{s}$ Any I/O pin to GND			15	V
		$I_{PP} = 8\text{A}, t_p = 8/20\mu\text{s}$ Vcc pin to GND			15	V
C_{ESD}	Parasitic Capacitance	$V_R = 0\text{V}, f = 1\text{MHz}$ Between I/O and I/O		0.20	0.50	pF
		$V_R = 0\text{V}, f = 1\text{MHz}$ Between I/O and GND		0.45	0.80	pF
		$V_R = 0\text{V}, f = 1\text{MHz}$ Between Vcc and GND		0.80		pF

Note: I/O Pins are pin 1,3,4,6. Pin 5 is Vcc. Pin 2 is GND.

Electrical Characteristics Curve

Insertion Loss S21 of I/O to GND

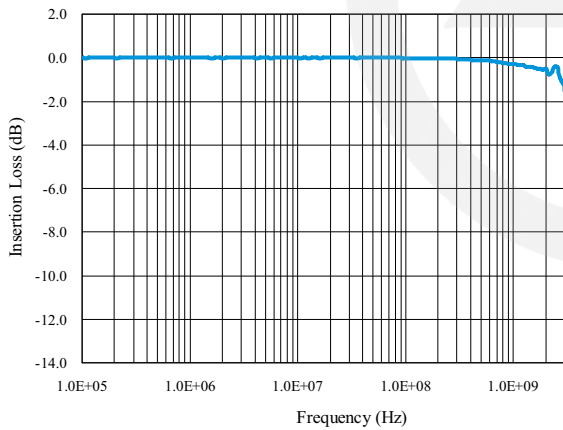

Normalized Capacitance vs. Reverse Voltage

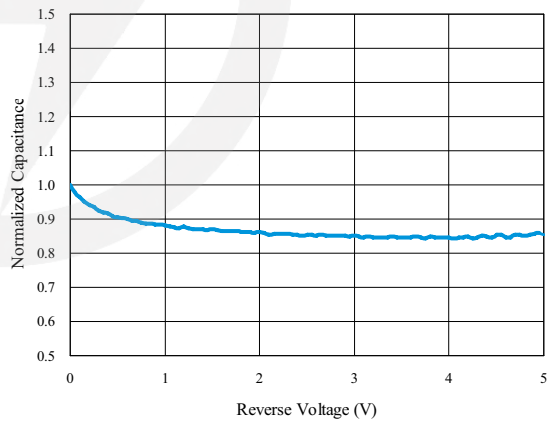
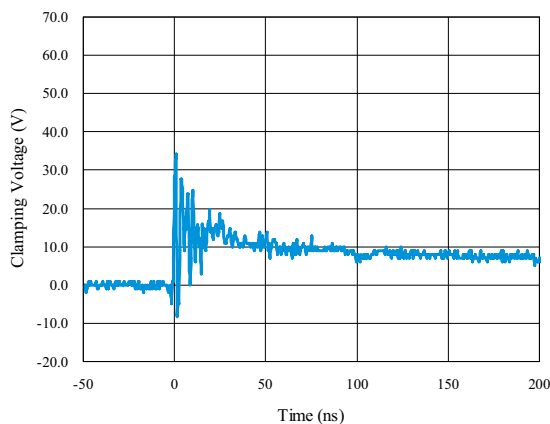
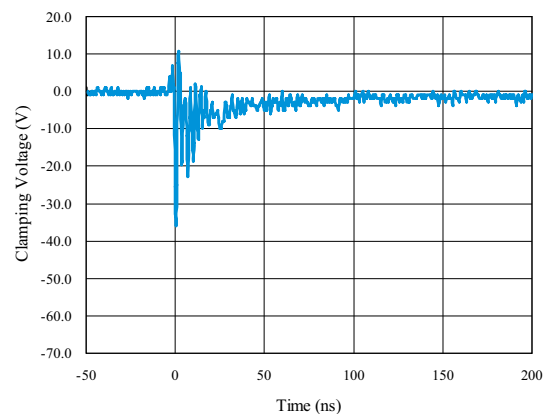
 ESD Clamping
 (+8kV Contact per IEC 61000-4-2)

 ESD Clamping
 (-8kV Contact per IEC 61000-4-2)

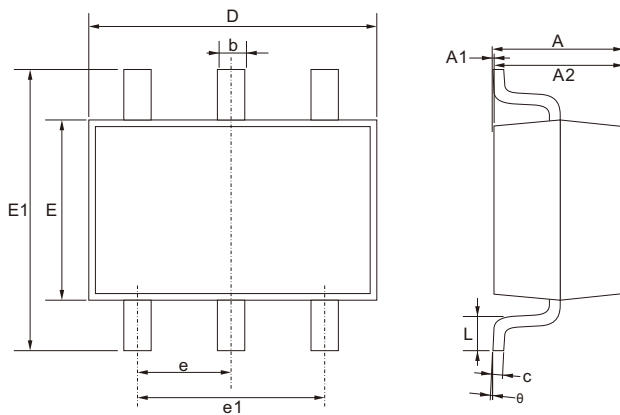

SOT-26 Package Outline

Unit: mm



SYMBOL	DIMENSIONS	
	MIN.	MAX.
A	1.050	1.250
A1	0.000	0.100
A2	1.050	1.150
b	0.300	0.500
c	0.100	0.200
D	2.820	3.020
E	1.500	1.700
E1	2.650	2.950
e	0.950 TYP.	
e1	1.800	2.000
L	0.300	0.600
θ	0°	8°

SOT-26 Suggested Pad Layout

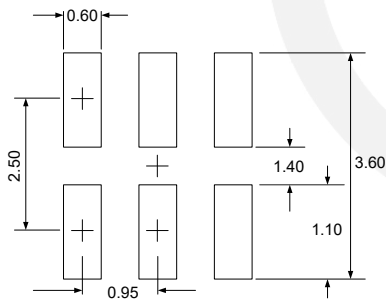

Note:

1. Controlling dimension: in millimeters.
2. General tolerance: $\pm 0.05\text{mm}$
3. The pad layout is for reference purpose only.

Reel Dimensions

Unit : mm

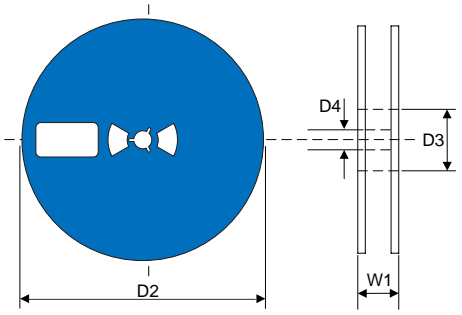
<p>7" Reel</p> 	D2	$\Phi 178.0 \pm 2.0$
	D3	$\Phi 50$
	D4	13.0 ± 0.5
	W1	12 ± 0.5
	Quantity: 3000PCS	

Reel Dimensions

Unit : mm

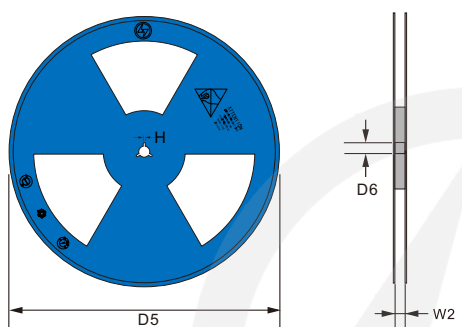
<p>13" Reel</p> 	D5	$\Phi 330.0 \pm 2.0$
	D6	$\Phi 13.5 \pm 0.5$
	H	2.5 ± 1.0
	W2	12 ± 0.5
	Quantity: 10000PCS	

Packaging

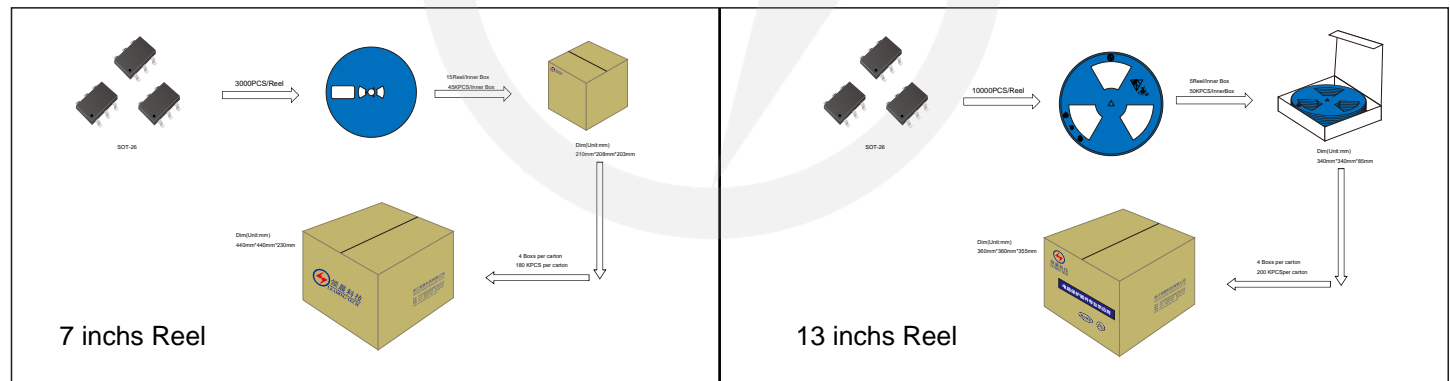



Recommended Soldering Conditions



Recommended Conditions

Profile Feature	Pb-Free Assembly
Average ramp-up rate (T _L to T _P)	3°C/second max.
Preheat	
-Temperature Min (T _{S min})	150°C
-Temperature Max (T _{S max})	200°C
-Time (min to max) (t _s)	60-180 seconds
T _{S max} to T _L	
-Ramp-up Rate	3°C/second max.
Time maintained above:	
-Temperature (T _L)	217°C
-Time (t _L)	60-150 seconds
Peak Temperature (T _P)	260°C
Time within 5°C of actual Peak Temperature (t _p)	20-40 seconds
Ramp-down Rate	6°C/second max.
Time 25°C to Peak Temperature	8 minutes max.

Important Notice and Disclaimer

Leading-Tech reserves the right to make changes to this document and its products and specifications at any time without notice.

Customers should obtain and confirm the latest product information and specifications before final design, purchase or use.

Leading-Tech makes no warranty, representation or guarantee regarding the suitability of its products for any particular purpose, not does Leading-Tech assume any liability for application assistance or customer product design.

Leading-tech does not warrant or accept any liability with products which are purchase or used for any unintended or unauthorized application.

No license is granted by implication or otherwise under any intellectual property rights of Leading-Tech.

Leading-Tech products are not authorized for use as critical components in life support devices or systems without express written approval of Leading-tech.

Version Update Information

Series NO.	Enactment/Revision Date	Effective Date	Version	Revision content	Revision Reason	Revision Person	Note
01	2024.05.16	2024.05.16	3.0	New File	/	Ding	
02	2025.06.17	2025.06.17	3.1	Update packaging information	/	Ding	