

TVS Diode Array

Features

- IEC61000-4-2 (ESD) $\pm 30\text{kV}$ (air), $\pm 30\text{kV}$ (contact)
- IEC61000-4-4 (EFT) 40A (5/50ns)
- 350 Watts Peak Pulse Power per (tp=8/20 μs)
- Protects one bidirectional line or two
- Low clamping voltage unidirectional lines
- Working voltages : 3.3V~36V
- Low leakage current
- Lead free in comply with EU RoHS 2011/65/EU directives
- Moisture Sensitivity Level1

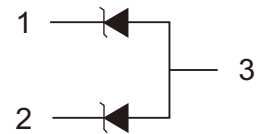
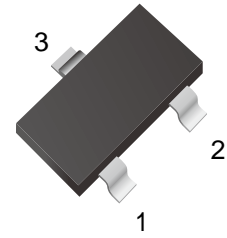

Mechanical Data

- Case: SOT-23
- Flammability Rating: UL 94V-0

Applications

- Cell Phone Handsets and Accessories
- Microprocessor based equipment
- Personal Digital Assistants (PDA's)
- Notebooks, Desktops, and Servers
- Portable Instrumentation
- Networking and Telecom
- Serial and Parallel Ports.
- Peripherals

Ordering Information

Part Number	Shipping	Reel
LTE23TxxA02G-TR3	3000PCS Tape&Reel	7 inchs
LTE23TxxA02G-TR12	12000PCS Tape&Reel	13 inchs

Absolute Maximum Ratings

Symbol	Parameter	Value	Unit
V _{ESD}	ESD per IEC 61000-4-2 (Air)	±30	kV
	ESD per IEC 61000-4-2 (Contact)	±30	
P _{PP}	Peak Pulse Power (8/20μs)	350	W
T _{OPT}	Operating Temperature	-55/+150	°C
T _{STG}	Storage Temperature	-55/+150	°C
T _L	Lead Soldering Temperature	260 (10 sec.)	°C

Electrical Characteristics (TA=25°C unless otherwise specified)

Part Number	Marking	V _{RWM}	V _B	I _r	V _{C@1A}	V _C		I _R	C _J
		(V) (max.)	(V) (min.)	(mA)	(V) (max.)	(V) (max.)	(@A)	(μA) (max.)	(pF) (max.)
LTE23T03A02G	M03	3.3	4	1	7.0	14	20	40	450
LTE23T05A02G	M05	5	6	1	9.8	18	17	10	300
LTE23T08A02G	M08	8	8.5	1	13.4	24	15	2	240
LTE23T12A02G	M12	12	13.3	1	19	32	11	1	130
LTE23T15A02G	M15	15	16.7	1	24	38	10	1	120
LTE23T18A02G	M18	18	20	1	29	45	9	1	100
LTE23T20A02G	M20	20	22.3	1	35	50	8	1	90
LTE23T24A02G	M24	24	26.7	1	43	52	7	1	80
LTE23T36A02G	M36	36	40	1	60	75	5	1	60



Characteristics Curves

Fig.1 8x20μs Waveform per IEC61000-4-5

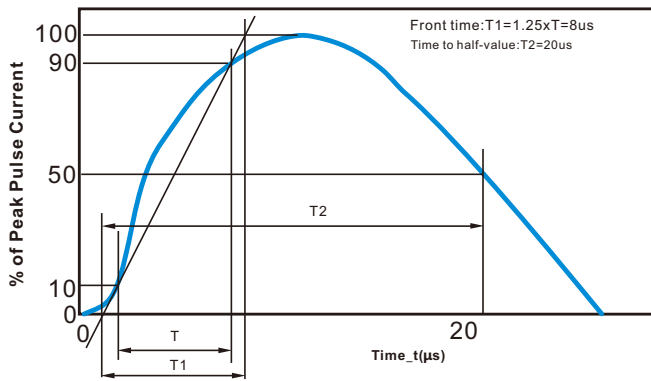

Fig.2 Contact Discharge Current Waveform per IEC 61000-4-2

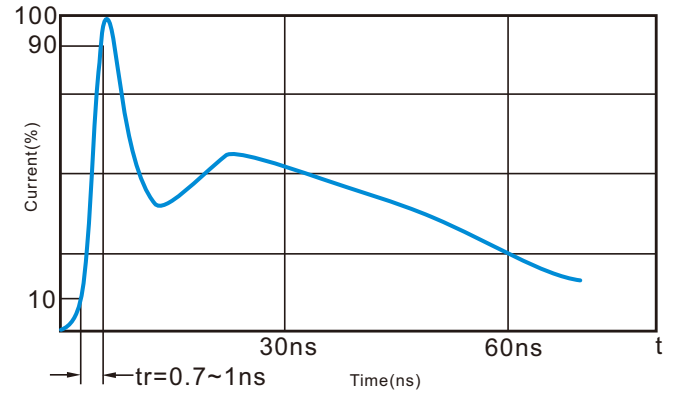

Fig.3 Voltage vs Capacitance

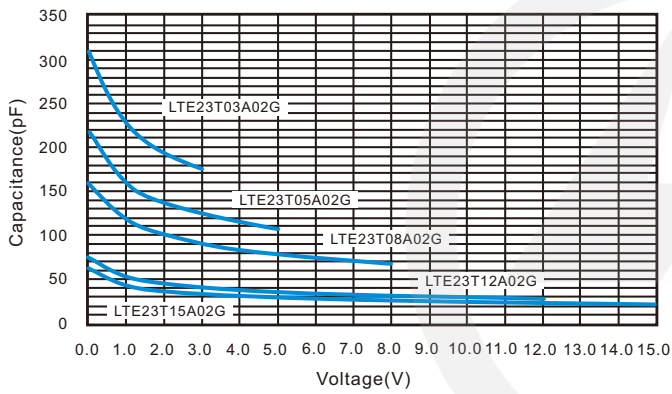

Fig.4 Voltage vs Capacitance

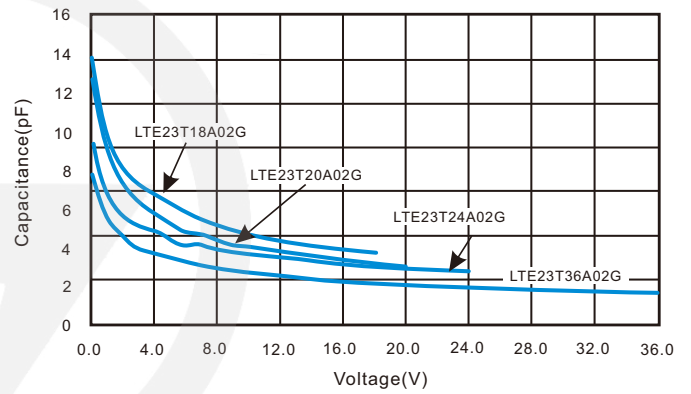

Fig.5 Clamping Voltage vs. Peak Pulse Current($t_p=8/20\mu s$)

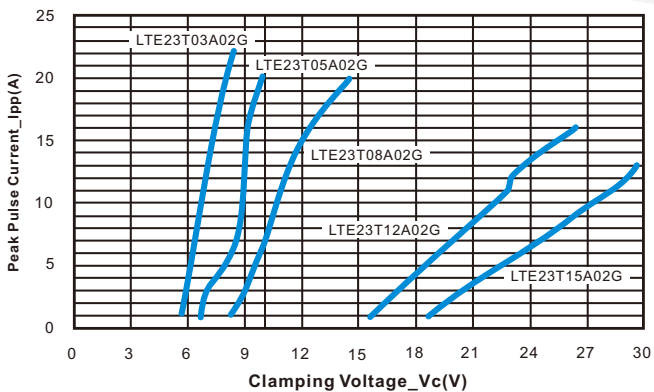
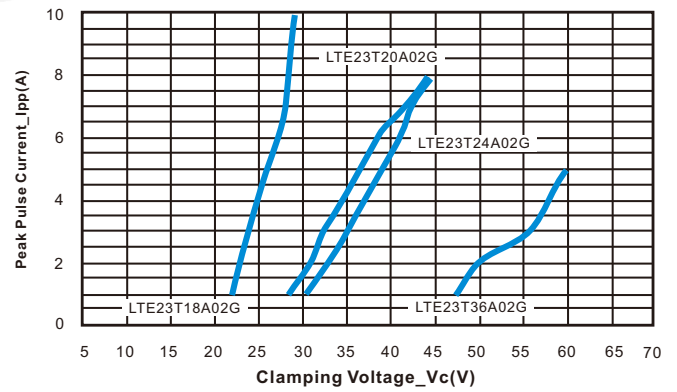
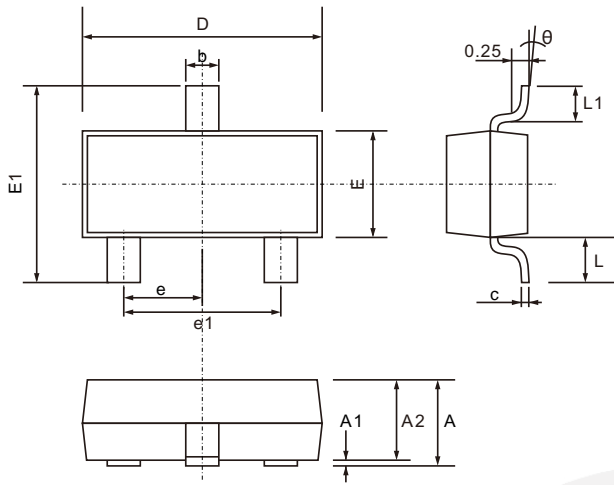

Fig.5 Clamping Voltage vs. Peak Pulse Current($t_p=8/20\mu s$)



SOT-23 Package Outline

Unit: mm



SYMBOL	DIMENSIONS	
	MIN.	MAX.
A	0.900	1.200
A1	0.000	0.100
A2	0.900	1.050
b	0.300	0.500
c	0.080	0.200
D	2.700	3.100
E	1.200	1.400
E1	2.200	2.600
e	0.950 TYP.	
e1	1.750	2.050
L	0.550 TYP.	
L1	0.300	0.500
θ	0°	8°

SOT-23 Suggested Pad Layout

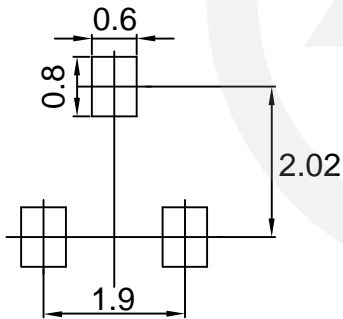

Note:
 1. Controlling dimension: in millimeters.
 2. General tolerance: $\pm 0.05\text{mm}$
 3. The pad layout is for reference purpose only.

Carrier Tape Dimensions

Unit : mm

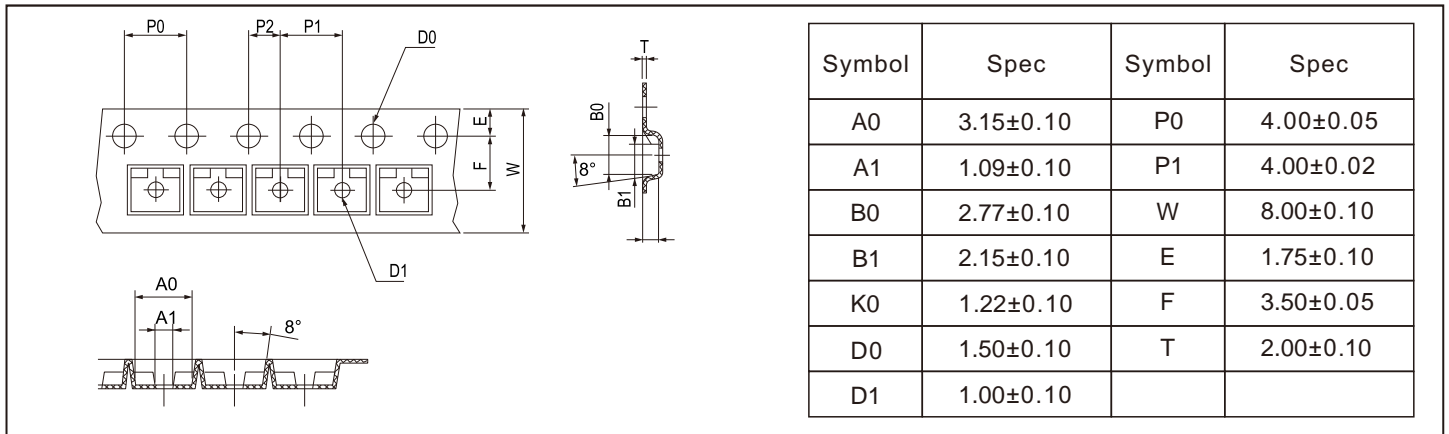

Reel Dimensions

Unit : mm

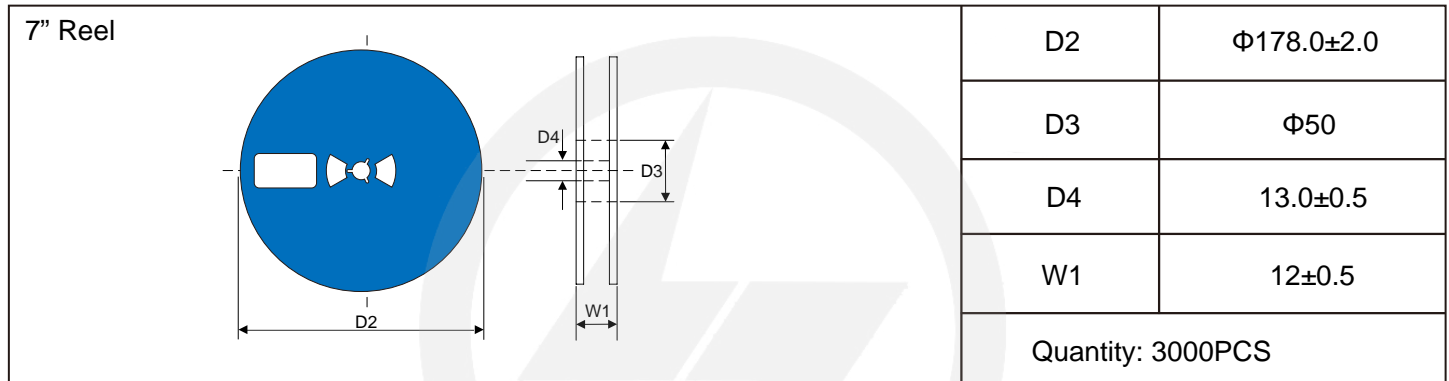

Reel Dimensions

Unit : mm

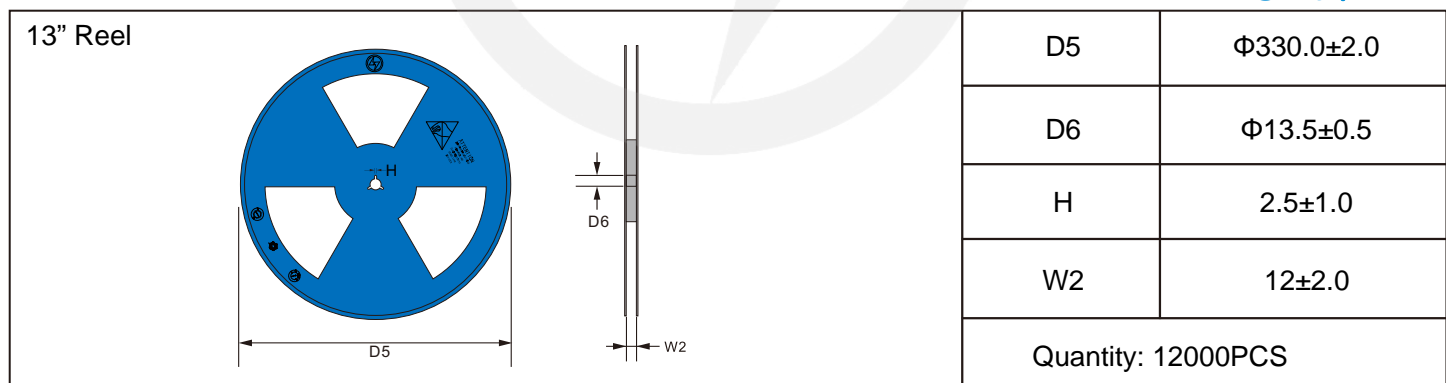

Packaging

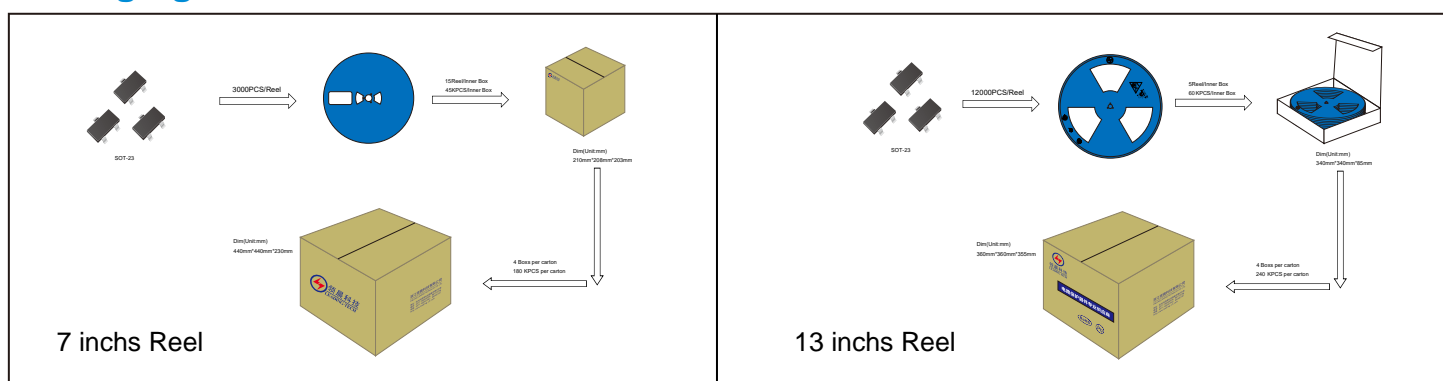



Recommended Soldering Conditions



Recommended Conditions

Profile Feature	Pb-Free Assembly
Average ramp-up rate (T_L to T_P)	3°C/second max.
Preheat	
-Temperature Min ($T_{S\ min}$)	150°C
-Temperature Max ($T_{S\ max}$)	200°C
-Time (min to max) (t_s)	60-180 seconds
$T_{S\ max}$ to T_L	
-Ramp-up Rate	3°C/second max.
Time maintained above:	
-Temperature (T_L)	217°C
-Time (t_L)	60-150 seconds
Peak Temperature (T_P)	260°C
Time within 5°C of actual Peak Temperature (t_p)	20-40 seconds
Ramp-down Rate	6°C/second max.
Time 25°C to Peak Temperature	8 minutes max.

Important Notice and Disclaimer

Leading-Tech reserves the right to make changes to this document and its products and specifications at any time without notice.

Customers should obtain and confirm the latest product information and specifications before final design, purchase or use.

Leading-Tech makes no warranty, representation or guarantee regarding the suitability of its products for any particular purpose, not does Leading-Tech assume any liability for application assistance or customer product design.

Leading-Tech does not warrant or accept any liability with products which are purchase or used for any unintended or unauthorized application.

No license is granted by implication or otherwise under any intellectual property rights of Leading-Tech.

Leading-Tech products are not authorized for use as critical components in life support devices or systems without express written approval of Leading-Tech.

Version Update Information

Series NO.	Enactment/Revision Date	Effective Date	Version	Revision Content	Revision Reason	Revision Person	Note
01	2024.03.18	2024.03.18	3.0	New file	/	Ding	
02	2025.06.11	2025.06.11	3.1	Update packaging information	/	Ding	
03	2026.03.04	2026.03.04	3.2	Package outline E1(max)=2.6mm	/	Ding	