

## Surface Mount Superfast Recovery Rectifier

### Features

- Easy pick and place
- For surface mounted applications
- Low profile package
- Built-in strain relief
- Superfast recovery times for high efficiency
- Lead free in comply with EU RoHS 2011/65/EU directives



### Mechanical Data

- Case: SOD-123FL
- Terminals: Solderable per MIL-STD-750, Method 2026

### Ordering Information

Part Number	Shipping	Reel
LTE1AL THRU LTE1JL-TR3	3000PCS Tape&Reel	7 inches
LTE1AL THRU LTE1JL-TR12	12000PCS Tape&Reel	13 inches

### Absolute Maximum Ratings and Characteristics

Ratings at 25 °C ambient temperature unless otherwise specified. Single phase, half wave, 60 Hz, resistive or inductive load. For capacitive load, derate current by 20%

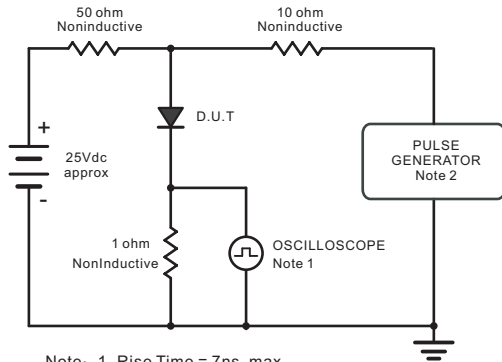
Parameter	Symbol	LTE1AL	LTE1BL	LTE1CL	LTE1DL	LTE1EL	LTE1GL	LTE1JL	Unit
Maximum Repetitive Peak Reverse Voltage	$V_{RRM}$	50	100	150	200	300	400	600	V
Maximum RMS voltage	$V_{RMS}$	35	70	105	140	210	280	420	V
Maximum DC Blocking Voltage	$V_{DC}$	50	100	150	200	300	400	600	V
Maximum Average Forward Rectified Current at $T_c = 125\text{ }^\circ\text{C}$	$I_{F(AV)}$	1							A
Peak Forward Surge Current 8.3 ms Single Half Sine Wave Superimposed on Rated Load	$I_{FSM}$	30							A
Maximum Forward Voltage at 1 A	$V_F$	1				1.25		1.68	V
Maximum DC Reverse Current $T_a = 25\text{ }^\circ\text{C}$ at Rated DC Blocking Voltage $T_a = 125\text{ }^\circ\text{C}$	$I_R$	5 100							$\mu\text{A}$
Typical Junction Capacitance at $V_R=4\text{V}$ , $f=1\text{MHz}$	$C_j$	15							pF
Maximum Reverse Recovery Time (Note1)	$t_{rr}$	35							ns
Typical Thermal Resistance (Note2)	$R_{\theta JA}$	85							$^\circ\text{C/W}$
Operating and Storage Temperature Range	$T_j, T_{stg}$	-55 ~ +150							$^\circ\text{C}$

Note: ( 1 ) Measured with  $I_F = 0.5\text{ A}$ ,  $I_R = 1\text{ A}$ ,  $I_{rr} = 0.25\text{ A}$ .

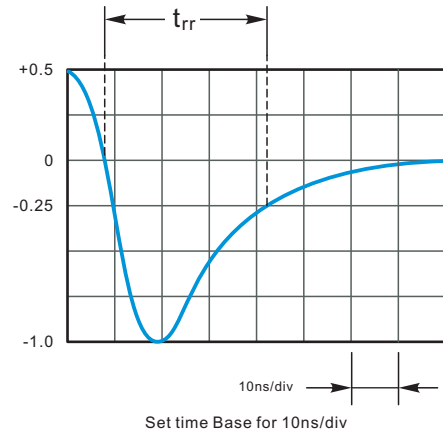
( 2 ) P.C.B. mounted with 2.0" X 2.0" (5cm X 5cm) copper pad areas.

## Characteristics Curve

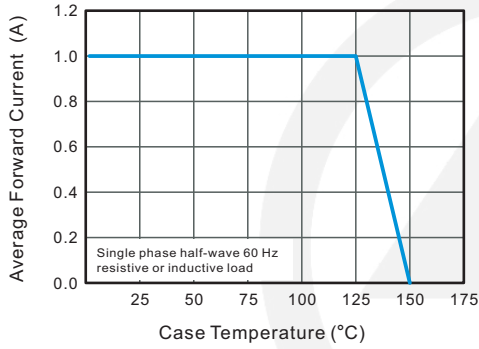
**Fig.1 Reverse Recovery Time Characteristic And Test Circuit Diagram**



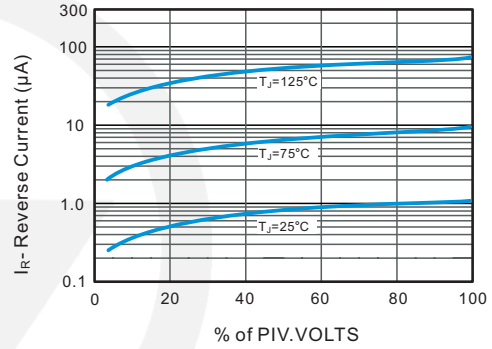
Note: 1. Rise Time = 7 ns, max.  
Input Impedance = 1 megohm, 22pF.  
2. Rise Time = 10 ns, max.  
Source Impedance = 50 ohms.



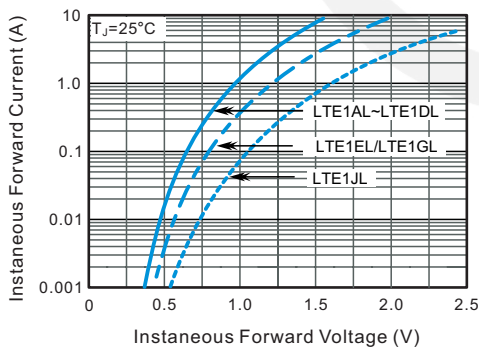
**Fig.2 Maximum Average Forward Current Rating**



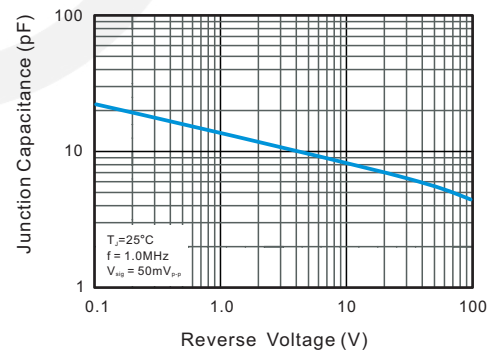
**Fig.3 Typical Reverse Characteristics**



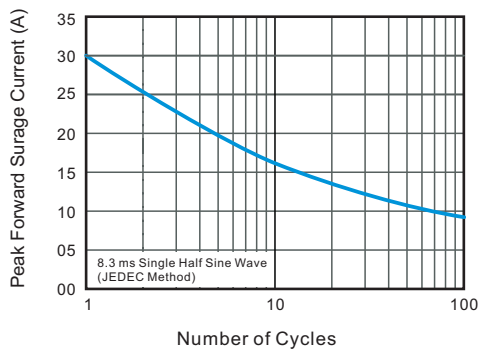
**Fig.4 Typical Forward Characteristics**



**Fig.5 Typical Junction Capacitance**

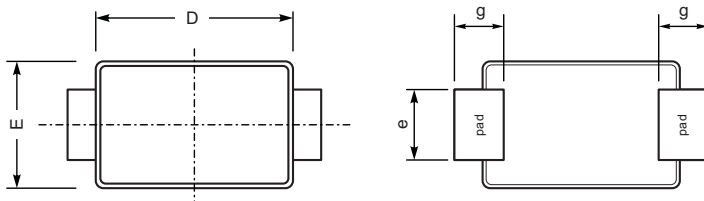
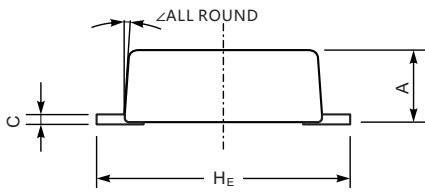


**Fig.6 Maximum Non-Repetitive Peak Forward Surge Current**



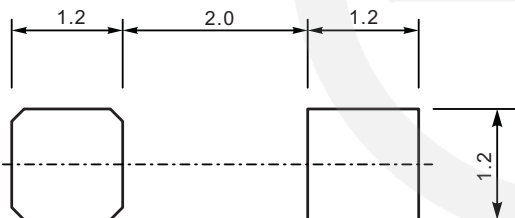
## SOD-123FL Package Outline

Unit: mm



SYMBOL	DIMENSIONS	
	MIN.	MAX.
A	0.9	1.35
C	0.12	0.20
D	2.6	2.9
E	1.75	1.95
e	0.8	1.1
g	0.7	0.9
H <sub>E</sub>	3.5	3.8
∠	7°	

## SOD-123FL Suggested Pad Layout



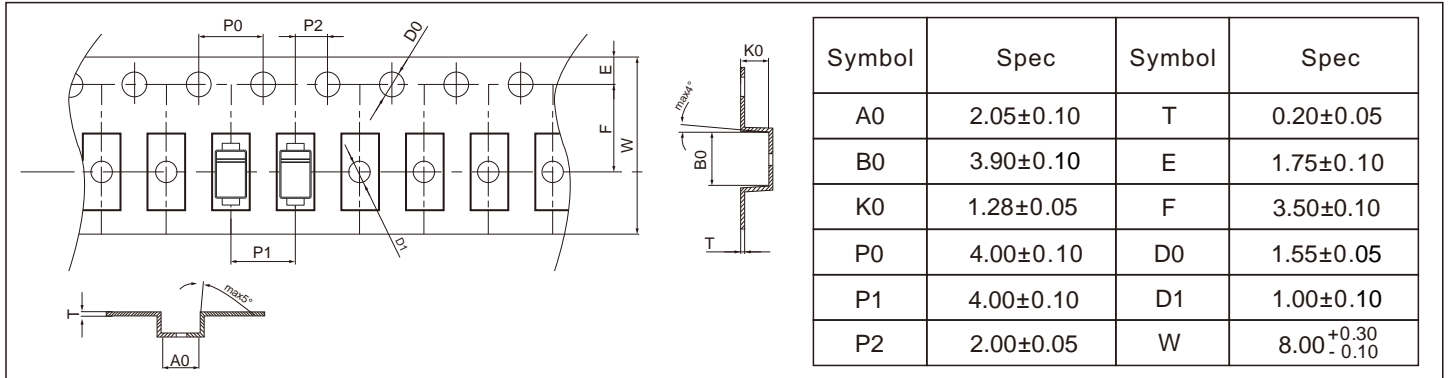
Note:  
 1. Controlling dimension: in millimeters.  
 2. General tolerance:  $\pm 0.05\text{mm}$   
 3. The pad layout is for reference purpose only.

## Marking

Type number	Marking code
LTE1AL	ESL
LTE1BL	ESL
LTE1CL	ESL
LTE1DL	ESL
LTE1EL	ESM
LTE1GL	ESM
LTE1JL	ESH

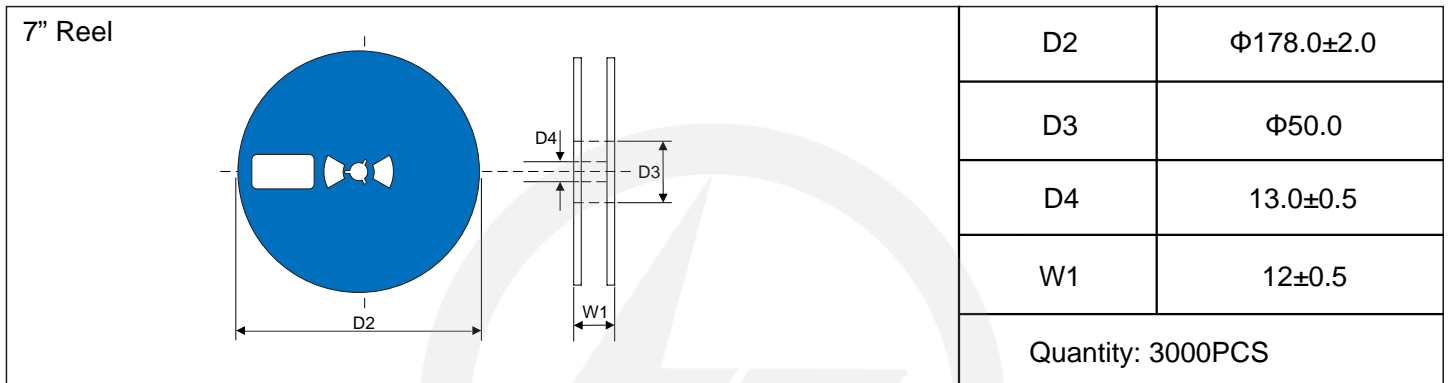
## Carrier Tape Dimensions

Unit : mm



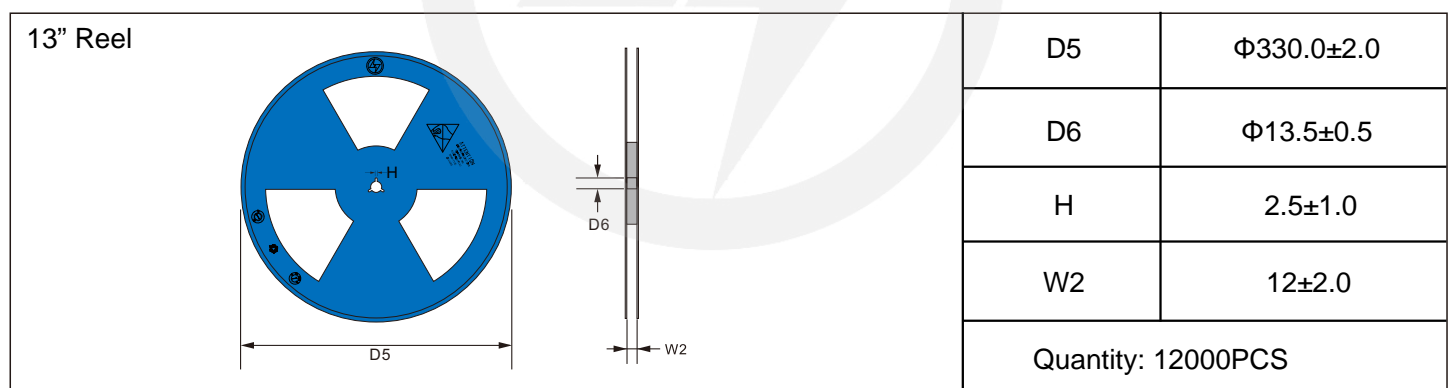
## Reel Dimensions

Unit : mm

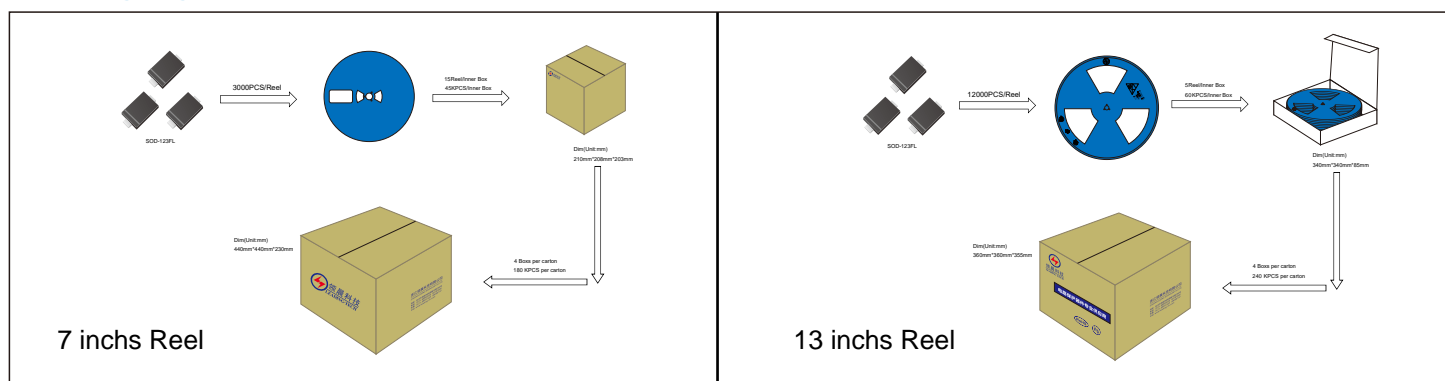


## Reel Dimensions

Unit : mm



## Packaging





Recommended Soldering Conditions



Recommended Conditions

Profile Feature	Pb-Free Assembly
Average ramp-up rate (T <sub>L</sub> to T <sub>P</sub> )	3°C/second max.
Preheat	
-Temperature Min (T <sub>S min</sub> )	150°C
-Temperature Max (T <sub>S max</sub> )	200°C
-Time (min to max) (t <sub>s</sub> )	60-180 seconds
T <sub>S max</sub> to T <sub>L</sub>	
-Ramp-up Rate	3°C/second max.
Time maintained above:	
-Temperature (T <sub>L</sub> )	217°C
-Time (t <sub>L</sub> )	60-150 seconds
Peak Temperature (T <sub>P</sub> )	260°C
Time within 5°C of actual Peak Temperature (t <sub>p</sub> )	20-40 seconds
Ramp-down Rate	6°C/second max.
Time 25°C to Peak Temperature	8 minutes max.

## Important Notice and Disclaimer

Leading-Tech reserves the right to make changes to this document and its products and specifications at any time without notice.

Customers should obtain and confirm the latest product information and specifications before final design, purchase or use.

Leading-Tech makes no warranty, representation or guarantee regarding the suitability of its products for any particular purpose, not does Leading-Tech assume any liability for application assistance or customer product design.

Leading-tech does not warrant or accept any liability with products which are purchase or used for any unintended or unauthorized application.

No license is granted by implication or otherwise under any intellectual property rights of Leading-Tech.

Leading-Tech products are not authorized for use as critical components in life support devices or systems without express written approval of Leading-tech.

## Version Update information

Series NO.	Enactment/Revision Date	Effective Date	Version	Revision content	Revision Reason	Revision Person	Note
01	2024.4.19	2024.4.19	3.0	New File	/	Ding	
02	2025.06.12	2025.06.12	3.1	Update packaging information	/	Ding	