

Features

- IEC 61000-4-2 Level 4 ESD Protection
 - $\pm 30\text{kV}$ Contact Discharge
 - $\pm 30\text{kV}$ Air Discharge
- 120W Peak pulse Power (8/20 μs)
- Low clamping voltage
- Working voltage: 5V
- Low leakage current
- Protecting one Bi-directional lines
- Capacitance: 15pF Typ.
- Lead free in comply with EU RoHS 2011/65/EU directives

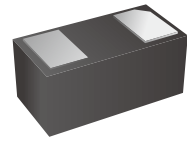

Applications

- MP3 Players
- Battery Protection
- Vbat pin for Mobile Device
- Mobile Phones
- Power Line Protection
- Hand Held portable Applications

Ordering Information

Part Number	Marking	Shipping	Reel
LTE10N05C01D-TR10	PB	10000PCS Tape&Reel	7 inches

Absolute Maximum Rating

Over operating free-air temperature range (unless otherwise noted)

Parameters	Symbol	Min.	Max.	Unit
Peak pulse power (tp=8/20us)	P_{pk}	-	120	W
Peak pulse current (tp=8/20us)	I_{PP}		8	A
ESD (IEC61000-4-2 air discharge)	V_{ESD}	-	± 30	kV
ESD (IEC61000-4-2 contact discharge)	V_{ESD}	-	± 30	kV
Junction temperature	T_J	-	125	$^{\circ}\text{C}$
Operating temperature	T_{OP}	-40	85	$^{\circ}\text{C}$
Storage temperature	T_{STG}	-55	150	$^{\circ}\text{C}$
Lead temperature	T_L	-	260	$^{\circ}\text{C}$



Symbol	Parameters
V_{RWM}	Peak Reverse Working Voltage
I_R	Reverse Leakage Current @ V_{RWM}
V_{BR}	Breakdown Voltage @ I_T
I_T	Test Current
I_{PP}	Maximum Reverse Peak Pulse Current
V_C	Clamping Voltage @ I_{PP}

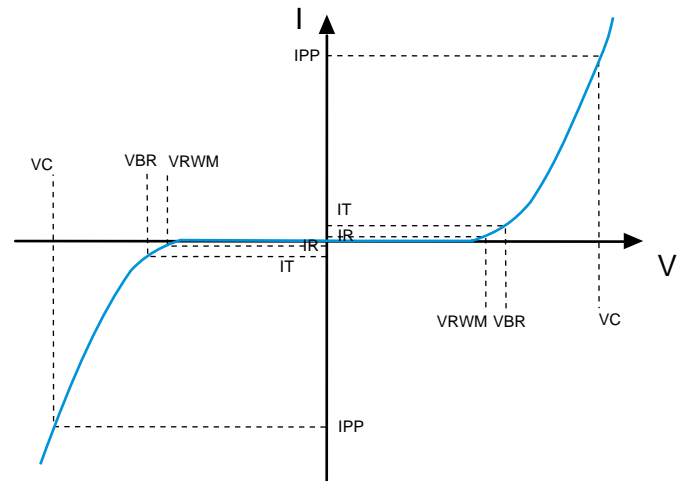

Electrical Characteristics

At $T_A = 25^\circ\text{C}$ unless otherwise noted

Parameter	Symbol	Conditions	Min.	Typ.	Max.	Units
Reverse Stand-off Voltage	V_{RWM}				5	V
Reverse Breakdown Voltage	V_{BR}	$I_T=1\text{mA}$	5.5		7.5	V
Reverse Leakage Current	I_R	$V_{RWM}=5\text{V}$			0.1	μA
Clamping Voltage	V_C	$I_{PP}=1\text{A}; t_p=8/20\mu\text{s}$		6.5	8	V
		$I_{PP}=8\text{A}; t_p=8/20\mu\text{s}$		10	15	V
Junction Capacitance	C_J	$V_R=0\text{V}; f=1\text{MHz}$		15	20	pF



Characteristic Curves

Fig.1 8/20 μ s waveform per IEC61000-4-5

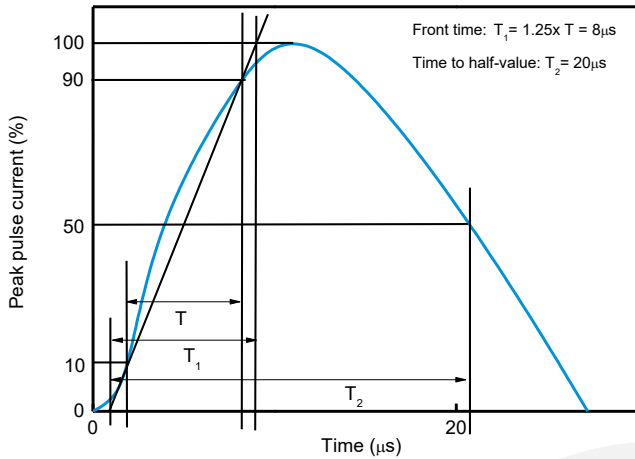

Fig.2 Contact discharge current waveform per IEC61000-4-2

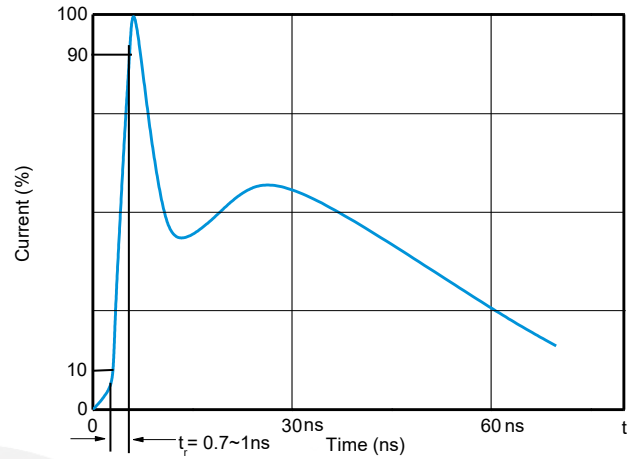

Fig.3 Clamping voltage vs Peak pulse current

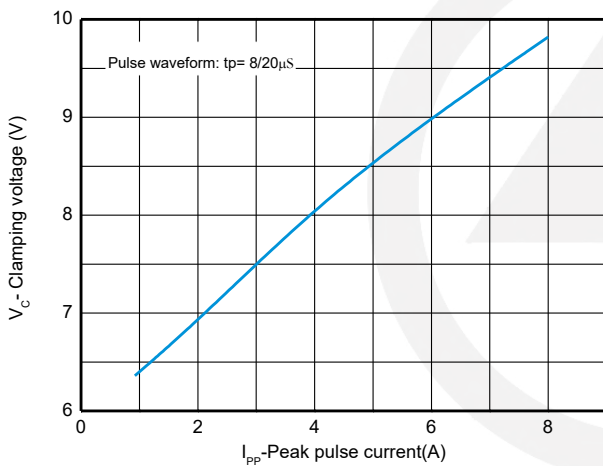

Fig.4 Capacitance vs Reverse voltage

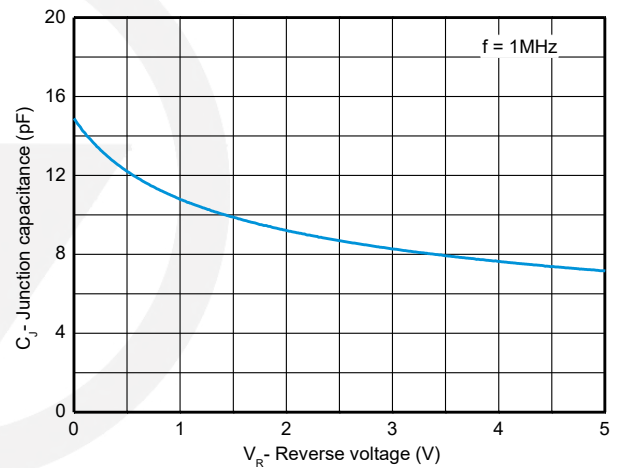

Fig.5 Non-repetitive peak pulse power vs Pulse time

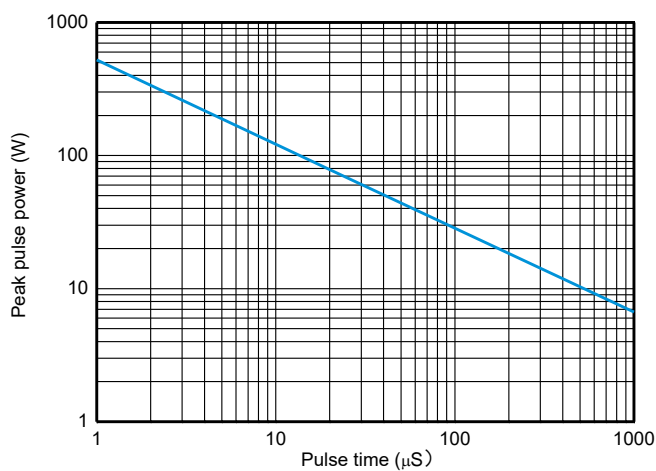
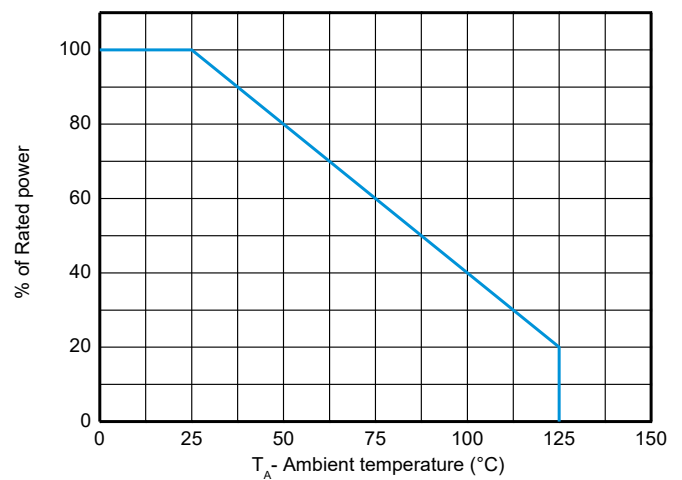
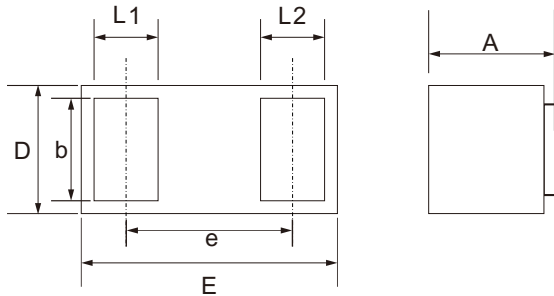

Fig.6 Power derating vs Ambient temperature



DFN1006 Package Outline

Unit: mm



SYMBOL	DIMENSIONS	
	MIN.	MAX.
D	0.550	0.650
E	0.950	1.050
L1	0.200	0.300
L2	0.200	0.300
b	0.450	0.550
e	0.650 TYP.	
A	0.450	0.550

DFN1006 Suggested Pad Layout

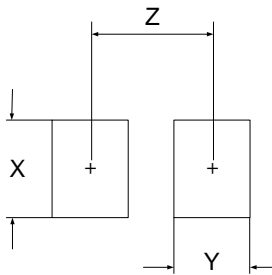

SYM	DIMENSIONS
	MILLIMETERS
X	0.50
Y	0.50
Z	0.90

Note:
 1. Controlling dimension: in millimeters.
 2. General tolerance: $\pm 0.05\text{mm}$
 3. The pad layout is for reference purpose only.

Carrier Tape Dimensions

Unit : mm

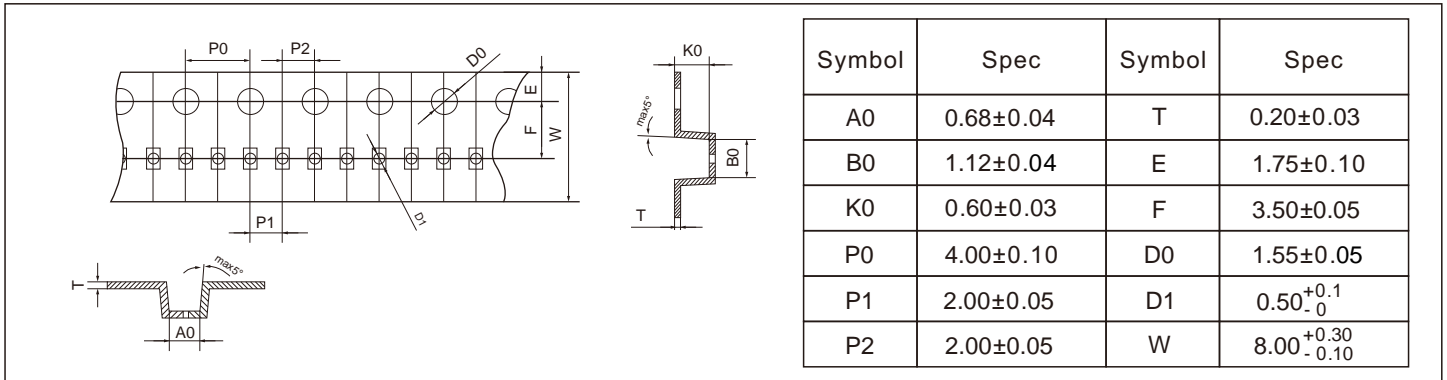

Reel Dimensions

Unit : mm

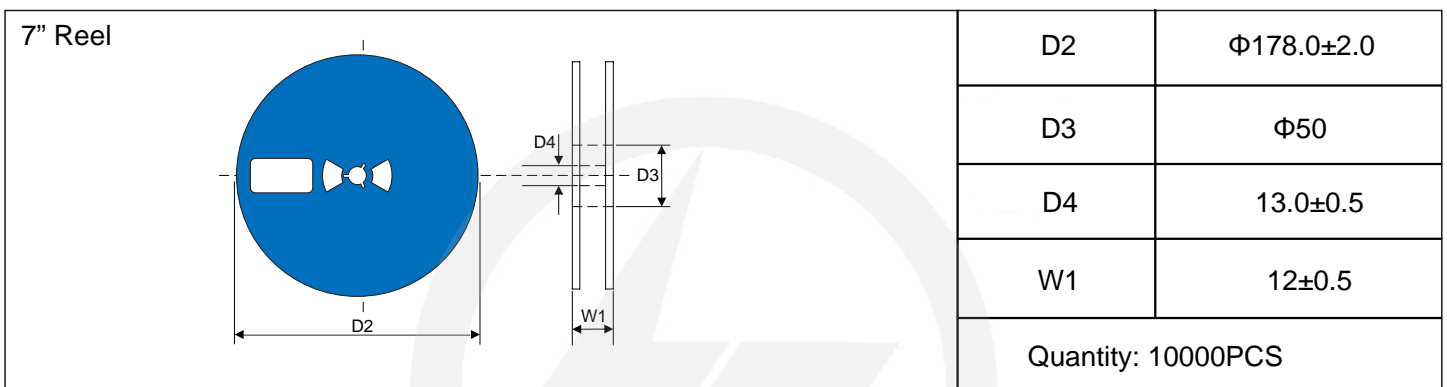

Packaging

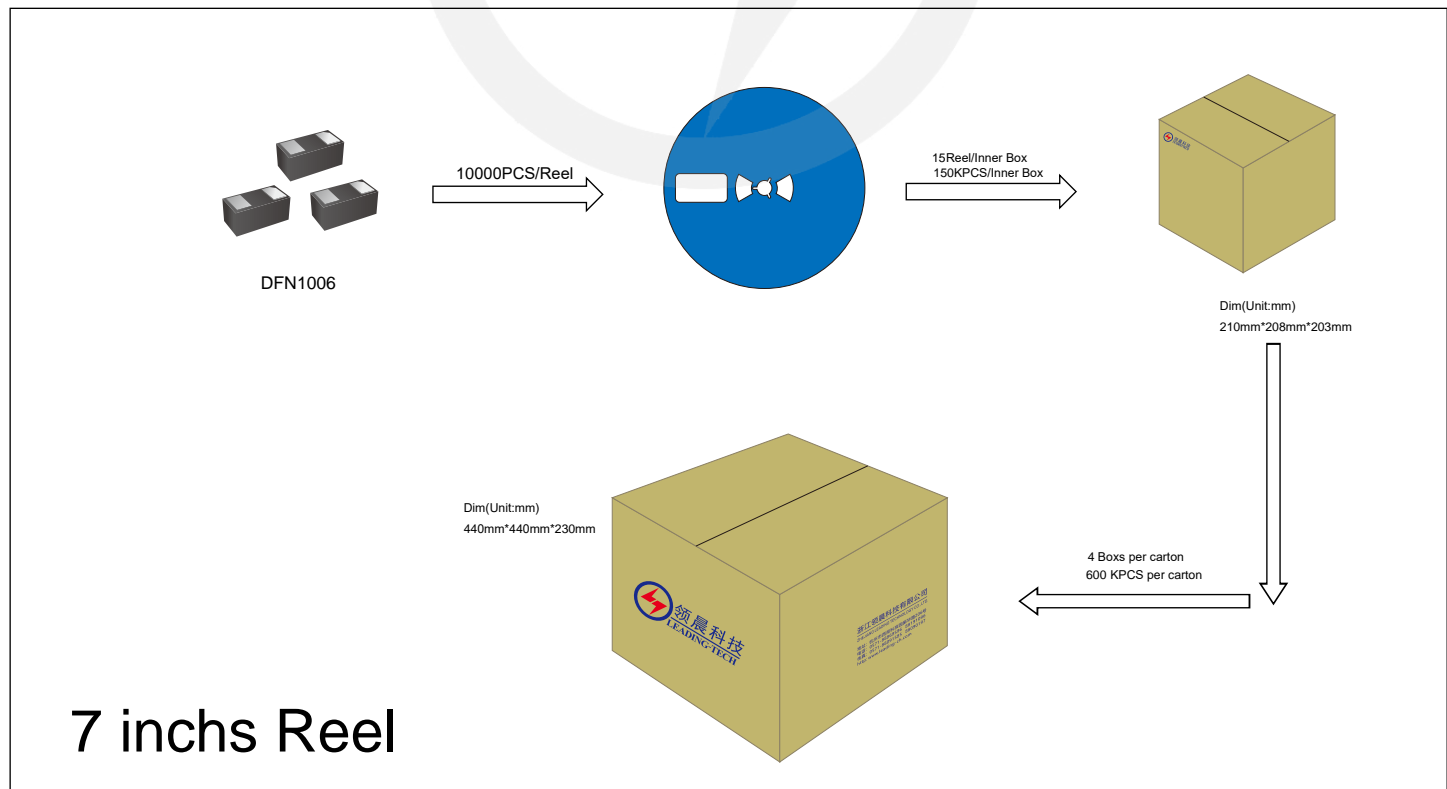



Recommended Soldering Conditions



Recommended Conditions

Profile Feature	Pb-Free Assembly
Average ramp-up rate (T _L to T _P)	3°C/second max.
Preheat	
-Temperature Min (T _{S min})	150°C
-Temperature Max (T _{S max})	200°C
-Time (min to max) (t _s)	60-180 seconds
T _{S max} to T _L	
-Ramp-up Rate	3°C/second max.
Time maintained above:	
-Temperature (T _L)	217°C
-Time (t _L)	60-150 seconds
Peak Temperature (T _P)	260°C
Time within 5°C of actual Peak Temperature (t _p)	20-40 seconds
Ramp-down Rate	6°C/second max.
Time 25°C to Peak Temperature	8 minutes max.

Important Notice and Disclaimer

Leading-Tech reserves the right to make changes to this document and its products and specifications at any time without notice.

Customers should obtain and confirm the latest product information and specifications before final design, purchase or use.

Leading-Tech makes no warranty, representation or guarantee regarding the suitability of its products for any particular purpose, not does Leading-Tech assume any liability for application assistance or customer product design.

Leading-Tech does not warrant or accept any liability with products which are purchase or used for any unintended or unauthorized application.

No license is granted by implication or otherwise under any intellectual property rights of Leading-Tech.

Leading-Tech products are not authorized for use as critical components in life support devices or systems without express written approval of Leading-tech.

Version Update Information

Series NO.	Enactment/Revision Date	Effective Date	Version	Revision content	Revision Reason	Revision Person	Note
01	2025.02.22	2025.02.22	3.0	New File	/	Ding	