

## Dual Transistor (PNP+NPN)

### Features

- Epitaxial Planar DieConstruction
- Ideal for Low Power Amplification and Switching
- One 5551(NPN),One 5401(PNP)
- Lead free in comply with EU RoHS 2011/65/EU directives

### Ordering Information

Part Number	Marking	Shipping	Reel
LTDT5451-TR3	KNM	3000PCS Tape&Reel	7 inches
LTDT5451-TR10	KNM	10000PCS Tape&Reel	13 inches

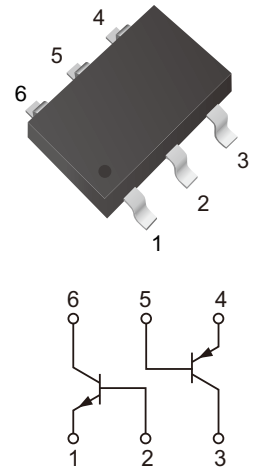

### Maximum Rating NPN5551 (Ta=25 unless otherwise noted)

Symbol	Parameter	Value	Units
$V_{CB0}$	Collector- Base Voltage	180	V
$V_{CEO}$	Collector-Emitter Voltage	160	V
$V_{EBO}$	Emitter-Base Vo	6	V
$I_C$	Collector Current -Continuous	0.2	A
$P_C$	Collector Power Dissipation	0.2	W
$R_{\theta JA}$	Thermal Resistance, Junction to Ambient	625	°C/W
$T_J$	Junction Temperature	150	°C
$T_{stg}$	Storage Temperature	-55-150	°C

### Electrical Characteristics NPN5551 (Ta=25 unless otherwise noted)

Parameter	Symbol	Test conditions	Min	Typ	Max	Unit
Collector-base breakdown voltage	$V_{(BR)CB0}$	$I_C=100\mu A, I_E=0$	180			V
Collector-emitter breakdown voltage	$V_{(BR)CEO}$	$I_C=1mA, I_B=0$	160			V
Emitter-base breakdown voltage	$V_{(BR)EBO}$	$I_E=10\mu A, I_C=0$	6			V
Collector cut-off current	$I_{CB0}$	$V_{CB}=120V, I_E=0$			0.05	$\mu A$
Emitter cut-off current	$I_{EBO}$	$V_{EB}=4V, I_C=0$			0.05	$\mu A$
DC current gain	$h_{FE1}$	$V_{CE}=5V, I_C=1mA$	80			
	$h_{FE2}$	$V_{CE}=5V, I_C=10mA$	100		300	
	$h_{FE3}$	$V_{CE}=5V, I_C=50mA$	30			
Collector-emitter saturation voltage	$V_{CE(sat)}$	$I_C=10mA, I_B=1mA$			0.15	V
		$I_C=50mA, I_B=5mA$			0.2	V
Base-emitter saturation voltage	$V_{BE(sat)}$	$I_C=10mA, I_B=1mA$			1	V
		$I_C=50mA, I_B=5mA$			1	V
Output Capacitance	$C_{obo}$	$V_{CB} = 10V, f = 1.0MHz, I_E = 0$			6.0	pF
Current Gain-Bandwidth Product	$f_T$	$V_{CE} = 10V, I_C = 10mA, f = 100MHz$	100		300	MHz
Noise Figure	NF	$V_{CE}= 5.0V, I_C = 200\mu A, R_S = 1.0k\Omega, f = 1.0kHz$			8.0	dB



Maximum Rating PNP5401 ( Ta=25 unless otherwise noted )

Symbol	Parameter	Value	Units
V <sub>CBO</sub>	Collector- Base Voltage	-160	V
V <sub>CEO</sub>	Collector-Emitter Voltage	-150	V
V <sub>EBO</sub>	Emitter-Base Voltage	-5	V
I <sub>C</sub>	Collector Current -Continuous	-0.2	A
P <sub>C</sub>	Collector Power Dissipation	0.2	W
R <sub>θJA</sub>	Thermal Resistance, Junction to Ambient	625	°C/W
T <sub>J</sub>	Junction Temperature	150	°C
T <sub>stg</sub>	Storage Temperature	-55-150	°C

Electrical Characteristics PNP5401 ( Ta=25 unless otherwise noted )

Parameter	Symbol	Test conditions	Min	Typ	Max	Unit
Collector-base breakdown voltage	V <sub>(BR)CBO</sub>	I <sub>C</sub> =-100μA, I <sub>E</sub> =0	-160			V
Collector-emitter breakdown voltage	V <sub>(BR)CEO</sub>	I <sub>C</sub> =-1mA, I <sub>B</sub> =0	-150			V
Emitter-base breakdown voltage	V <sub>(BR)EBO</sub>	I <sub>E</sub> =-10μA, I <sub>C</sub> =0	-5			V
Collector cut-off current	I <sub>CBO</sub>	V <sub>CB</sub> =-120V, I <sub>E</sub> =0			-50	nA
Emitter cut-off current	I <sub>EBO</sub>	V <sub>EB</sub> =-3V, I <sub>C</sub> =0			-50	nA
DC current gain	h <sub>FE1</sub>	V <sub>CE</sub> =-5V, I <sub>C</sub> =-1mA	50			
	h <sub>FE2</sub>	V <sub>CE</sub> =-5V, I <sub>C</sub> =-10mA	100		300	
	h <sub>FE3</sub>	V <sub>CE</sub> =-5V, I <sub>C</sub> =-50mA	50			
Collector-emitter saturation voltage	V <sub>CE(sat)</sub>	I <sub>C</sub> =-10mA, I <sub>B</sub> =-1mA			-0.2	V
		I <sub>C</sub> =-50mA, I <sub>B</sub> =-5mA			-0.5	V
Base-emitter saturation voltage	V <sub>BE(sat)</sub>	I <sub>C</sub> =-10mA, I <sub>B</sub> =-1mA			-1	V
		I <sub>C</sub> =-50mA, I <sub>B</sub> =-5mA			-1	V
Output Capacitance	C <sub>obo</sub>	V <sub>CB</sub> =-10V, f = 1.0MHz, I <sub>E</sub> = 0			6.0	pF
Current Gain-Bandwidth Product	f <sub>T</sub>	V <sub>CE</sub> =-10V, I <sub>C</sub> =-10mA, f = 100MHz	100		300	MHz
Noise Figure	NF	V <sub>CE</sub> =-5.0V, I <sub>C</sub> =-200μA, R <sub>S</sub> = 10 Ω , f = 1.0kHz			8.0	dB



Characteristics Curves (NPN 5551)

Fig.1 Static Characteristic

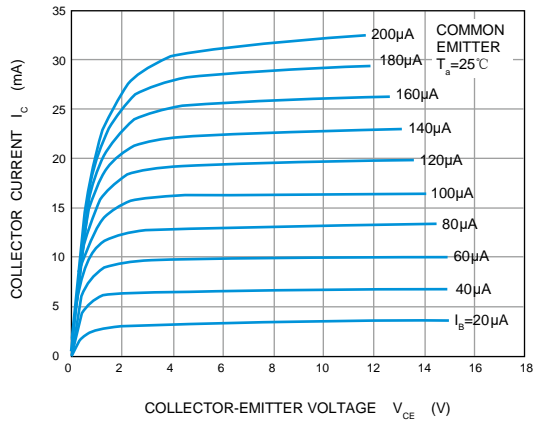

Fig.2  $h_{FE}$  vs  $I_c$

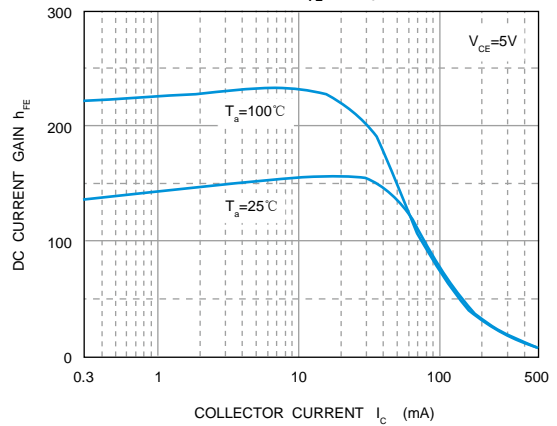

Fig.3  $V_{BEsat}$  vs  $I_c$

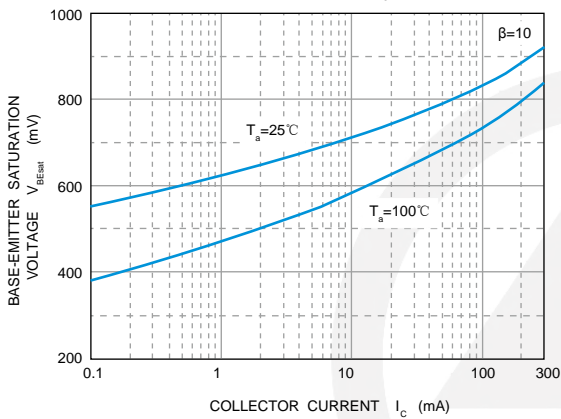

Fig.4  $V_{CEsat}$  vs  $I_c$

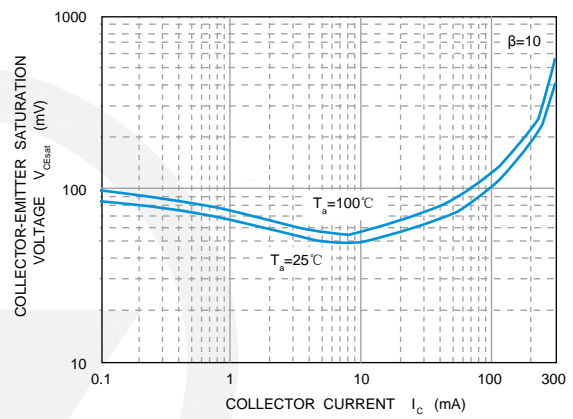

Fig.5  $C_{ob}/C_{ib}$  vs  $V_{CB}/V_{EB}$

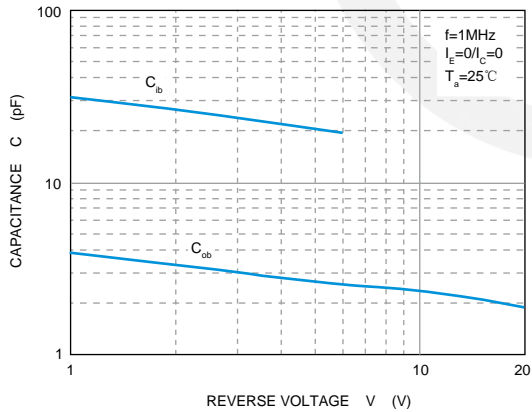

Fig.6  $f_T$  vs  $I_c$

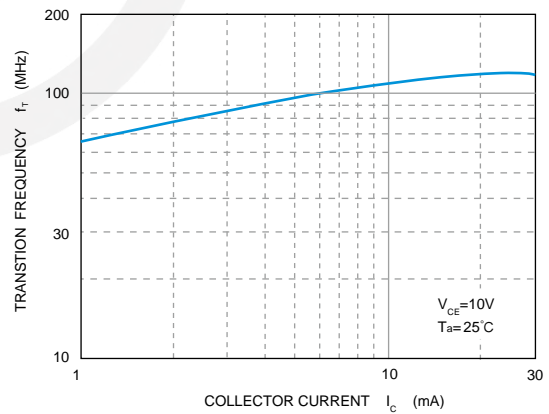
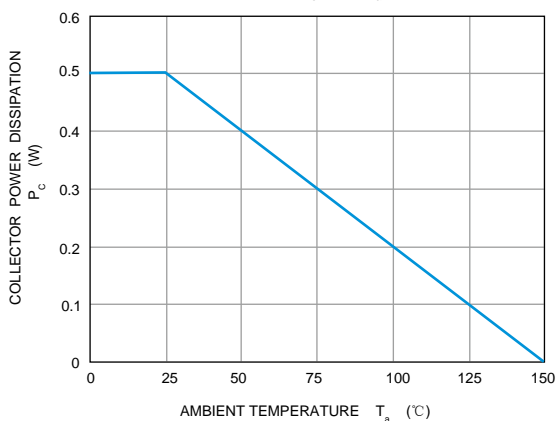

Fig.7  $P_c$  vs  $T_a$





Characteristics Curves (PNP 5401)

Fig.1 Static Characteristic

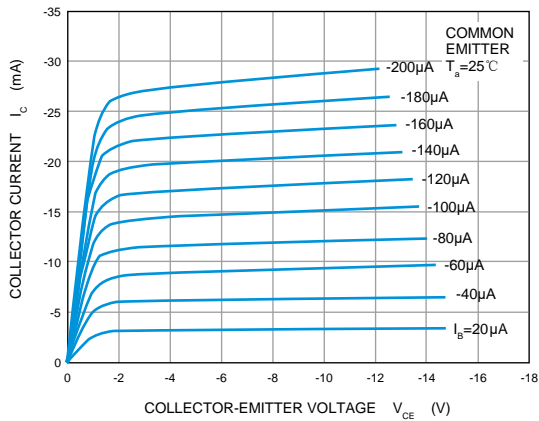

Fig.2  $h_{FE}$  vs  $I_c$

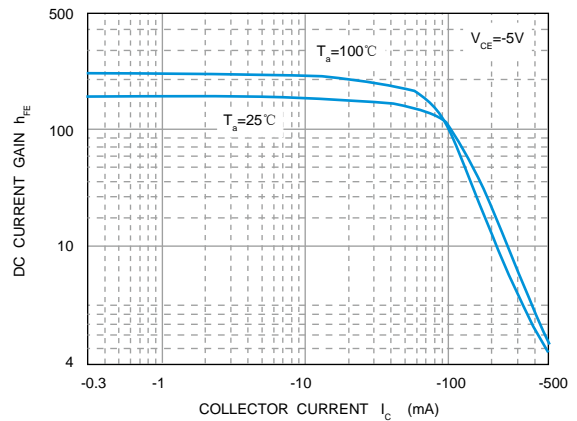

Fig.3  $V_{BEsat}$  vs  $I_c$

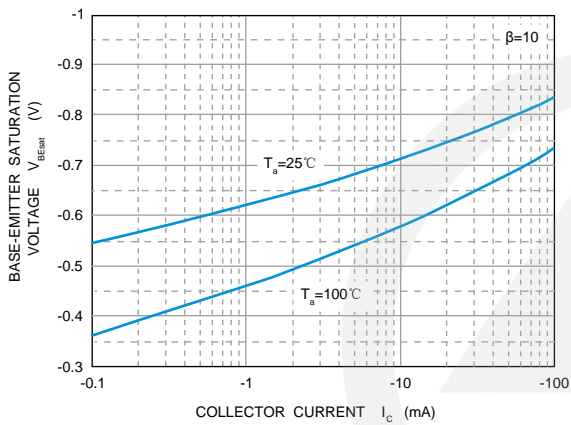

Fig.4  $V_{CEsat}$  vs  $I_c$

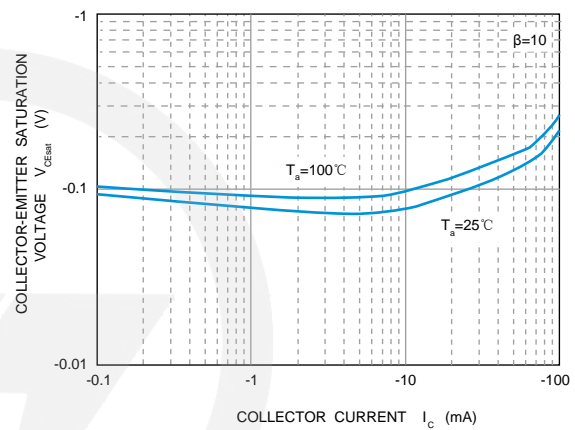

Fig.5  $C_{ob}/C_{ib}$  vs  $V_{CB}/V_{EB}$

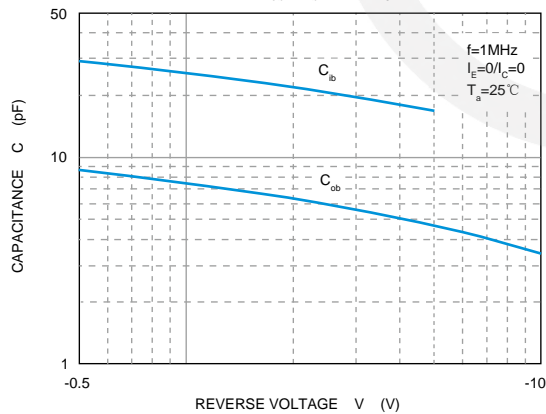

Fig.6  $f_T$  vs  $I_c$

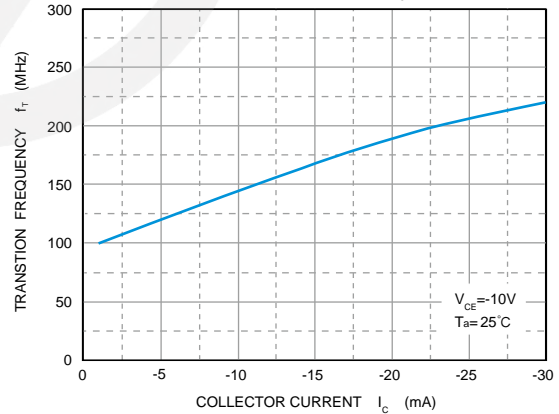
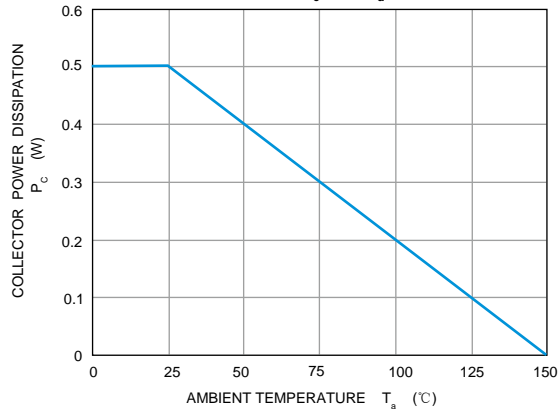
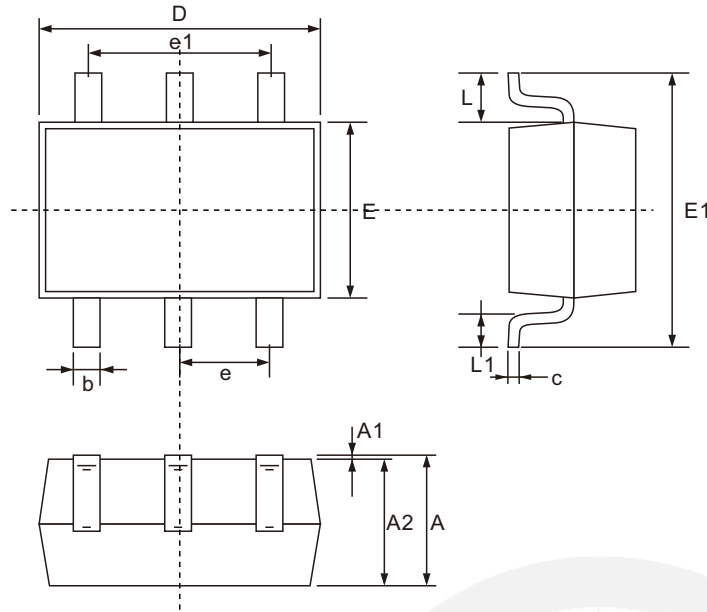

Fig.7  $P_c$  vs  $T_a$





SOT-363 Package Outline



Unit: mm

SYMBOL	DIMENSIONS	
	MIN.	MAX.
A	0.900	1.100
A1	0.000	0.100
A2	0.900	1.000
b	0.150	0.350
c	0.080	0.150
D	2.000	2.200
E	1.150	1.350
E1	2.150	2.450
e	0.650 TYP.	
e1	1.200	1.400
L	0.525 TYP.	
L1	0.260	0.460
θ	0°	8°

SOT-363 Suggested Pad Layout

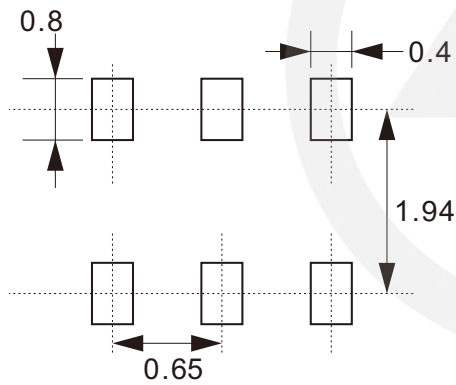

Note:  
1. Controlling dimension: in millimeters.  
2. General tolerance:  $\pm 0.05$  mm  
3. The pad layout is for reference purpose only.

## Carrier Tape Dimensions

Unit : mm

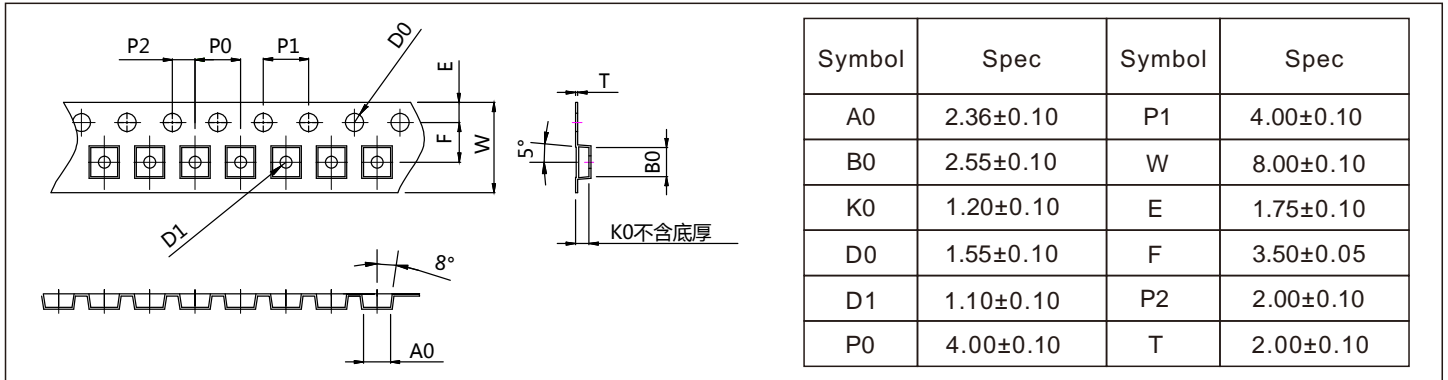

## Reel Dimensions

Unit : mm

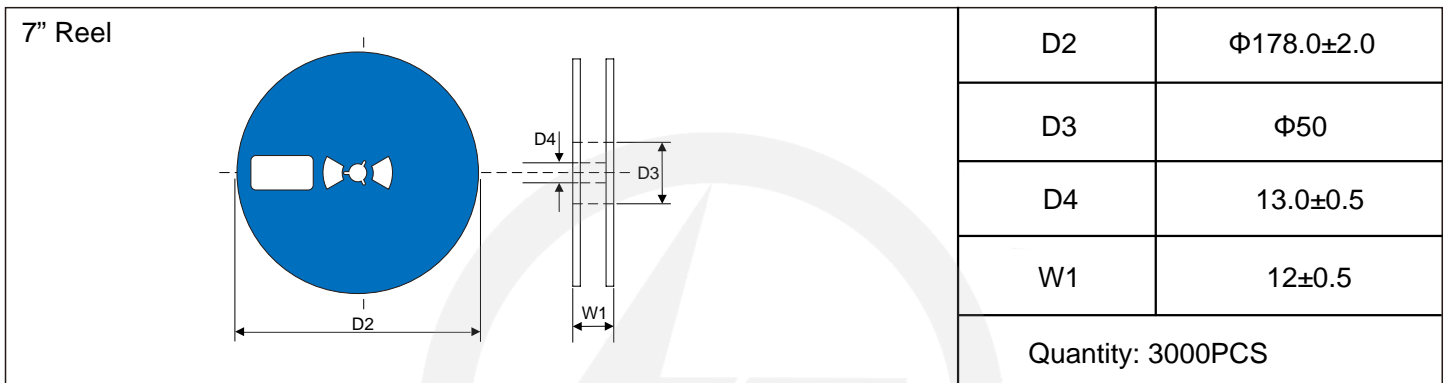

## Reel Dimensions

Unit : mm

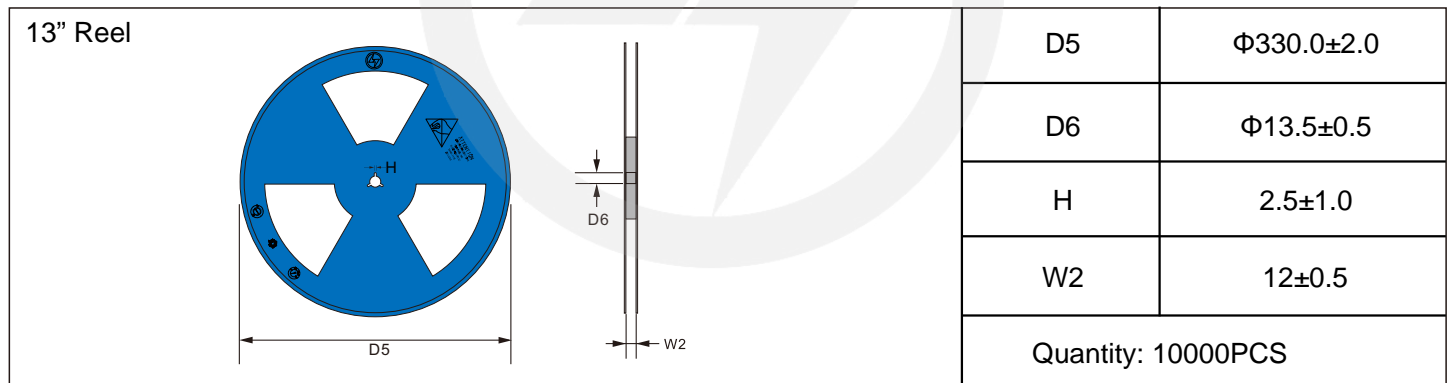

## Packaging

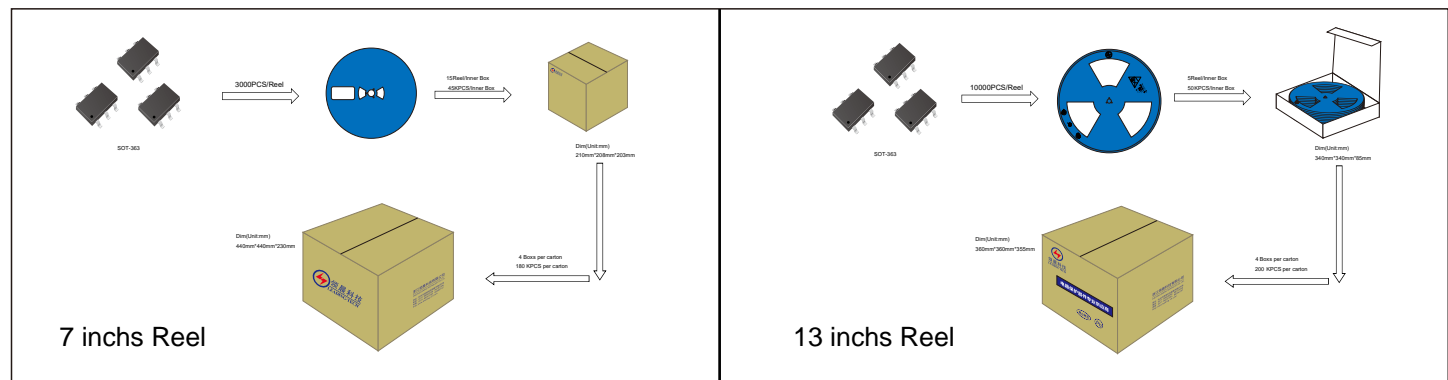



Recommended Soldering Conditions

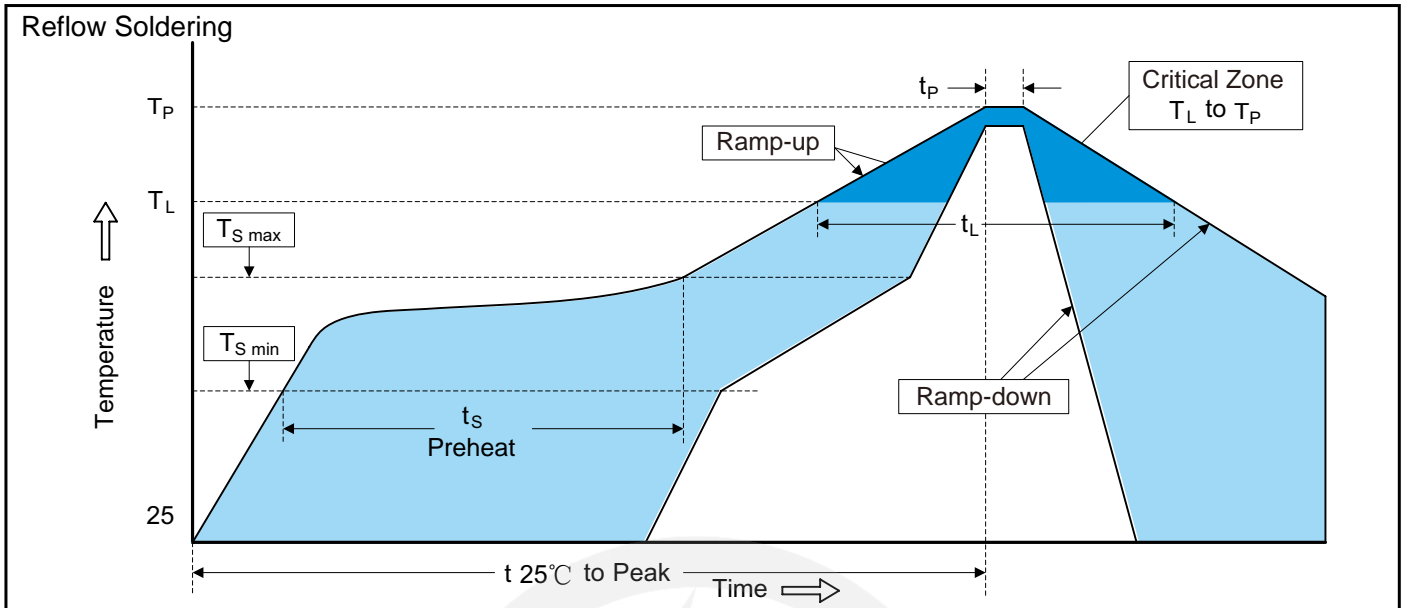

Recommended Conditions

Profile Feature	Pb-Free Assembly
Average ramp-up rate (T <sub>L</sub> to T <sub>P</sub> )	3°C/second max.
Preheat	
-Temperature Min (T <sub>S min</sub> )	150°C
-Temperature Max (T <sub>S max</sub> )	200°C
-Time (min to max) (t <sub>s</sub> )	60-180 seconds
T <sub>S max</sub> to T <sub>L</sub>	
-Ramp-up Rate	3°C/second max.
Time maintained above:	
-Temperature (T <sub>L</sub> )	217°C
-Time (t <sub>L</sub> )	60-150 seconds
Peak Temperature (T <sub>P</sub> )	260°C
Time within 5°C of actual Peak Temperature (t <sub>p</sub> )	20-40 seconds
Ramp-down Rate	6°C/second max.
Time 25°C to Peak Temperature	8 minutes max.

## Important Notice and Disclaimer

Leading-Tech reverses the right to make changes to this document and its products and specifications at any time without notice.

Customers should obtain and confirm the latest product information and specifications before final design, purchase or use.

Leading-Tech makes no warranty, representation or guarantee regarding the suitability of its products for any particular purpose, not does Leading-Tech assume any liability for application assistance or customer product design.

Leading-tech does not warrant or accept any liability with products which are purchase or used for any unintended or unauthorized application.

No license is granted by implication or otherwise under any intellectual property rights of Leading-Tech.

Leading-Tech products are not authorized for use as critical components in life support devices or systems without express written approval of Leading-tech.

## Version Update Information

Series NO.	Enactment/Revision Date	Effective Date	Version	Revision content	Revision Reason	Revision Person	Note
01	2024.10.08	2024.10.08	3.0	New File	/	Ding	
02	2025.06.11	2025.06.11	3.1	Update packaging information	/	Ding	