

Transistor (NPN)

Features

- For AF driver and output stages
- High collector current
- Low collector-emitter saturation voltage
- Lead free in comply with EU RoHS 2011/65/EU directives

Ordering Information

Part Number	Shipping	Reel
LTBCX56-TR1	1000PCS Tape&Reel	7 inches
LTBCX56-TR3	3000PCS Tape&Reel	13 inches

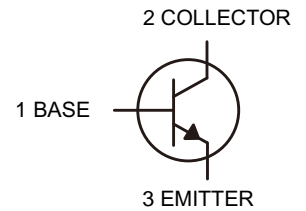
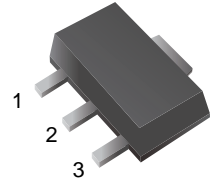

Absolute Maximum Ratings

Parameter	Symbol	Value	Units
Collector Base Voltage	V_{CBO}	100	V
Collector Emitter Voltage	V_{CEO}	80	V
Emitter Base Voltage	V_{EBO}	5	V
Collector Current	I_C	1	A
Peak Collector Current	I_{CM}	1.5	A
Total Power Dissipation	P_{tot}	0.5 ⁽¹⁾ 1.3 ⁽²⁾	W
Thermal Resistance, Junction-to-Ambient Junction-to-Case	$R_{\theta JA}$ $R_{\theta JC}$	225 50	°C/W °C/W
Junction Temperature	T_J	-55 ~ +150	°C
Storage Temperature Range	T_{stg}	-55 ~ +150	°C

Note :1. Device mounted on an FR4 Printed-Circuit Board(PCB), single-sided copper, tin-plated and standard footprint.

2. Device mounted on an FR4 PCB, single-sided copper, tin-plated, mounting pad for collector 6 cm²

Electrical Characteristics (TA=25°C unless otherwise specified)

Parameter	Symbol	Min	Typ	Max	Units
DC Current Gain					
at $V_{CE} = 2V, I_C = 5mA$	h_{FE}	40			
at $V_{CE} = 2V, I_C = 150mA$	LTBCX56-10 h_{FE}	63		160	
	LTBCX56-16 h_{FE}	100		250	
at $V_{CE} = 2V, I_C = 500mA$	h_{FE}	25			
Collector Base Cutoff Current at $V_{CB} = 30V$	I_{CBO}			0.1	μA
Collector Emitter Cutoff Current at $V_{CE} = 80V, I_B=0$	I_{CEO}			10	μA
Emitter Base Cutoff Current at $V_{EB} = 5V$	I_{EBO}			0.1	μA
Collector Base Breakdown Voltage at $I_C = 100\mu A$	$V_{(BR)CBO}$	100			V
Collector Emitter Breakdown Voltage at $I_C = 1mA$	$V_{(BR)CEO}$	80			V
Emitter Base Breakdown Voltage at $I_E = 100\mu A$	$V_{(BR)EBO}$	5			V
Collector Emitter Saturation Voltage at $I_C = 500mA, I_B = 50mA$	$V_{CE(sat)}$			0.5	V
Base Emitter Voltage at $V_{CE} = 2V, I_C = 500mA$	V_{BE}			1	V
Transition Frequency at $V_{CE} = 5V, I_C = 50mA, f = 100MHz$	f_T	100			MHz
Collector Capacitance at $V_{CB} = 15V, f = 1MHz$	C_c		6		pF



Characteristics Curves

Fig.1 Static Characteristic

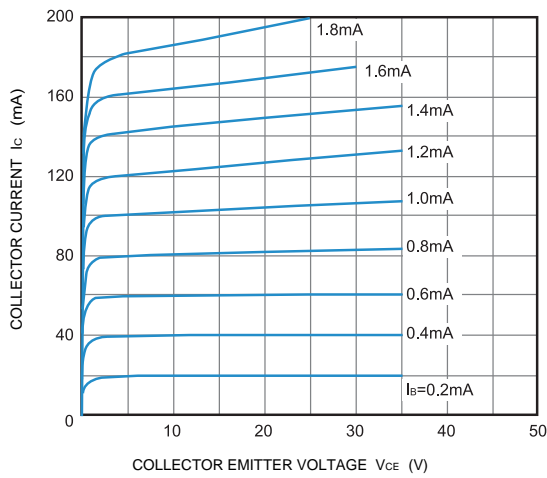

Fig.2 DC Current Gain

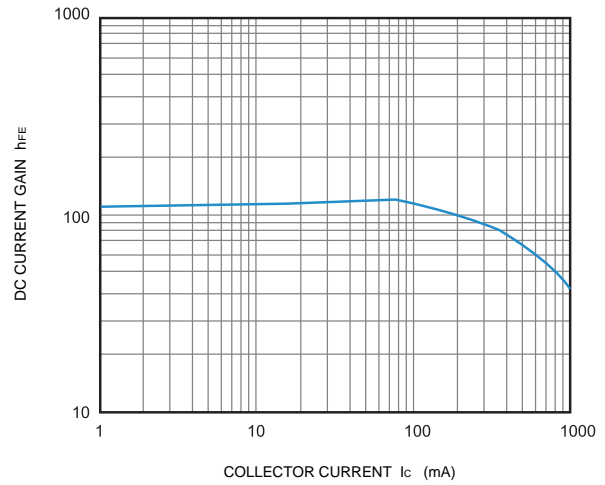

Fig.3 Base Emitter Saturation Voltage
Collector Emitter Saturation Voltage

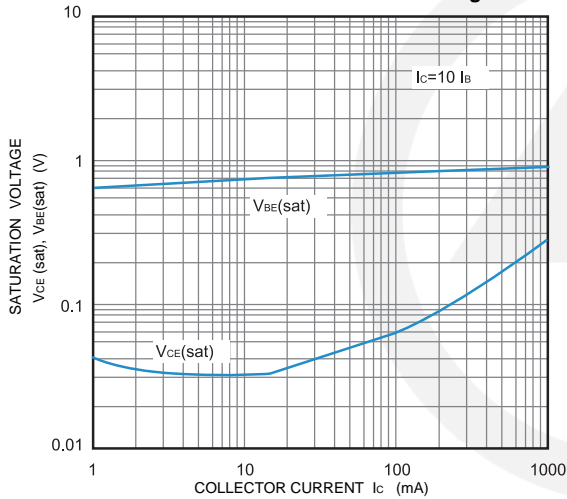

Fig.4 Base Emitter On Voltage

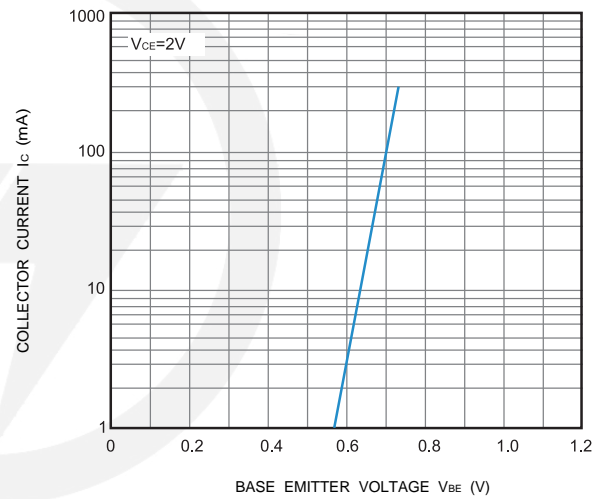

Fig.5 Collector Output Characteristic

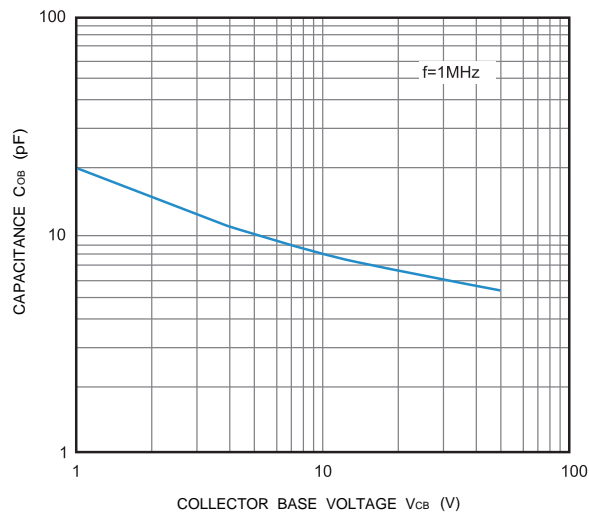
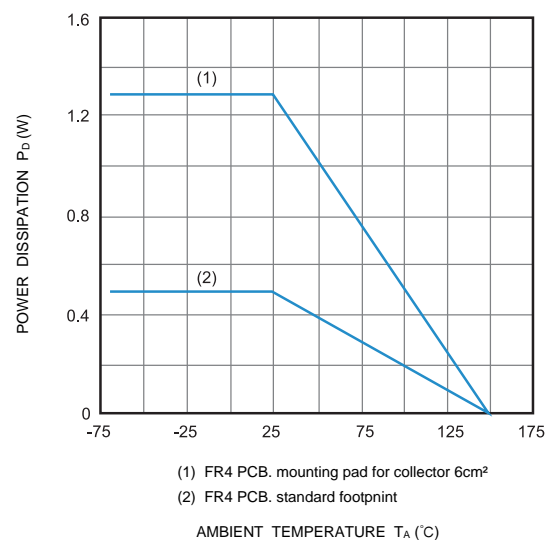
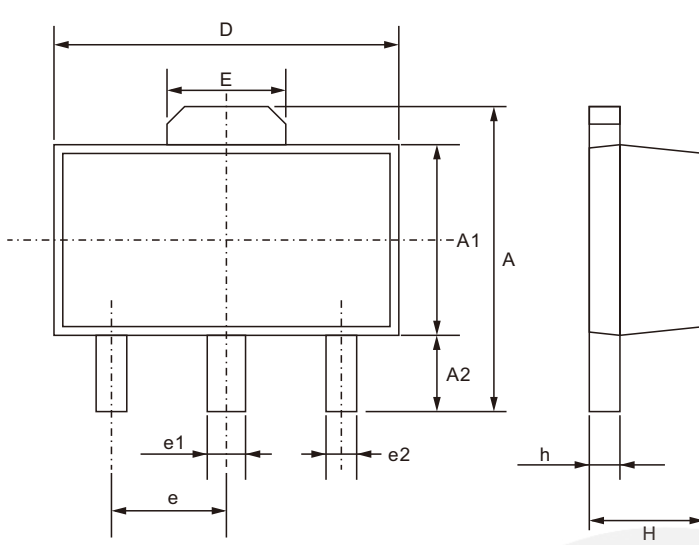

Fig.6 Power Derating Curves



SOT-89 Package Outline



Unit: mm

SYMBOL	DIMENSIONS	
	MIN.	MAX.
A	3.750	4.250
A1	2.400	2.600
A2	0.950	1.050
D	4.400	4.600
E	1.500	1.600
e1	0.470	0.530
e2	0.350	0.450
e	1.500 TYP.	
H	1.400	1.600
h	0.300	0.500



Carrier Tape Dimensions

Unit : mm

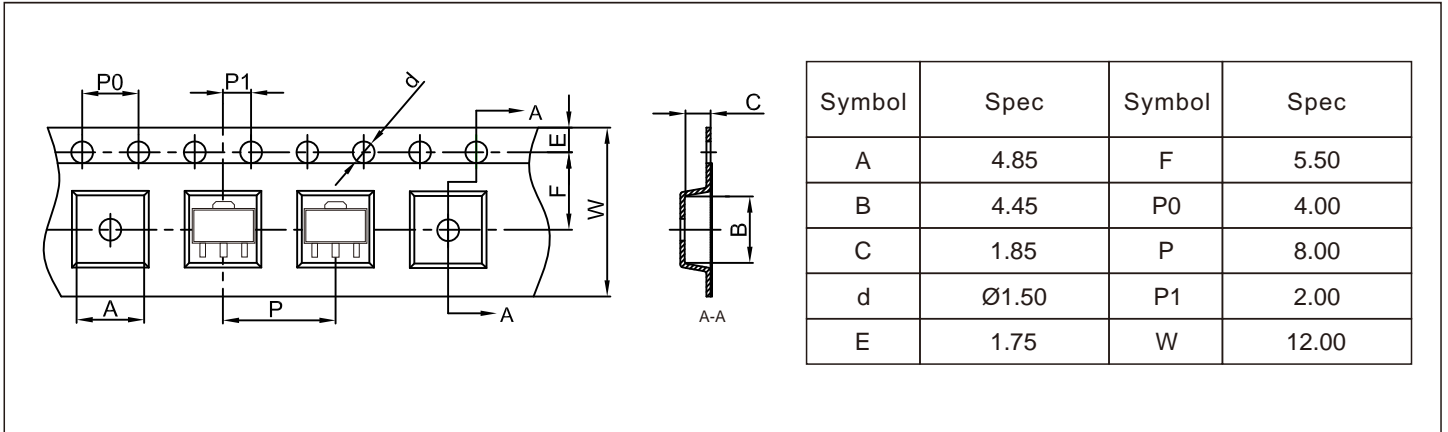

Reel Dimensions

Unit : mm

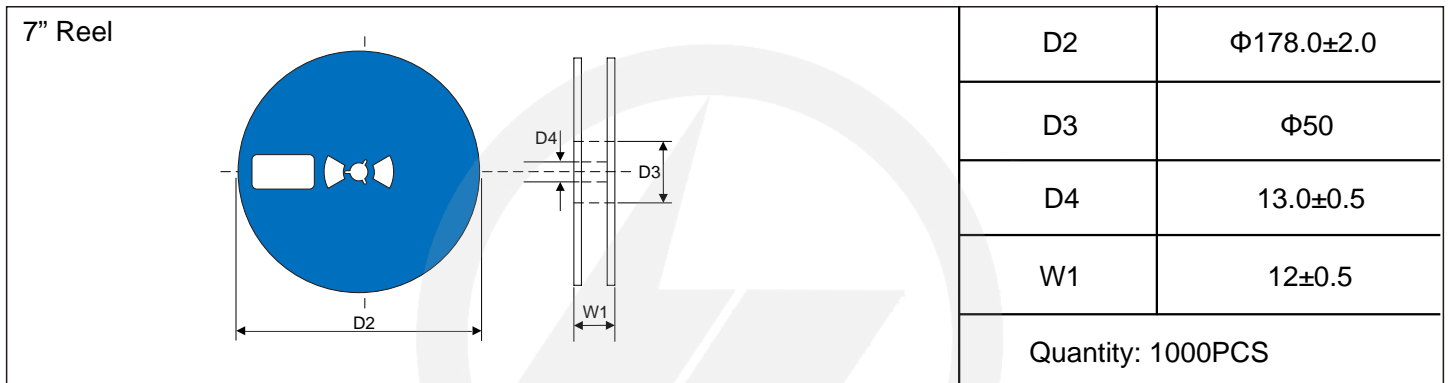

Reel Dimensions

Unit : mm

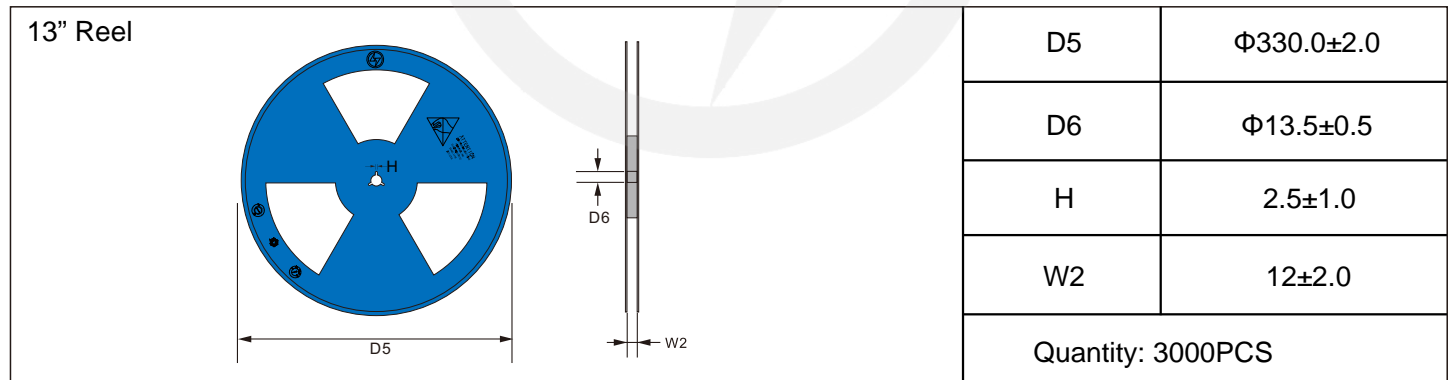

Packaging

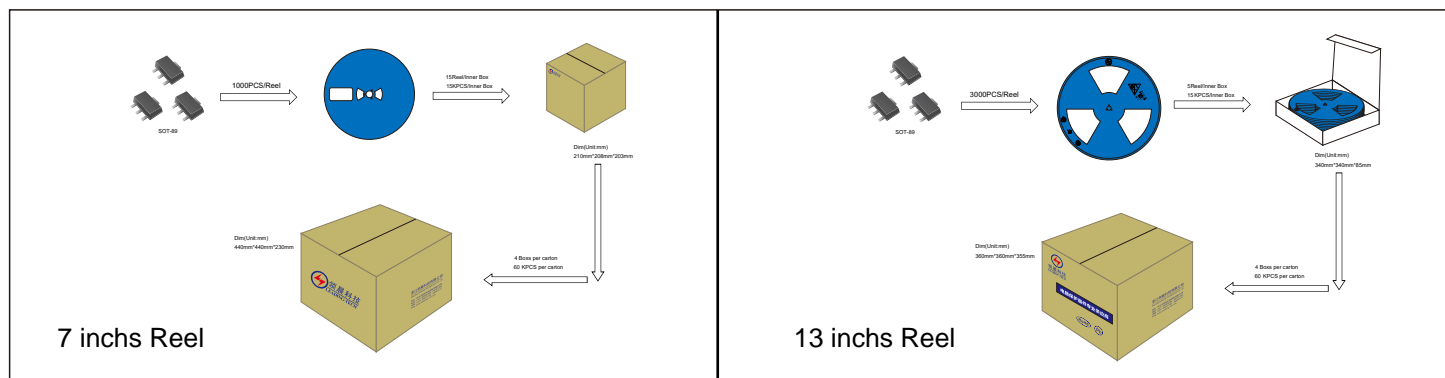



Recommended Soldering Conditions

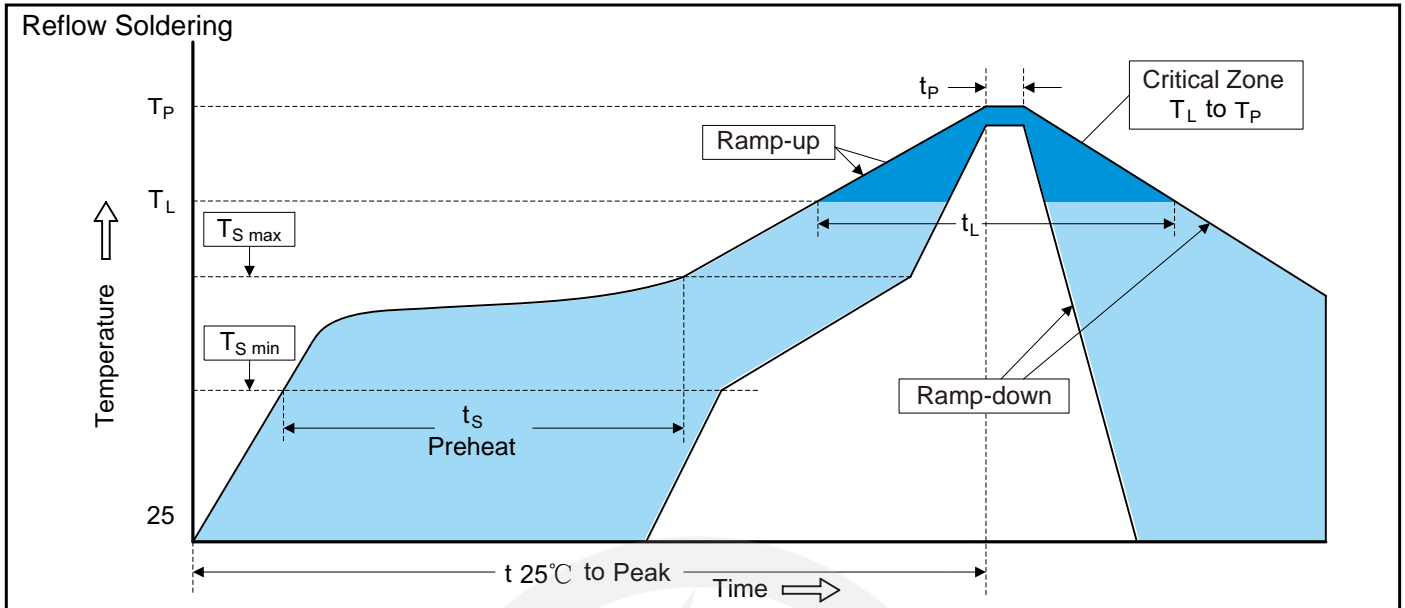

Recommended Conditions

Profile Feature	Pb-Free Assembly
Average ramp-up rate (T _L to T _P)	3°C/second max.
Preheat	
-Temperature Min (T _{S min})	150°C
-Temperature Max (T _{S max})	200°C
-Time (min to max) (t _s)	60-180 seconds
T _{S max} to T _L	
-Ramp-up Rate	3°C/second max.
Time maintained above:	
-Temperature (T _L)	217°C
-Time (t _L)	60-150 seconds
Peak Temperature (T _P)	260°C
Time within 5°C of actual Peak Temperature (t _p)	20-40 seconds
Ramp-down Rate	6°C/second max.
Time 25°C to Peak Temperature	8 minutes max.

Important Notice and Disclaimer

Leading-Tech reserves the right to make changes to this document and its products and specifications at any time without notice.

Customers should obtain and confirm the latest product information and specifications before final design, purchase or use.

Leading-Tech makes no warranty, representation or guarantee regarding the suitability of its products for any particular purpose, not does Leading-Tech assume any liability for application assistance or customer product design.

Leading-tech does not warrant or accept any liability with products which are purchase or used for any unintended or unauthorized application.

No license is granted by implication or otherwise under any intellectual property rights of Leading-Tech.

Leading-Tech products are not authorized for use as critical components in life support devices or systems without express written approval of Leading-tech.

Version Update Information

Series NO.	Enactment/Revision Date	Effective Date	Version	Revision content	Revision Reason	Revision Person	Note
01	2024.9.4	2024.9.4	3.0	New File	/	Ding	
02	2025.06.12	2025.06.12	3.1	1. Add Absolute Maximum Ratings information 2. Add Electrical Characteristics information	/	Ding	