

Surface Mount Bridge Rectifier

Features

- Reverse Voltage 40 to 200 V
- Forward Current 1 A
- High Surge Current Capability
- Designed for Surface Mount Application
- Lead free in comply with EU RoHS 2011/65/EU directives

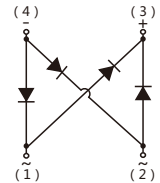
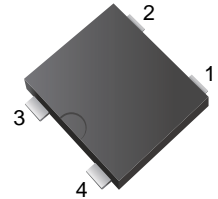

Mechanical Data

- Case:LTB
- Terminal:Leads solderable per MIL-STD-750 Method 2026

Ordering Information

Part Number	Shipping	Reel
LTB14S THRU LTB120S	5000PCS Tape&Reel	13 inches



Maximum Ratings and Electrical Characteristics

Ratings at 25°C ambient temperature unless otherwise specified.
 Single phase half-wave 60Hz, resistive or inductive load, for capacitive load current derate by 20%.

Parameter	Symbol	LTB14S	LTB16S	LTB18S	LTB110S	LTB115S	LTB120S	Unit
	Marking	LTB14S	LTB16S	LTB18S	LTB110S	LTB115S	LTB120S	
Maximum Repetitive Peak Reverse Voltage	V_{RRM}	40	60	80	100	150	200	V
Maximum RMS voltage	V_{RMS}	28	42	56	70	105	140	V
Maximum DC Blocking Voltage	V_{DC}	40	60	80	100	150	200	V
Maximum Average Forward Rectified Current at $T_c = 100^\circ\text{C}$	$I_{F(AV)}$	1						A
Peak Forward Surge Current, 8.3ms Single Half Sine-wave Superimposed on Rated Load (JEDEC method)	I_{FSM}	30						A
Max Instantaneous Forward Voltage at 1 A	V_F	0.55	0.70	0.85		0.90		V
Maximum DC Reverse Current $T_a = 25^\circ\text{C}$ at Rated DC Reverse Voltage $T_a = 100^\circ\text{C}$	I_R	0.3 10		0.2 5		0.1 2		mA
Typical Junction Capacitance (Note1)	C_J	110	80					pF
Typical Thermal Resistance (Note2)	$R_{\theta JA}$	100						$^\circ\text{C}/\text{W}$
Operating Junction Temperature Range	T_J	-55 ~ +125						$^\circ\text{C}$
Storage Temperature Range	T_{stg}	-55 ~ +150						$^\circ\text{C}$

Note:(1) Measured at 1MHz and applied reverse voltage of 4V D.C.

(2) Mounted on glass epoxy PC board with 4×1.5"×1.5" (3.81cm×3.81cm) copper pad.



Characteristic Curves

FIG.1 FORWARD CURRENT DERATING CURVE

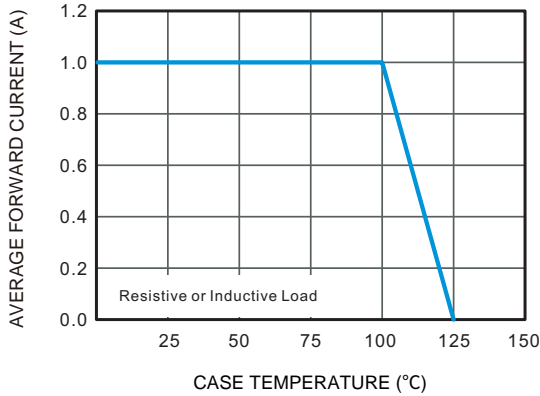

FIG. 2 TYPICAL REVERSE CHARACTERISTICS

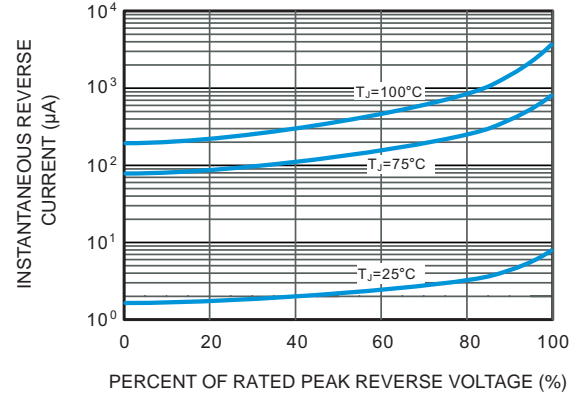

FIG. 3 TYPICAL INSTANTANEOUS FORWARD CHARACTERISTICS

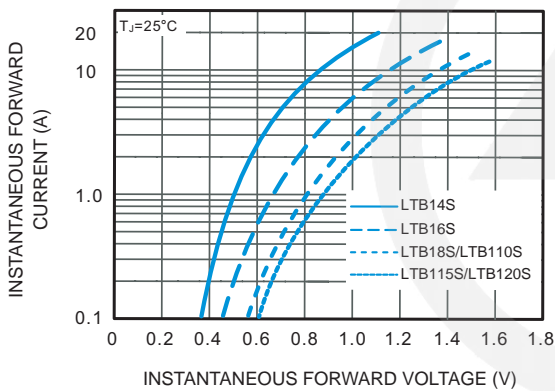

FIG. 4 TYPICAL JUNCTION CAPACITANCE

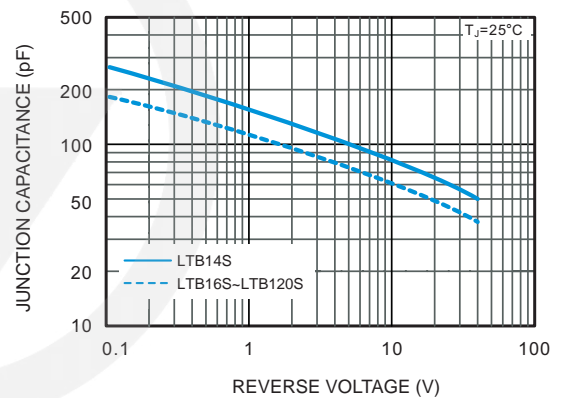

FIG. 2 MAXIMUM NON-REPETITIVE PEAK FORWARD SURGE CURRENT

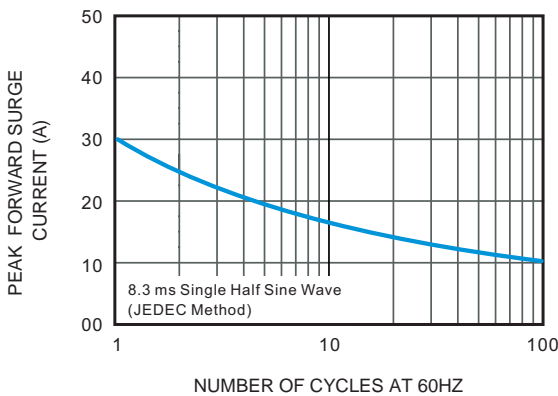
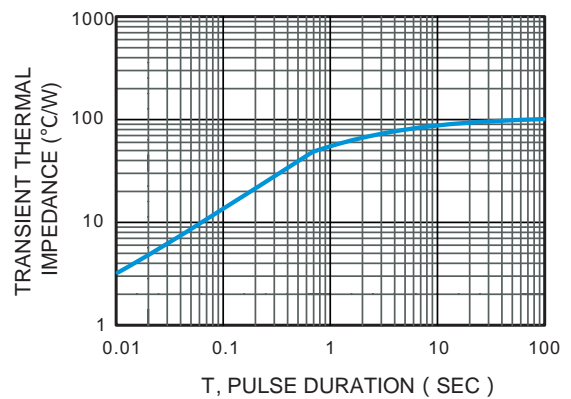
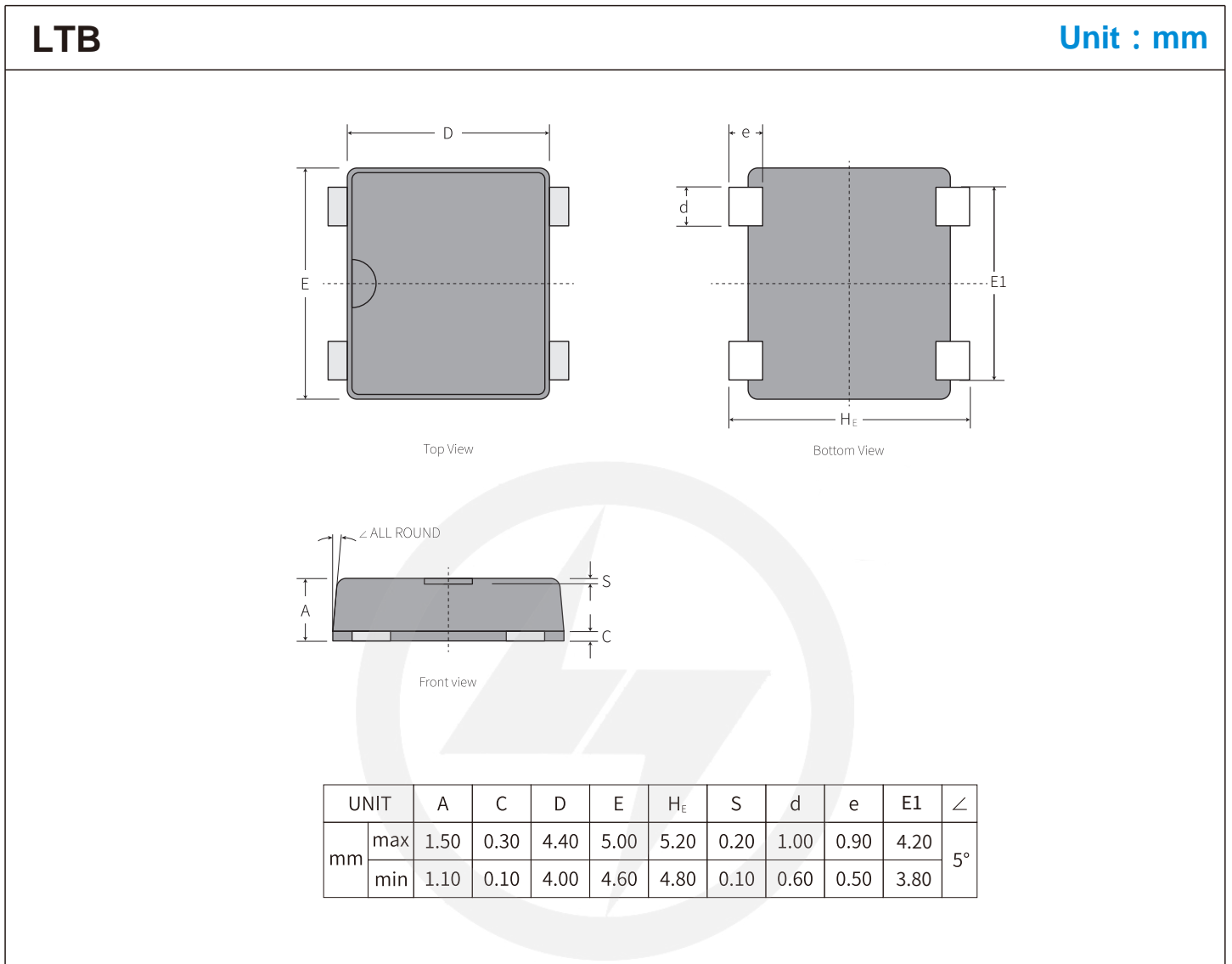

FIG.6 TYPICAL TRANSIENT THERMAL IMPEDANCE



Package Outline



Suggested Pad Layout

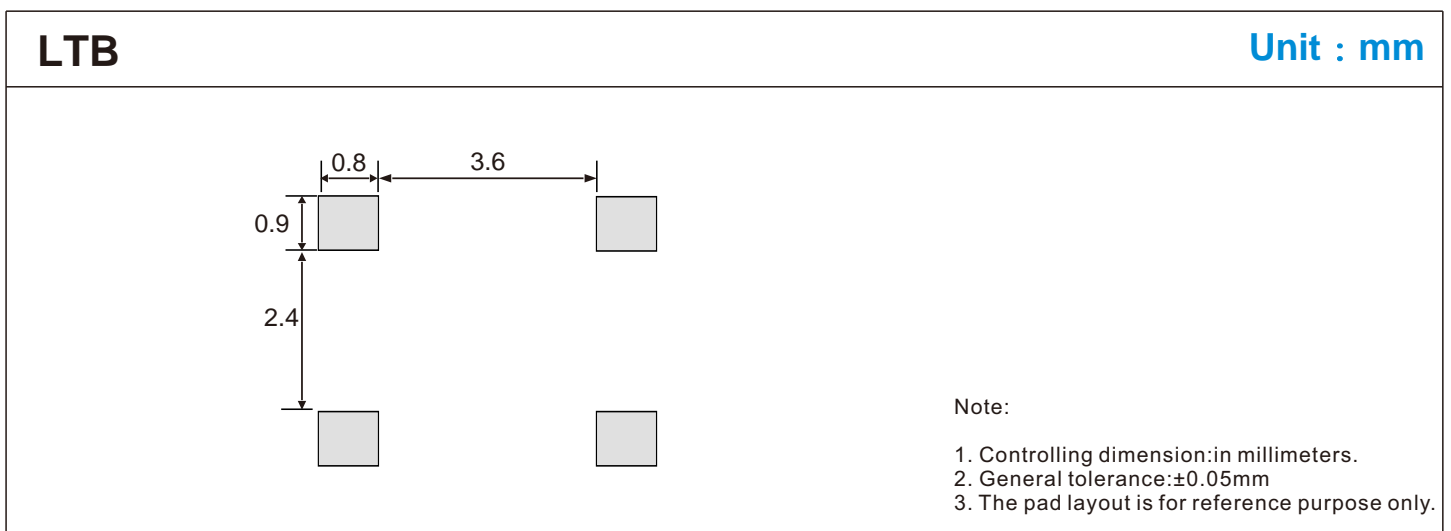

Carrier Tape Dimensions

Unit : mm

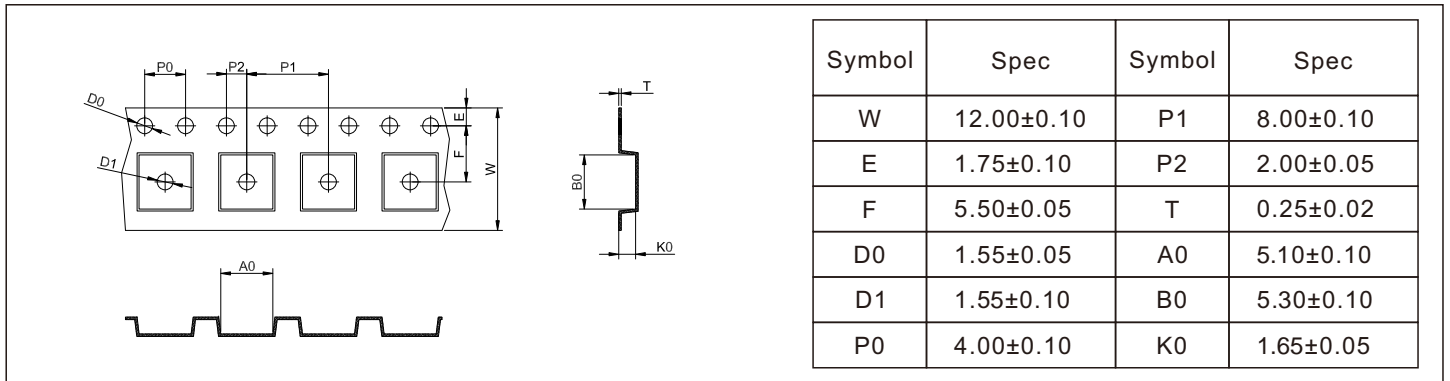

Reel Dimensions

Unit : mm

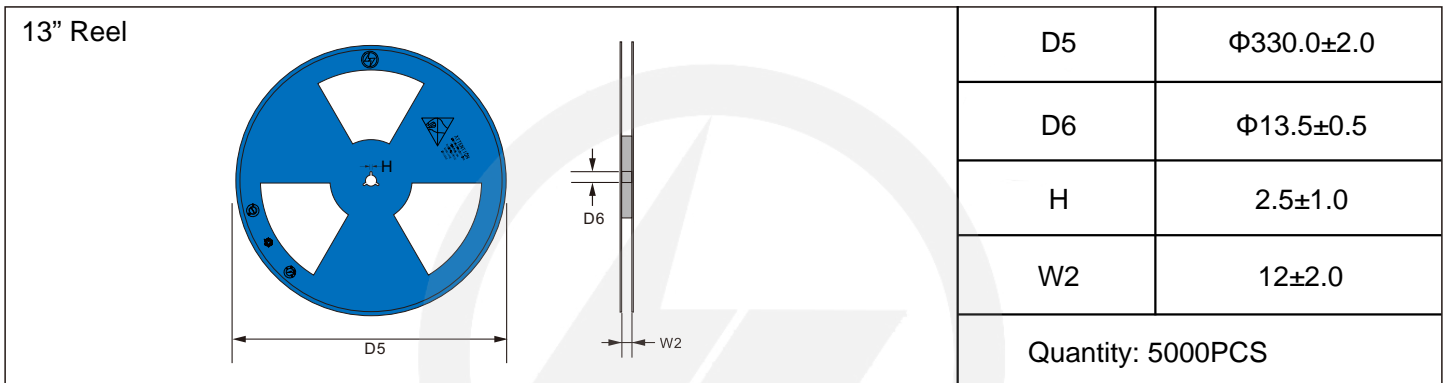

Packaging

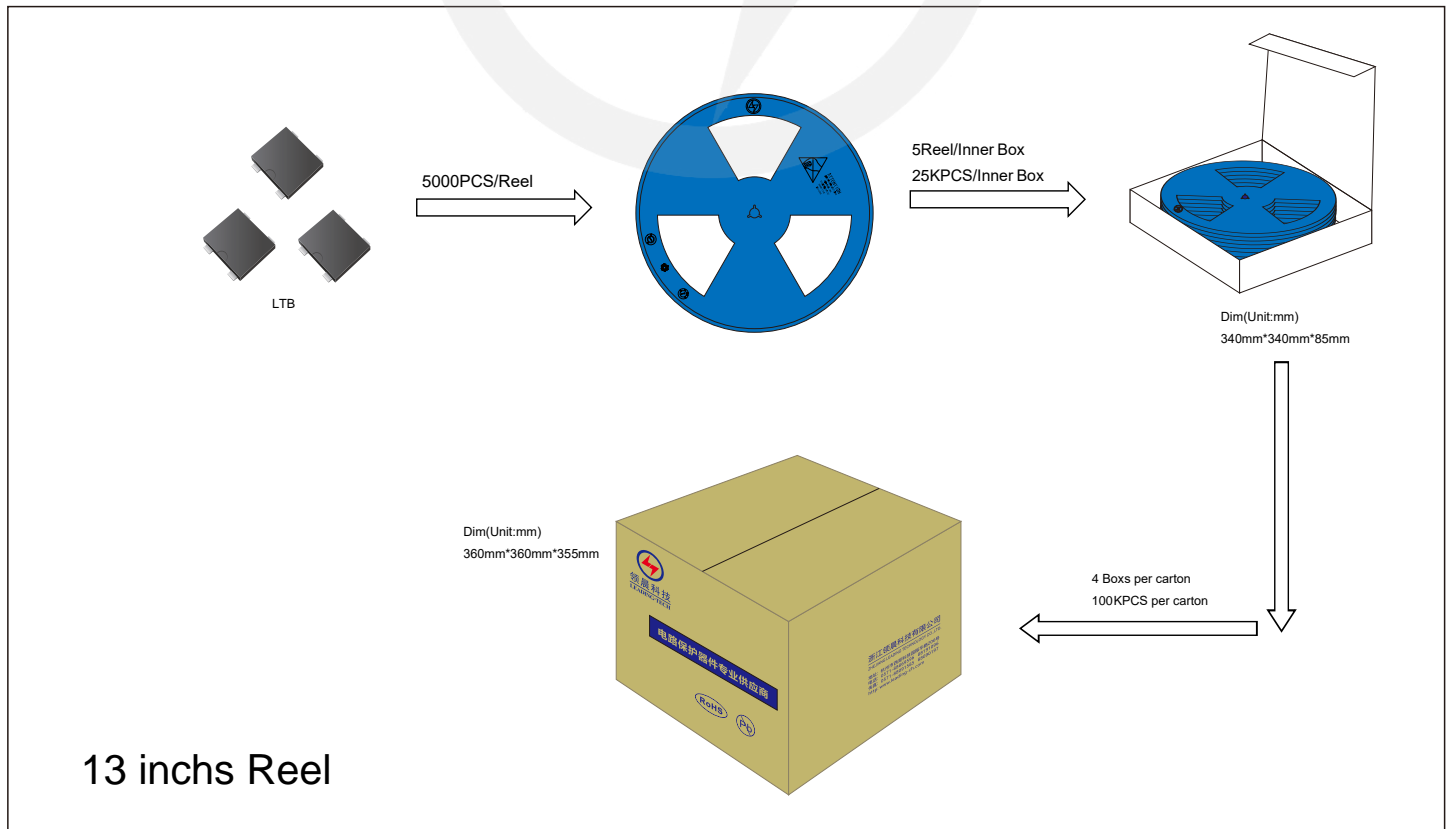



Recommended Soldering Conditions



Recommended Conditions

Profile Feature	Pb-Free Assembly
Average ramp-up rate (T _L to T _P)	3°C/second max.
Preheat	
-Temperature Min (T _{S min})	150°C
-Temperature Max (T _{S max})	200°C
-Time (min to max) (t _s)	60-180 seconds
T _{S max} to T _L	
-Ramp-up Rate	3°C/second max.
Time maintained above:	
-Temperature (T _L)	217°C
-Time (t _L)	60-150 seconds
Peak Temperature (T _P)	260°C
Time within 5°C of actual Peak Temperature (t _p)	20-40 seconds
Ramp-down Rate	6°C/second max.
Time 25°C to Peak Temperature	8 minutes max.

Important Notice and Disclaimer

Leading-Tech reserves the right to make changes to this document and its products and specifications at any time without notice.

Customers should obtain and confirm the latest product information and specifications before final design, purchase or use.

Leading-Tech makes no warranty, representation or guarantee regarding the suitability of its products for any particular purpose, not does Leading-Tech assume any liability for application assistance or customer product design.

Leading-Tech does not warrant or accept any liability with products which are purchase or used for any unintended or unauthorized application.

No license is granted by implication or otherwise under any intellectual property rights of Leading-Tech.

Leading-Tech products are not authorized for use as critical components in life support devices or systems without express written approval of Leading-tech.

Version Update Information

Series NO.	Enactment/Revision Date	Effective Date	Version	Revision content	Revision Reason	Revision Person	Note
01	2024.3.17	2024.3.17	1.0	New File	/	Ding	
02	2025.06.21	2025.06.21	1.1	Update packaging information	/	Ding	
03	2025.07.15	2025.07.15	1.2	Revise IFSM=30A	/	Ding	
04	2025.07.30	2025.07.30	1.3	Update Suggested Pad Layout	/	Ding	