

1A Surface Mount Schottky Bridge

Features

- Reverse Voltage - 40 to 200 V
- Forward Current - 1A
- High Surge Current Capability
- Designed for Surface Mount Application
- Lead free in comply with EU RoHS 2011/65/EU directives

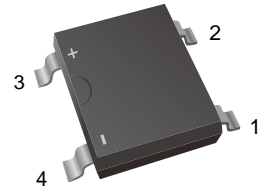

Mechanical Data

- Case: ABS
- Terminals: Solderable per MIL-STD-750, Method 2026
- Approx. Weight: 0.083g

Ordering Information

Part Number	Shipping	Reel
LTA14S THRU LTA120S-TR5	5000PCS Tape&Reel	13 inches

Maximum Ratings and Electrical Characteristics

Ratings at 25 °C ambient temperature unless otherwise specified.

Single phase half-wave 60 Hz, resistive or inductive load, for capacitive load current derate by 20 %.

Parameter	Symbols	LTA14S	LTA16S	LTA18S	LTA110S	LTA120S	Units
Maximum Repetitive Peak Reverse Voltage	V_{RRM}	40	60	80	100	200	V
Maximum RMS voltage	V_{RMS}	28	42	56	70	140	V
Maximum DC Blocking Voltage	V_{DC}	40	60	80	100	200	V
Maximum Average Forward Rectified Current	$I_{F(AV)}$	1.0					A
Peak Forward Surge Current, 8.3ms Single Half Sine-wave Superimposed on Rated Load (JEDEC method)	I_{FSM}	40		30			A
Max Instantaneous Forward Voltage at 1 A	V_F	0.55	0.70	0.85			V
Maximum DC Reverse Current at Rated DC Reverse Voltage $T_a = 25^{\circ}C$ $T_a = 100^{\circ}C$	I_R	0.3 10		0.2 5		0.1 2	mA
Typical Junction Capacitance ¹⁾	C_j	110	80				pF
Typical Thermal Resistance ²⁾	$R_{\theta JA}$	95					°C/W
Operating Junction Temperature Range	T_j	-55 to +150					°C
Storage Temperature Range	T_{stg}	-55 to +150					°C

Note: 1. Measured at 1MHz and applied reverse voltage of 4 V D.C.

2. Mounted on glass epoxy PC board with 4×1.5"×1.5" (3.81×3.81 cm) copper pad.



Characteristics Curves

Fig.1 Forward Current Derating Curve

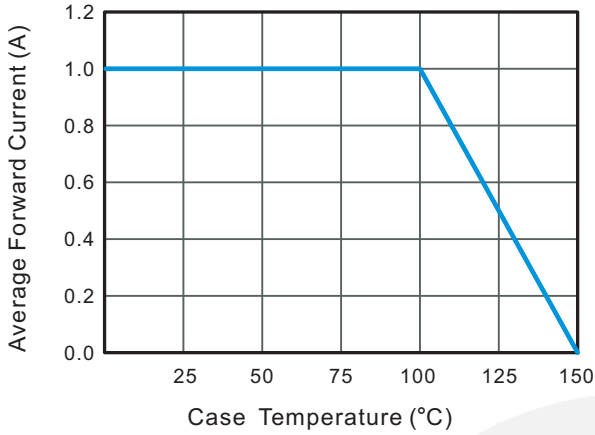

Fig.2 Typical Reverse Characteristics

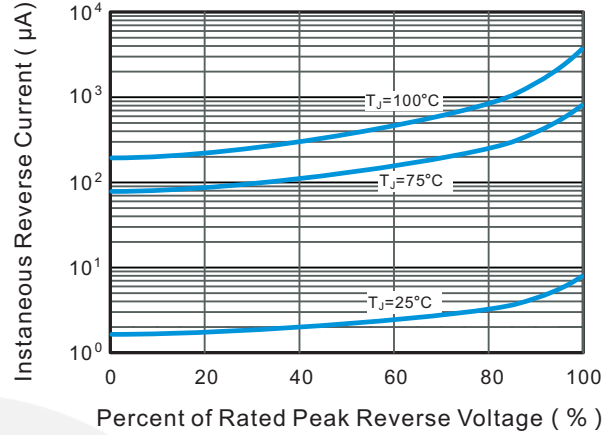

Fig.3 Typical Forward Characteristic

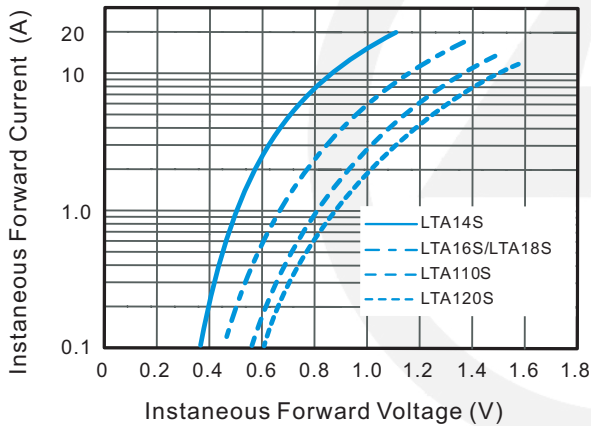

Fig.4 Typical Junction Capacitance

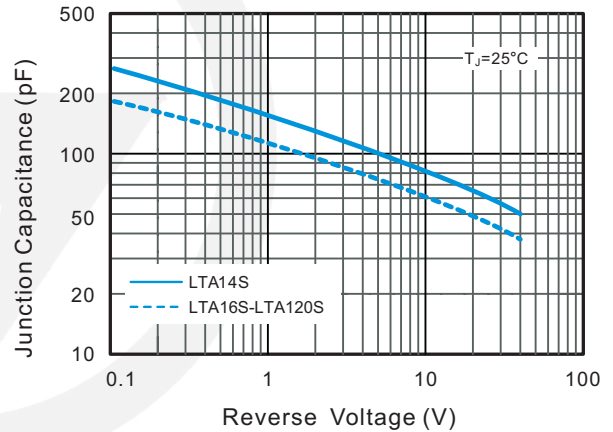

Fig.5 Maximum Non-Repetitive Peak Forward Surge Current

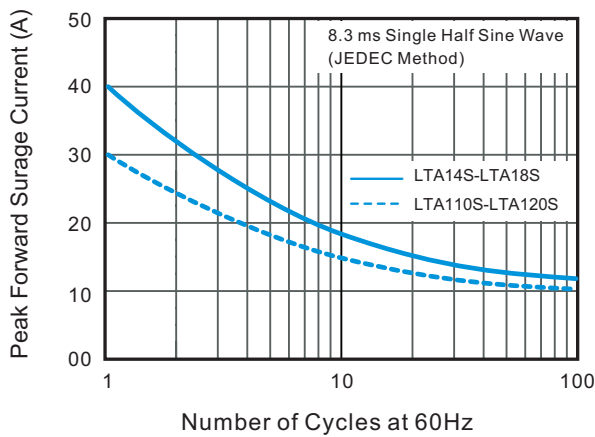
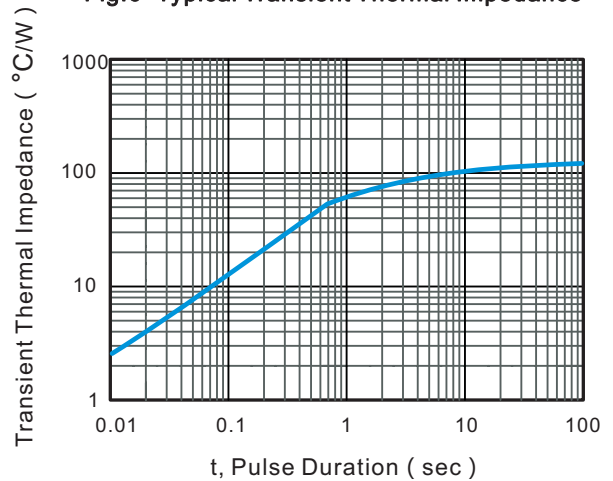
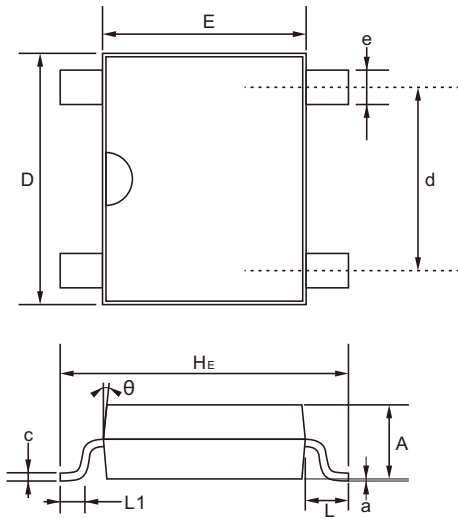

Fig.6 Typical Transient Thermal Impedance



ABS Package Outline



Unit: mm

SYMBOL	DIMENSIONS	
	MIN.	MAX.
A	1.300	1.500
C	0.150	0.220
D	4.900	5.200
E	4.200	4.500
HE	6.000	6.400
d	3.800	4.200
e	0.500	0.700
L	0.950 TYP.	
L1	0.600 TYP.	
a	0.200 TYP.	
θ	7°	

ABS Suggested Pad Layout

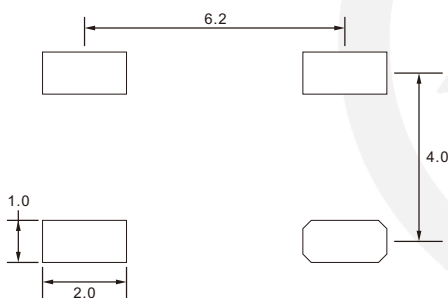

Note:

1. Controlling dimension: in millimeters.
2. General tolerance: $\pm 0.05\text{mm}$
3. The pad layout is for reference purpose only.

Marking

Type number	Marking code
LTA14S	TB14S
LTA16S	TB16S
LTA18S	TB18S
LTA110S	TB110S
LTA120S	TB120S

Reel Dimensions

Unit : mm

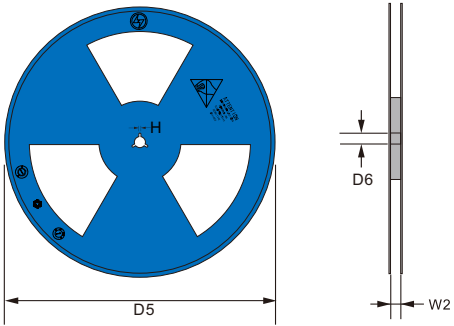
<p>13" Reel</p> 	D5	$\Phi 330.0 \pm 2.0$
	D6	$\Phi 13.5 \pm 0.5$
	H	2.5 ± 1.0
	W2	12 ± 2.0
	Quantity: 5000PCS	

Packaging

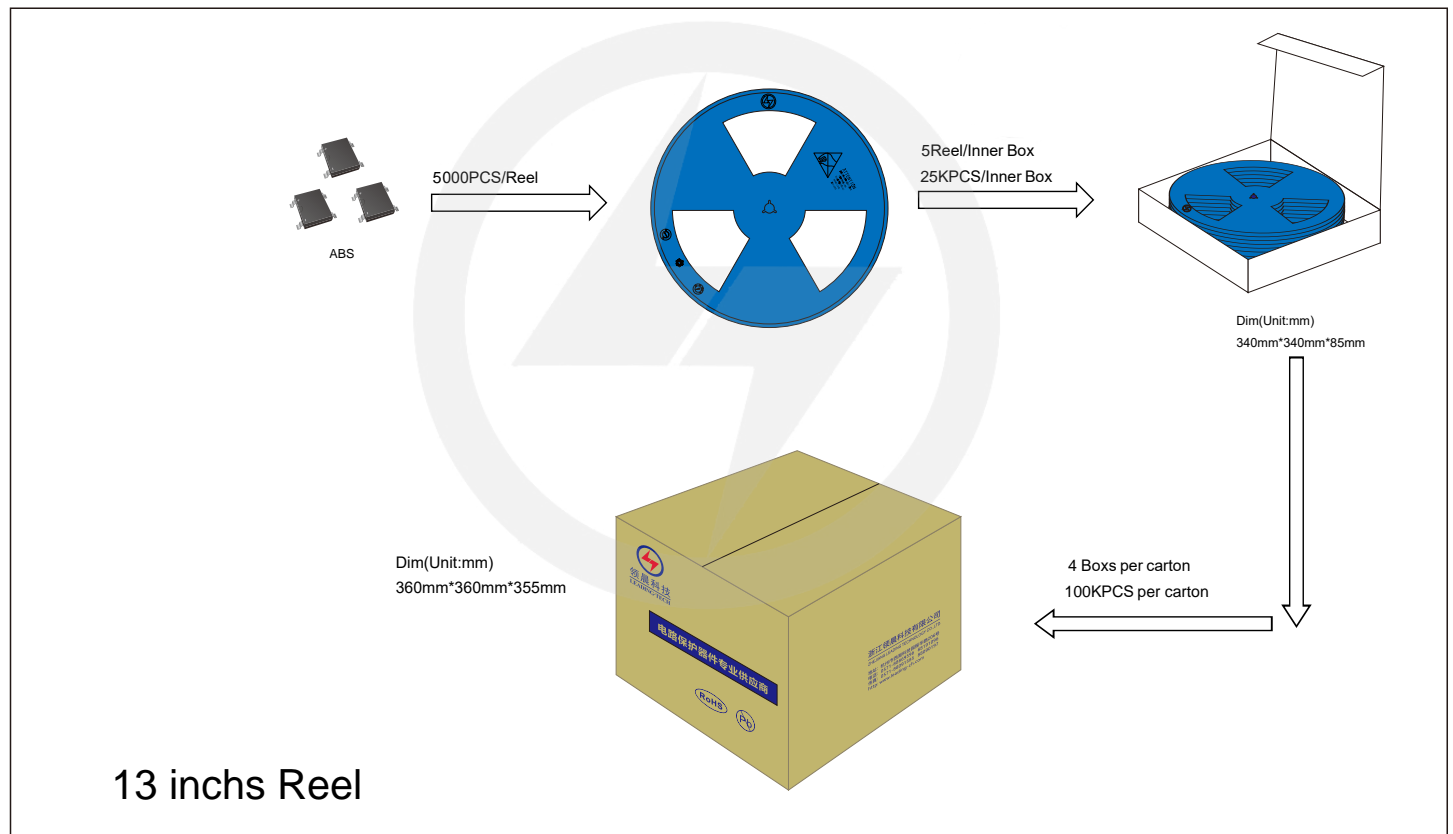



Recommended Soldering Conditions

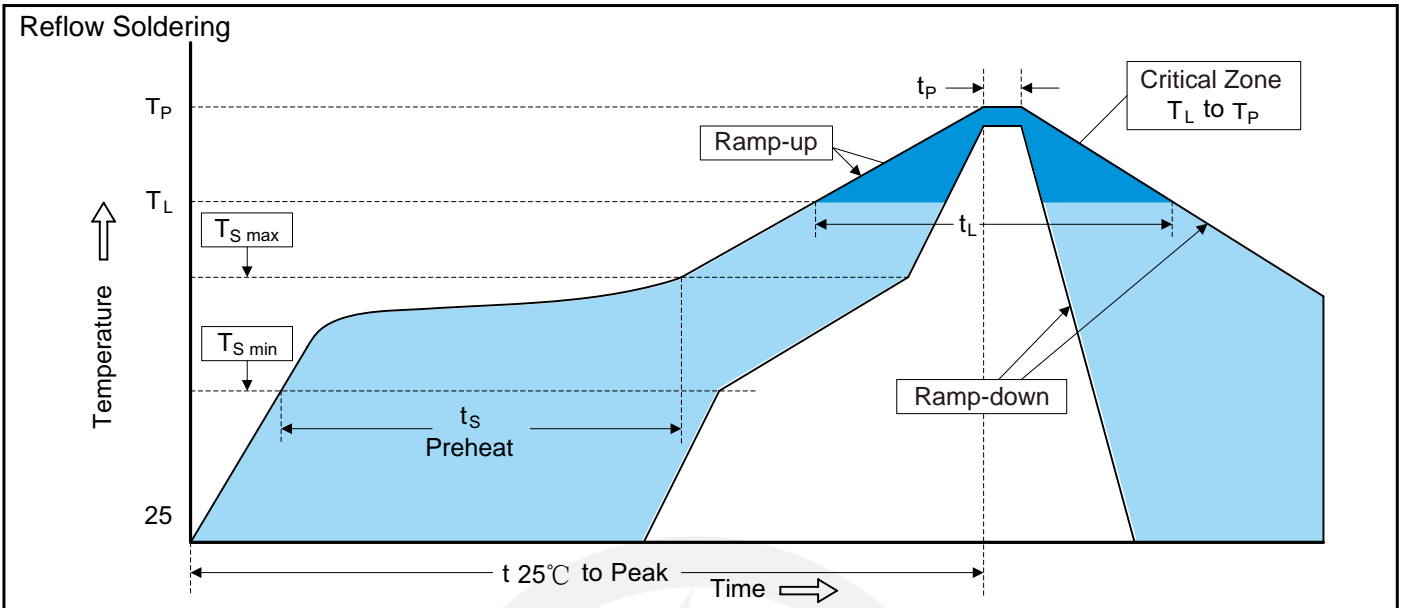

Recommended Conditions

Profile Feature	Pb-Free Assembly
Average ramp-up rate (T _L to T _P)	3°C/second max.
Preheat	
-Temperature Min (T _{S min})	150°C
-Temperature Max (T _{S max})	200°C
-Time (min to max) (t _s)	60-180 seconds
T _{S max} to T _L	
-Ramp-up Rate	3°C/second max.
Time maintained above:	
-Temperature (T _L)	217°C
-Time (t _L)	60-150 seconds
Peak Temperature (T _P)	260°C
Time within 5°C of actual Peak Temperature (t _p)	20-40 seconds
Ramp-down Rate	6°C/second max.
Time 25°C to Peak Temperature	8 minutes max.

Important Notice and Disclaimer

Leading-Tech reserves the right to make changes to this document and its products and specifications at any time without notice.

Customers should obtain and confirm the latest product information and specifications before final design, purchase or use.

Leading-Tech makes no warranty, representation or guarantee regarding the suitability of its products for any particular purpose, not does Leading-Tech assume any liability for application assistance or customer product design.

Leading-Tech does not warrant or accept any liability with products which are purchase or used for any unintended or unauthorized application.

No license is granted by implication or otherwise under any intellectual property rights of Leading-Tech.

Leading-Tech products are not authorized for use as critical components in life support devices or systems without express written approval of Leading-tech.

Version Update Information

Series NO.	Enactment/Revision Date	Effective Date	Version	Revision Content	Revision Reason	Revision Person	Note
01	2025.07.07	2025.07.07	3.0	New file	/	Ding	