

## Transistor (NPN)

### Features

- Ideally suited for automatic insertion
- For Switching and AF Amplifier Applications
- Lead free in comply with EU RoHS 2011/65/EU directives

### Mechanical Data

- Case: SOT-23
- Approx. Weight: 8.1mg

### Ordering Information

Part Number	Marking	Shipping	Reel
LT846B-TR3	1B	3000PCS Tape&Reel	7 inches
LT846B-TR12	1B	12000PCS Tape&Reel	13 inches

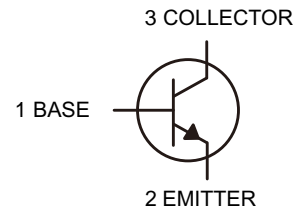
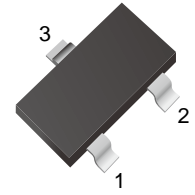

### Limiting Values (Absolute Maximum Ratings)

Symbol	Parameter	Value	Unit
$V_{CB0}$	Collector-Base Voltage	80	V
$V_{CEO}$	Collector-Emitter Voltage	65	V
$V_{EBO}$	Emitter-Base Voltage	6	V
$I_C$	Collector Current	100	mA
$P_C$	Total Device Dissipation	200	mW
$R_{\theta JA}$	Thermal Resistance From Junction To Ambient	625	°C/W
$T_J$	Junction Temperature	150	°C
$T_{STG}$	Storage Temperature	-55~+150	°C

### Electrical characteristics ( $T_a=25$ unless otherwise specified )

Parameter	Symbol	Test condition	Min	Typ	Max	Unit
Collector-base breakdown voltage	$V_{(BR)CB0}$	$I_C=10\mu A, I_E=0$	80			V
Collector-emitter breakdown voltage	$V_{(BR)CEO}$	$I_C=10mA, I_B=0$	65			V
Emitter-base breakdown voltage	$V_{(BR)EBO}$	$I_E=10\mu A, I_C=0$	6			V
Collector cut-off current	$I_{CB0}$	$V_{CB}=70V, I_E=0$			0.1	$\mu A$
Emitter cut-off current	$I_{EBO}$	$V_{EB}=5V, I_C=2mA$			0.1	$\mu A$
DC current gain	$h_{FE}$	$V_{CE}=5V, I_C=2mA$	200		450	
Collector-emitter saturation voltage	$V_{CE(sat)}$	$I_C=100mA, I_B=5mA$			0.5	V
Base-emitter saturation voltage	$V_{BE(sat)}$	$I_C=100mA, I_B=5mA$			1.1	V
Transition frequency	$f_T$	$V_{CE}=5V, I_C=10mA, f=100MHz$	100			MHz
Collector output capacitance	$C_{ob}$	$V_{CB}=10V, f=1MHz$			4.5	pF



Characteristics Curves

Fig.1 Static Characteristic

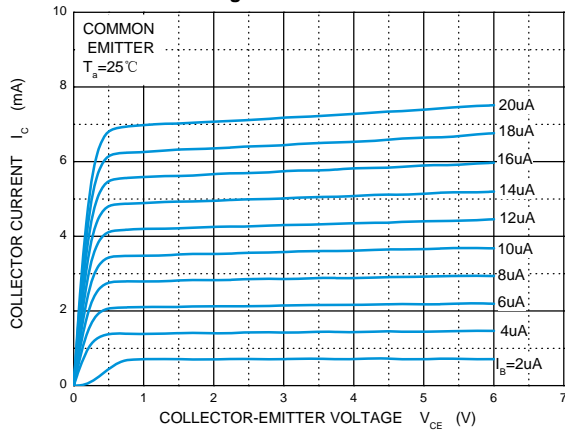

Fig.2  $h_{FE}$  vs  $I_c$

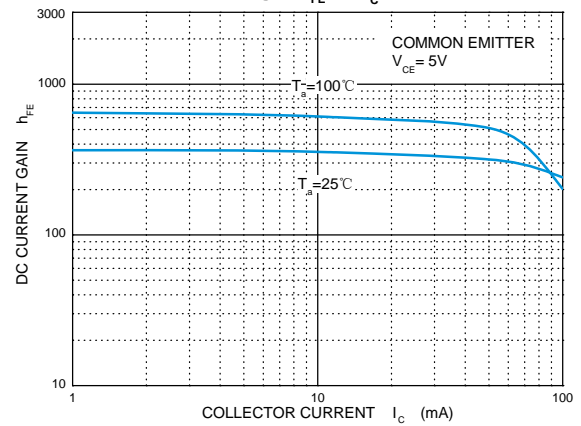

Fig.3  $V_{BEsat}$  vs  $I_c$

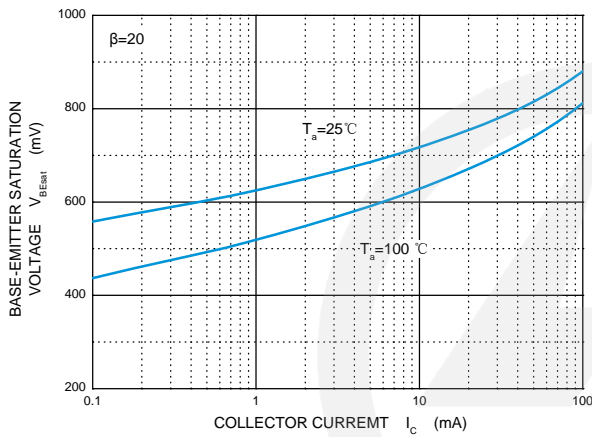

Fig.4  $V_{CEsat}$  vs  $I_c$

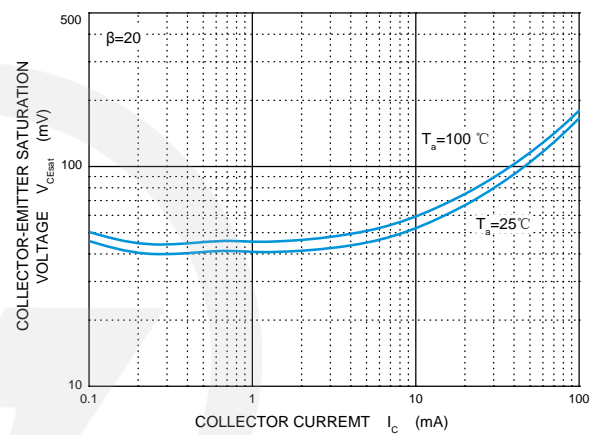

Fig.5  $I_c$  vs  $V_{BE}$

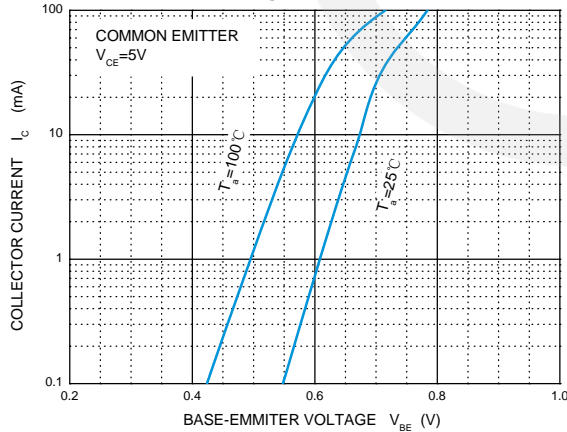

Fig.6  $f_T$  vs  $I_c$

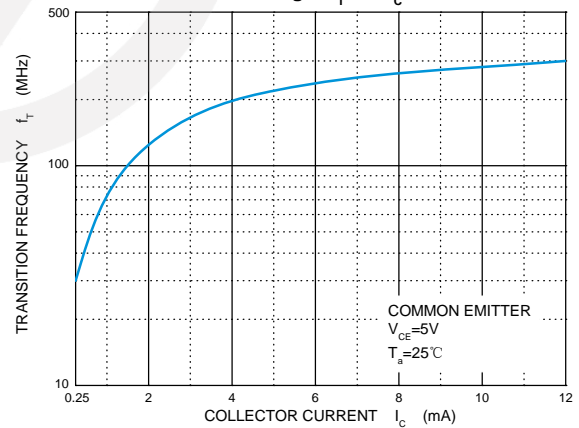

Fig.7  $C_{ob}/C_{ib}$  vs  $V_{CB}/V_{EB}$

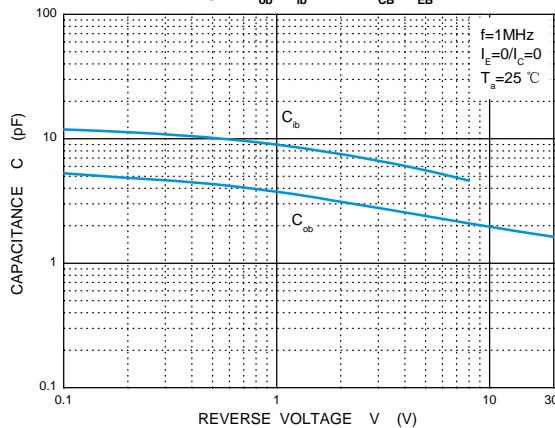
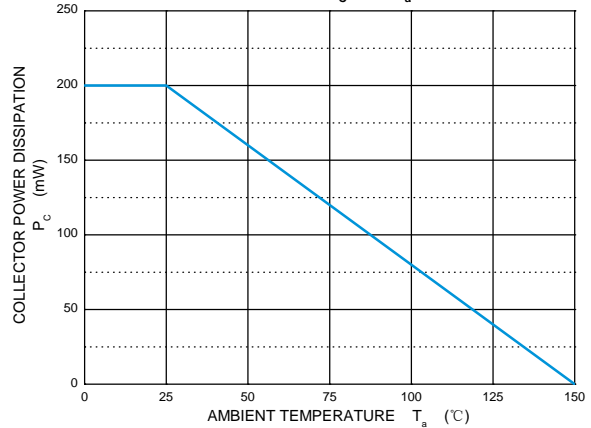

Fig.8  $P_C$  vs  $T_a$





## SOT-23 Package Outline

Unit: mm

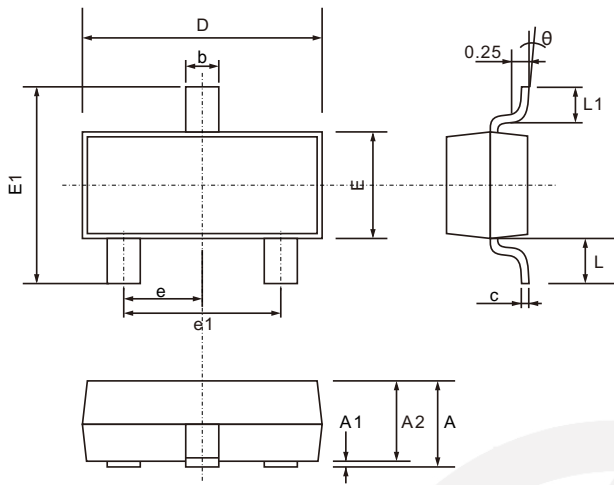

SYMBOL	DIMENSIONS	
	MIN.	MAX.
A	0.900	1.200
A1	0.000	0.100
A2	0.900	1.050
b	0.300	0.500
c	0.080	0.200
D	2.700	3.100
E	1.200	1.400
E1	2.200	2.600
e	0.950 TYP.	
e1	1.750	2.050
L	0.550 TYP.	
L1	0.300	0.500
$\theta$	0°	8°

## SOT-23 Suggested Pad Layout

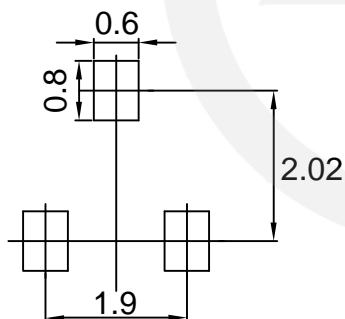

**Note:**

1. Controlling dimension: in millimeters.
2. General tolerance:  $\pm 0.05\text{mm}$
3. The pad layout is for reference purpose only.

**Carrier Tape Dimensions**

Unit : mm

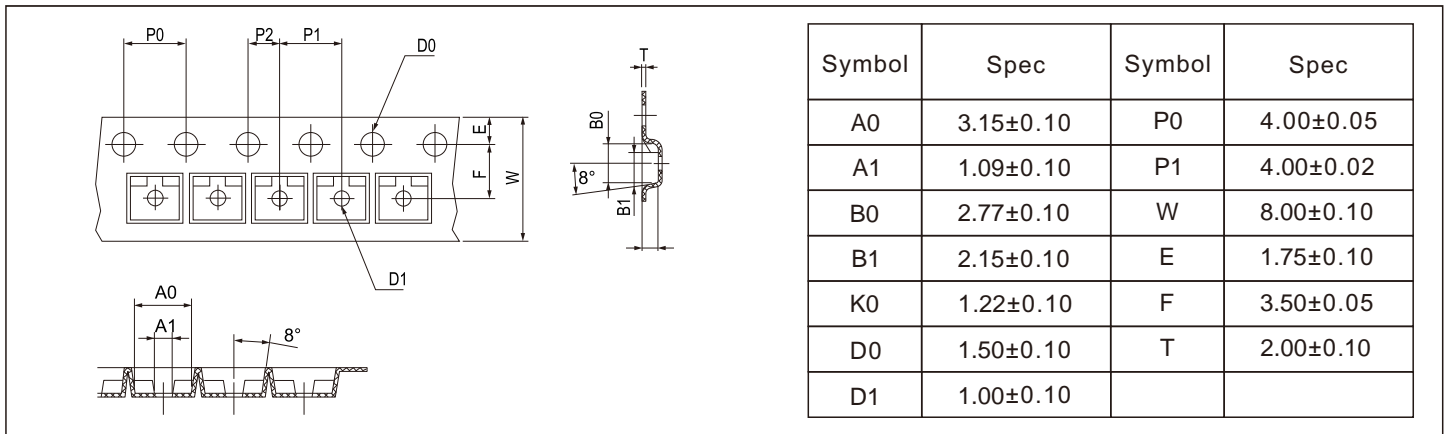

**Reel Dimensions**

Unit : mm

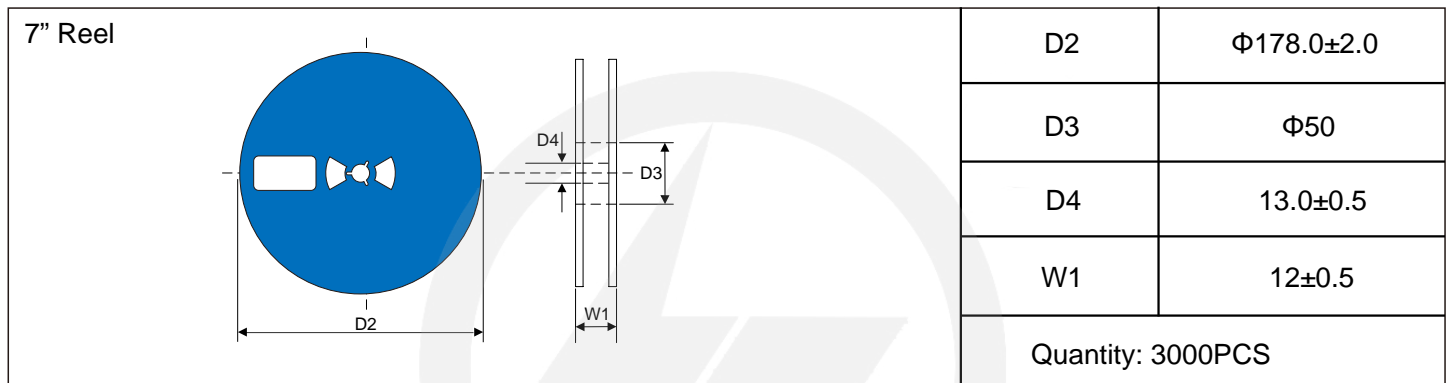

**Reel Dimensions**

Unit : mm

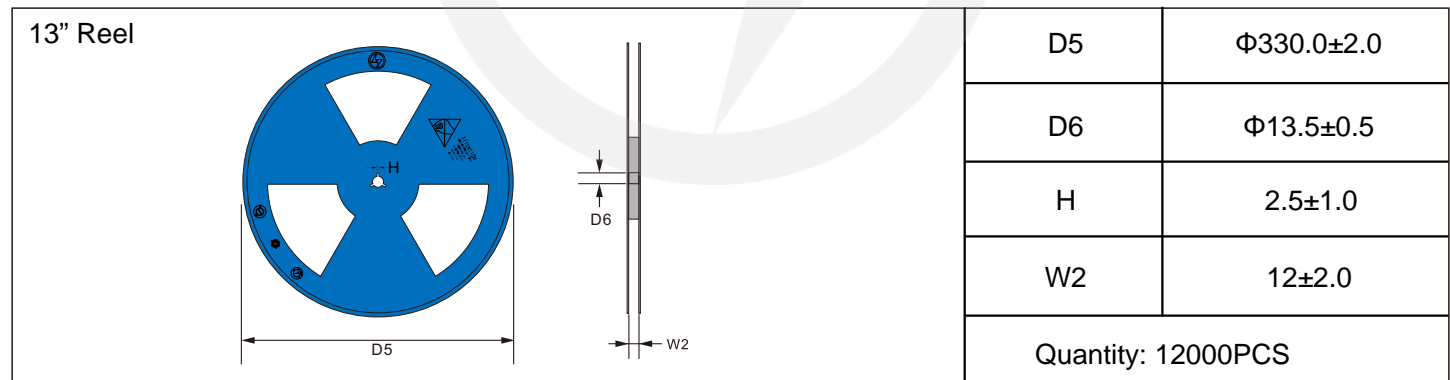

**Packaging**

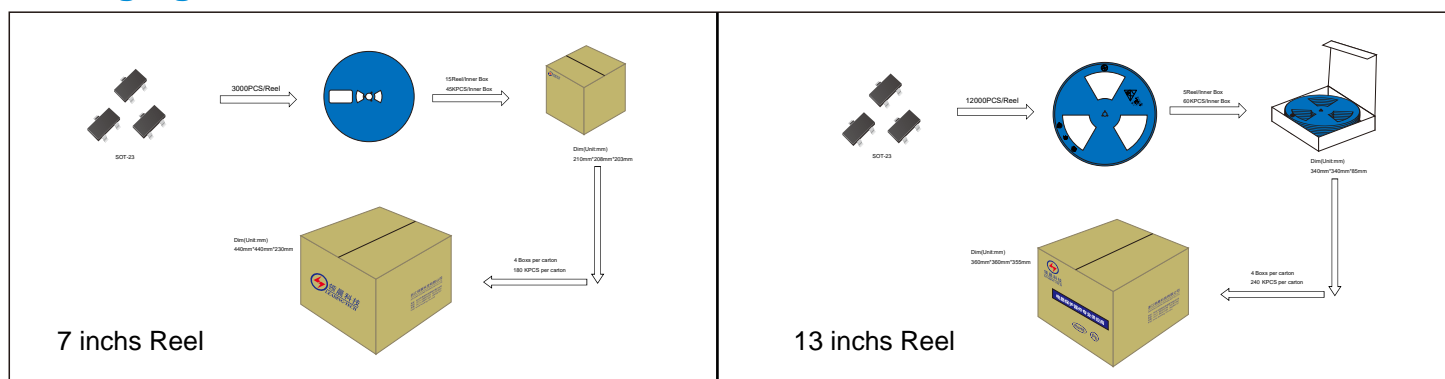



Recommended Soldering Conditions



Recommended Conditions

Profile Feature	Pb-Free Assembly
Average ramp-up rate (T <sub>L</sub> to T <sub>P</sub> )	3°C/second max.
Preheat	
-Temperature Min (T <sub>S min</sub> )	150°C
-Temperature Max (T <sub>S max</sub> )	200°C
-Time (min to max) (t <sub>s</sub> )	60-180 seconds
T <sub>S max</sub> to T <sub>L</sub>	
-Ramp-up Rate	3°C/second max.
Time maintained above:	
-Temperature (T <sub>L</sub> )	217°C
-Time (t <sub>L</sub> )	60-150 seconds
Peak Temperature (T <sub>P</sub> )	260°C
Time within 5°C of actual Peak Temperature (t <sub>p</sub> )	20-40 seconds
Ramp-down Rate	6°C/second max.
Time 25°C to Peak Temperature	8 minutes max.

## Important Notice and Disclaimer

Leading-Tech reserves the right to make changes to this document and its products and specifications at any time without notice.

Customers should obtain and confirm the latest product information and specifications before final design, purchase or use.

Leading-Tech makes no warranty, representation or guarantee regarding the suitability of its products for any particular purpose, not does Leading-Tech assume any liability for application assistance or customer product design.

Leading-Tech does not warrant or accept any liability with products which are purchase or used for any unintended or unauthorized application.

No license is granted by implication or otherwise under any intellectual property rights of Leading-Tech.

Leading-Tech products are not authorized for use as critical components in life support devices or systems without express written approval of Leading-Tech.

## Version Update Information

Series NO.	Enactment/Revision Date	Effective Date	Version	Revision Content	Revision Reason	Revision Person	Note
01	2024.08.18	2024.08.18	3.0	New file	/	Ding	
02	2025.06.12	2025.06.12	3.1	Update packaging information	/	Ding	
03	2026.03.06	2026.03.06	3.2	Package outline E1(max)=2.6mm	/	Ding	