

Fast Switching Diode

Features

- Small Package
- Low Reverse Current
- Fast Switching Speed
- Surface Mount Package Ideally Suited for Automatic Insertion
- Lead free in comply with EU RoHS 2011/65/EU directives

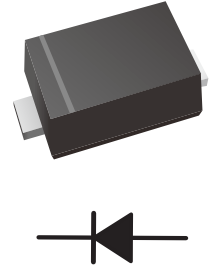

Mechanical Data

- Package: SOD-523
- Polarity: Color band denotes cathode end

Ordering Information

Part Number	Marking	Shipping	Reel
LT5L4148-TR3	T4	3000PCS Tape&Reel	7 inches
LT5L4148-TR8	T4	8000PCS Tape&Reel	7 inches

Maximum Ratings at 25°C

Parameter	Symbols	LT5L4148	Units
Non-Repetitive Peak Reverse Voltage	V_{RM}	100	V
Reverse Voltage	V_R	75	V
Peak Repetitive Reverse Voltage	V_{RRM}		V
Working Peak Reverse Voltage	V_{RWM}		V
RMS Reverse Voltage	$V_{R(RMS)}$	53	V
Average Rectified Output Current	I_o	150	mA
Non-repetitive Peak Forward Surge Current@t= 8.3ms	I_{FSM}	0.8	A
Power Dissipation	P_D	150	mW
Junction Temperature	T_j	150	°C
Storage Temperature	T_{stg}	-55 ~ +150	°C

Electrical Characteristics (Ta=25°C unless otherwise specified)

Parameter	Symbols	Test conditions	Min	Typ	Max	Units
Reverse voltage	$V_{(BR)}$	$I_R = 1\mu A$	75			V
Reverse current	I_R	$V_R = 75V$			1	μA
		$V_R = 20V$			25	nA
Forward voltage	V_F	$I_F = 1\text{ mA}$			0.715	V
		$I_F = 10\text{ mA}$			0.855	V
		$I_F = 50\text{ mA}$			1	V
		$I_F = 150\text{ mA}$			1.25	V
Total capacitance	C_{tot}	$V_R = 0V, f = 1\text{MHz}$			2	pF
Reverse recovery time	t_{rr}	$I_F = I_R = 10\text{mA}, I_{rr} = 0.1 * I_R, R_L = 100\Omega$			4	ns

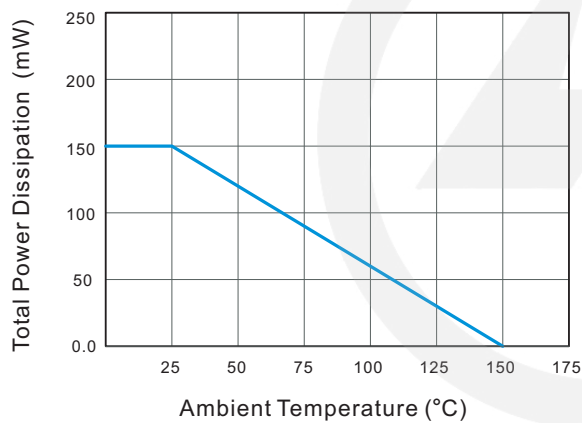
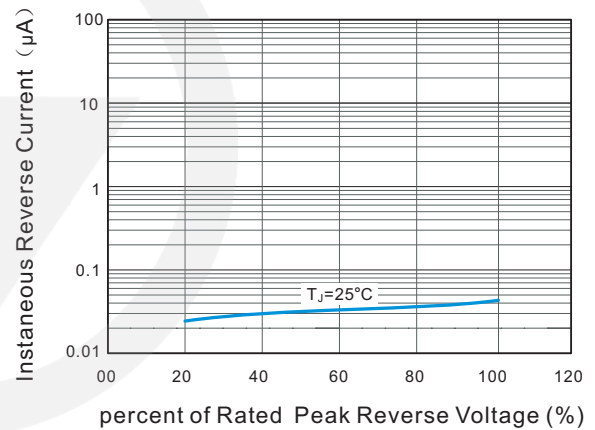
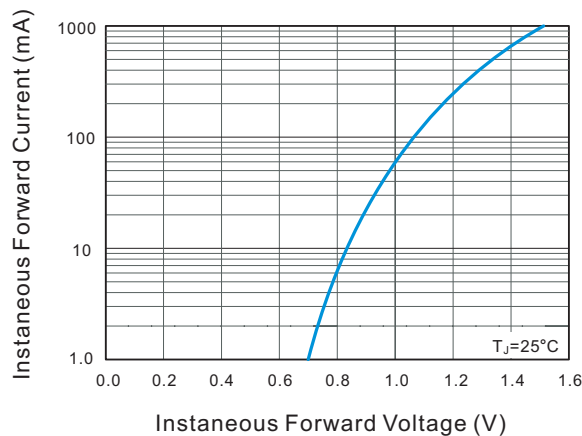
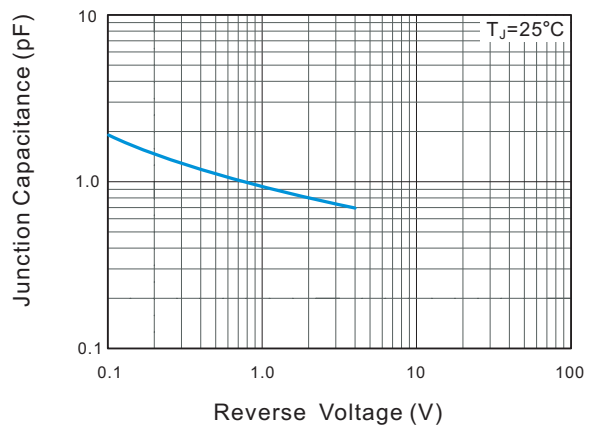
Characteristics Curve
Fig.1 Power Derating Curve

Fig.2 Typical Reverse Characteristics

Fig.3 Typical Instantaneous Forward Characteristics

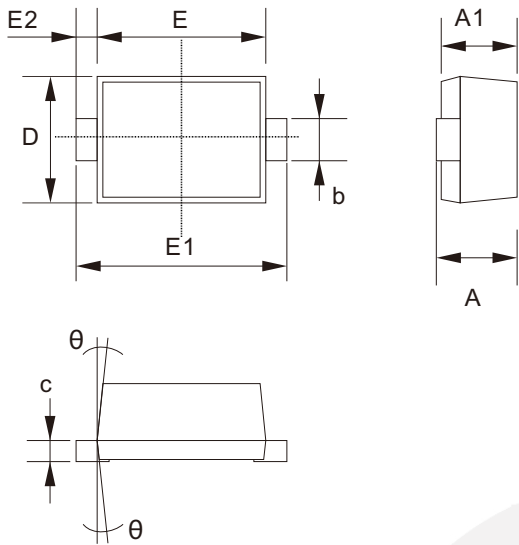
Fig.4 Typical Junction Capacitance

SOD-523 Package Outline

Unit: mm



SYMBOL	DIMENSIONS	
	MIN.	MAX.
A	0.500	0.770
A1	0.500	0.700
b	0.250	0.380
c	0.070	0.200
D	0.700	0.900
E	1.100	1.300
E1	1.500	1.700
E2	0.200 REF	
θ	7° REF	

SOD-523 Suggested Pad Layout

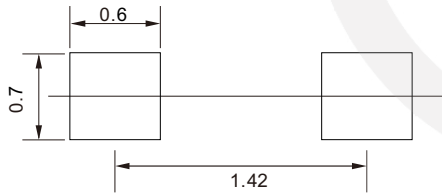

- Note:
1. Controlling dimension: in millimeters.
 2. General tolerance: ± 0.05 mm.
 3. The pad layout is for reference purposes only.

Carrier Tape Dimensions

Unit : mm

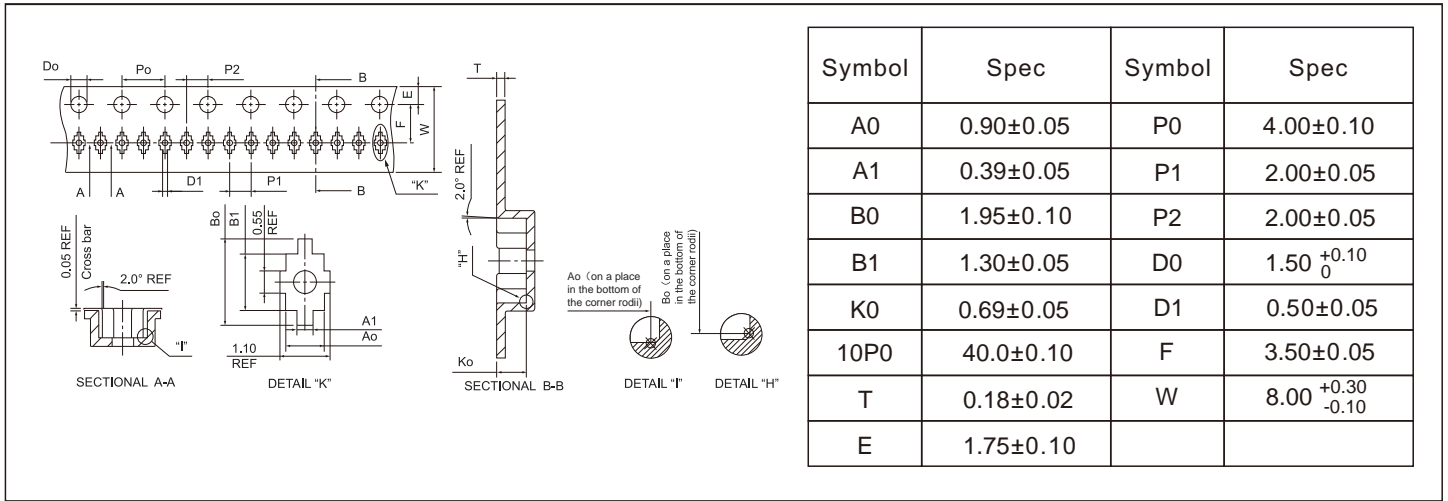

Reel Dimensions

Unit : mm

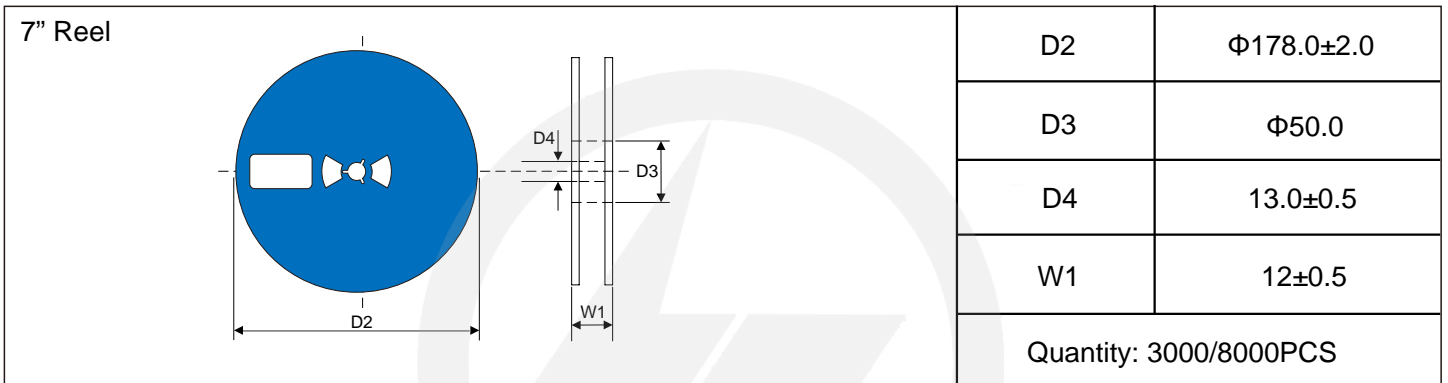

Packaging

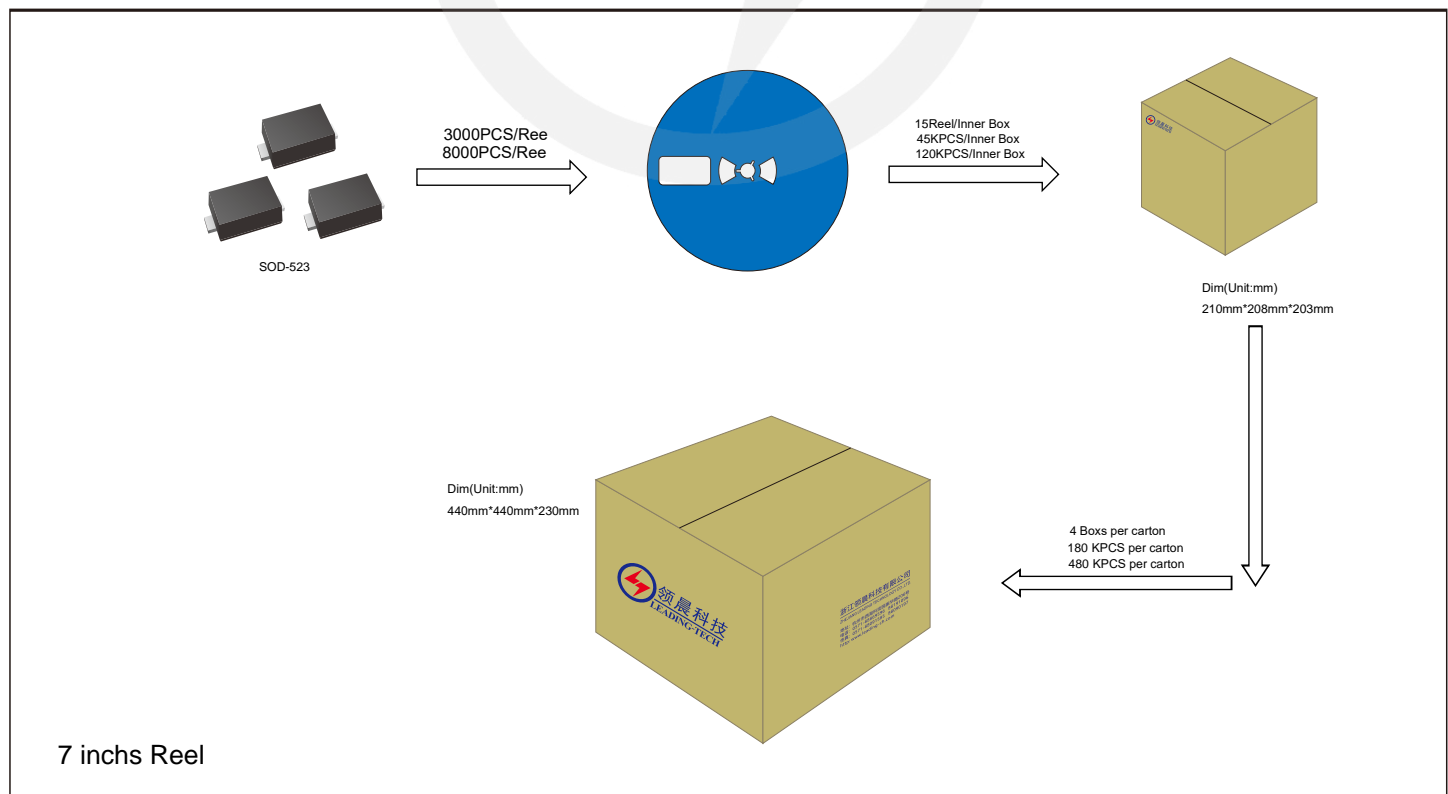



Recommended Soldering Conditions



Recommended Conditions

Profile Feature	Pb-Free Assembly
Average ramp-up rate (T _L to T _P)	3°C/second max.
Preheat	
-Temperature Min (T _{S min})	150°C
-Temperature Max (T _{S max})	200°C
-Time (min to max) (t _s)	60-180 seconds
T _{S max} to T _L	
-Ramp-up Rate	3°C/second max.
Time maintained above:	
-Temperature (T _L)	217°C
-Time (t _L)	60-150 seconds
Peak Temperature (T _P)	260°C
Time within 5°C of actual Peak Temperature (t _p)	20-40 seconds
Ramp-down Rate	6°C/second max.
Time 25°C to Peak Temperature	8 minutes max.

Important Notice and Disclaimer

Leading-Tech reserves the right to make changes to this document and its products and specifications at any time without notice.

Customers should obtain and confirm the latest product information and specifications before final design, purchase or use.

Leading-Tech makes no warranty, representation or guarantee regarding the suitability of its products for any particular purpose, not does Leading-Tech assume any liability for application assistance or customer product design.

Leading-tech does not warrant or accept any liability with products which are purchase or used for any unintended or unauthorized application.

No license is granted by implication or otherwise under any intellectual property rights of Leading-Tech.

Leading-Tech products are not authorized for use as critical components in life support devices or systems without express written approval of Leading-tech.

Version Update Information

Series NO.	Enactment/Revision Date	Effective Date	Version	Revision content	Revision Reason	Revision Person	Note
01	2024.3.14	2024.3.14	3.0	New File	/	Ding	
02	2025.5.13	2025.5.13	3.1	Modify the number of reels	/	Ding	