

Zener Diodes

Features

- Planar Die Construction
- 500mW Power Dissipation on Ceramic PCB
- General Purpose, Medium Current
- Ideally Suited for Automated Assembly Processes
- Available in Lead Free Version
- Lead free in comply with EU RoHS 2011/65/EU directives

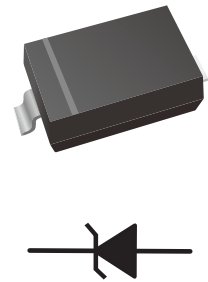

Mechanical Data

- Case: SOD-123
- Terminals: Solderable per MIL-STD-750, Method 2026
- Polarity: Color band denotes cathode end

Ordering information

Part Number	Shipping	Reel
LT52CxxW-TR3	3000PCS Tape&Reel	7inchs
LT52CxxW-TR12	12000PCS Tape&Reel	13inchs

Maximum Ratings ($T_a=25$ unless otherwise Specified)

Characteristic	Symbol	Value	Unit
Forward Voltage (Note 2) @ $I_F = 10\text{mA}$	V_F	0.9	V
Power Dissipation(Note 1)	P_D	500	mW
Thermal Resistance from Junction to Ambient(Note 1)	$R_{\theta JA}$	250	$^{\circ}\text{C/W}$
Operation Junction and Storage Temperature Range	T_J, T_{STG}	-55~+150	$^{\circ}\text{C}$

Electrical Characteristics (Ta=25 unless otherwise Specified)

Type Number	Marking	Zener Voltage Range (Note 2)				Maximum Zener Impedance (Note 3)			Maximum Reverse Current (Note 2)		Typical Temperature Coefficient @I _{ZTC} mV/°C		Test Current I _{ZTC} mA
		V _Z @I _{ZT}			I _{ZT}	Z _{ZT} @I _{ZT}	Z _{ZK} @I _{ZK}	I _{ZK}	I _R	V _R	Min	Max	
		Nom(V)	Min(V)	Max(V)	mA	Ω		mA	uA	V			
LT52C2V7W	W1	2.7	2.5	2.9	5	100	600	1.0	20	1.0	-3.5	0	5
LT52C3V0W	W2	3.0	2.8	3.2	5	95	600	1.0	10	1.0	-3.5	0	5
LT52C3V3W	W3	3.3	3.1	3.5	5	95	600	1.0	5	1.0	-3.5	0	5
LT52C3V6W	W4	3.6	3.4	3.8	5	90	600	1.0	5	1.0	-3.5	0	5
LT52C3V9W	W5	3.9	3.7	4.1	5	90	600	1.0	3	1.0	-3.5	0	5
LT52C4V3W	W6	4.3	4.0	4.6	5	90	600	1.0	3	1.0	-3.5	0	5
LT52C4V7W	W7	4.7	4.4	5.0	5	80	500	1.0	3	2.0	-3.5	0.2	5
LT52C5V1W	W8	5.1	4.8	5.4	5	60	480	1.0	2	2.0	-2.7	1.2	5
LT52C5V6W	W9	5.6	5.2	6.0	5	40	400	1.0	1	2.0	-2.0	2.5	5
LT52C6V2W	WA	6.2	5.8	6.6	5	10	150	1.0	3	4.0	0.4	3.7	5
LT52C6V8W	WB	6.8	6.4	7.2	5	15	80	1.0	2	4.0	1.2	4.5	5
LT52C7V5W	WC	7.5	7.0	7.9	5	15	80	1.0	1	5.0	2.5	5.3	5
LT52C8V2W	WD	8.2	7.7	8.7	5	15	80	1.0	0.7	5.0	3.2	6.2	5
LT52C9V1W	WE	9.1	8.5	9.6	5	15	100	1.0	0.5	6.0	3.8	7.0	5
LT52C10W	WF	10	9.4	10.6	5	20	150	1.0	0.2	7.0	4.5	8.0	5
LT52C11W	WG	11	10.4	11.6	5	20	150	1.0	0.1	8.0	5.4	9.0	5
LT52C12W	WH	12	11.4	12.7	5	25	150	1.0	0.1	8.0	6.0	10.0	5
LT52C13W	WI	13	12.4	14.1	5	30	170	1.0	0.1	8.0	7.0	11.0	5
LT52C15W	WJ	15	13.8	15.6	5	30	200	1.0	0.1	10.5	9.2	13.0	5
LT52C16W	WK	16	15.3	17.1	5	40	200	1.0	0.1	11.2	10.4	14.0	5
LT52C18W	WL	18	16.8	19.1	5	45	225	1.0	0.1	12.6	12.4	16.0	5
LT52C20W	WM	20	18.8	21.2	5	55	225	1.0	0.1	14.0	14.4	18.0	5
LT52C22W	WN	22	20.8	23.3	5	55	250	1.0	0.1	15.4	16.4	20.0	5
LT52C24W	WO	24	22.8	25.6	5	70	250	1.0	0.1	16.8	18.4	22.0	5
LT52C27W	WP	27	25.1	28.9	2	80	300	0.5	0.1	18.9	21.4	25.3	2
LT52C30W	WQ	30	28.0	32.0	2	80	300	0.5	0.1	21.0	24.4	29.4	2
LT52C33W	WR	33	31.0	35.0	2	80	325	0.5	0.1	23.1	27.4	33.4	2
LT52C36W	WS	36	34.0	38.0	2	90	350	0.5	0.1	25.2	30.4	37.4	2

Notes: 1. Device mounted on ceramic PCB: 7.6mm x 9.4mm x 0.87mm with pad areas 25mm²

2. Short duration test pulse used to minimize self-heating effect

3. f=1kHz

Electrical Characteristics (Ta=25 unless otherwise Specified)

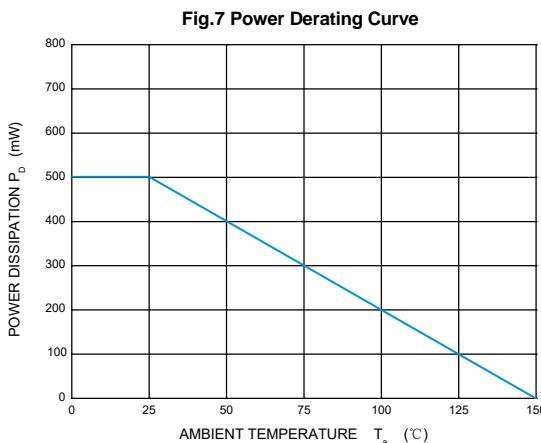
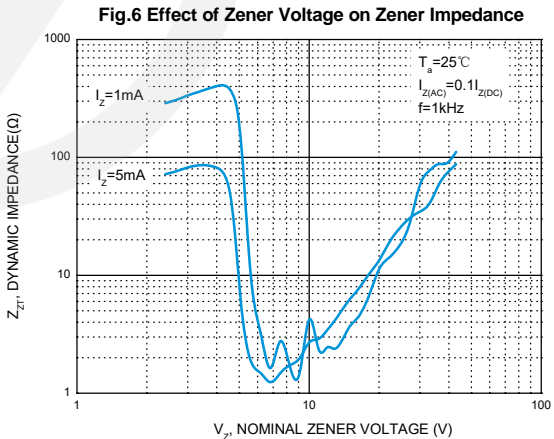
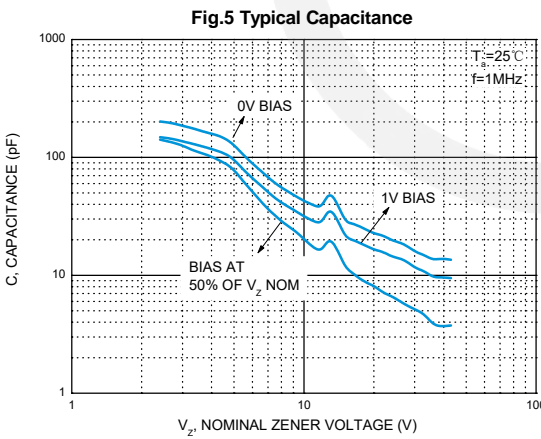
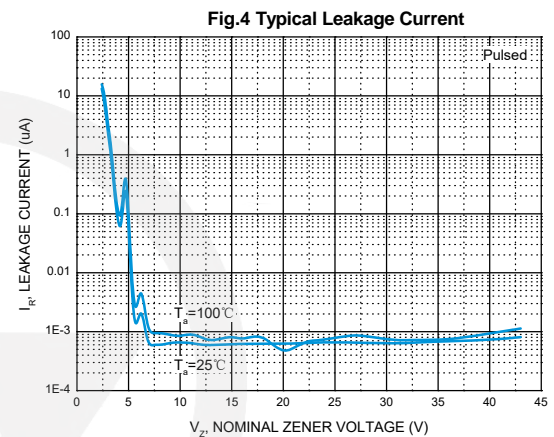
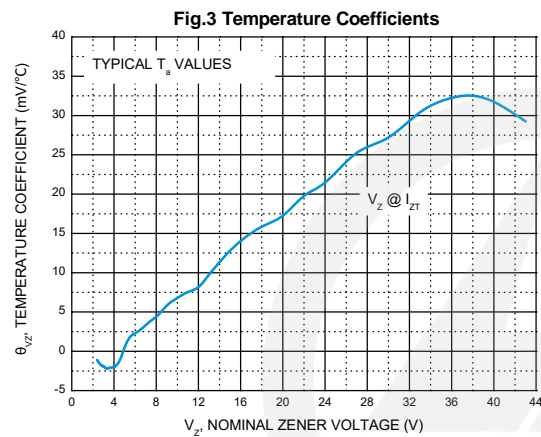
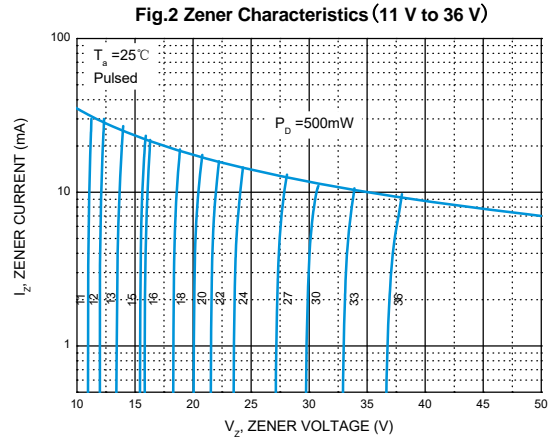
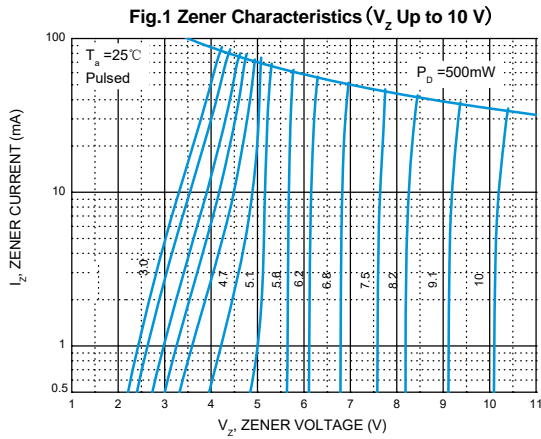

SOD-123 Package Outline

Unit: mm

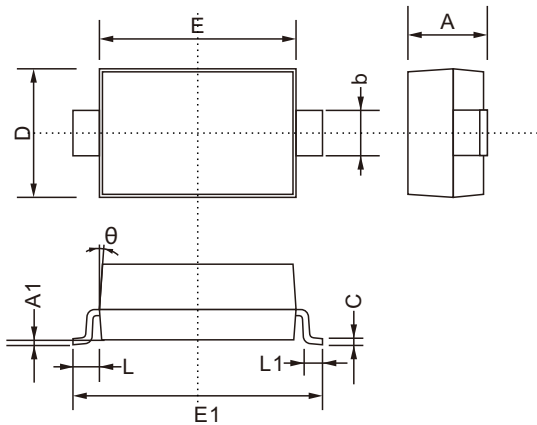

SYMBOL	DIMENSIONS	
	MIN.	MAX.
A	0.900	1.300
A1	0.000	0.200
b	0.450	0.750
C	0.080	0.230
D	1.500	1.800
E	2.500	2.800
E1	3.550	3.900
L1	0.250	0.450
L	0.5REF	
θ	8°	

SOD-123 Suggested Pad Layout

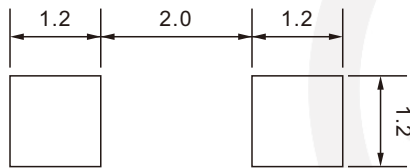

Note:

1. Controlling dimension: in millimeters.
2. General tolerance: $\pm 0.05\text{mm}$
3. The pad layout is for reference purpose only.

Carrier Tape Dimensions

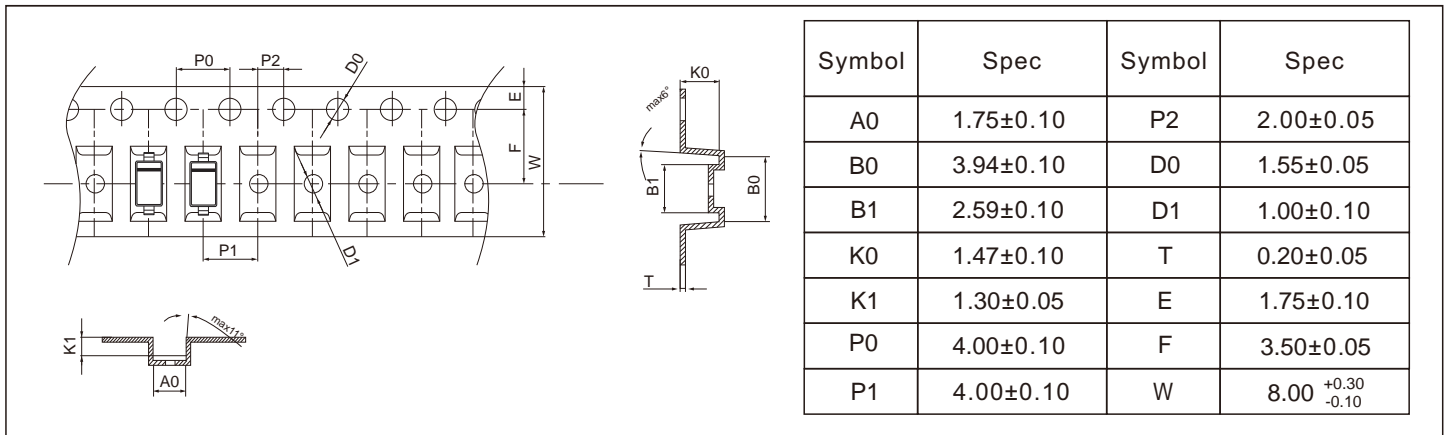

Reel Dimensions

Unit : mm

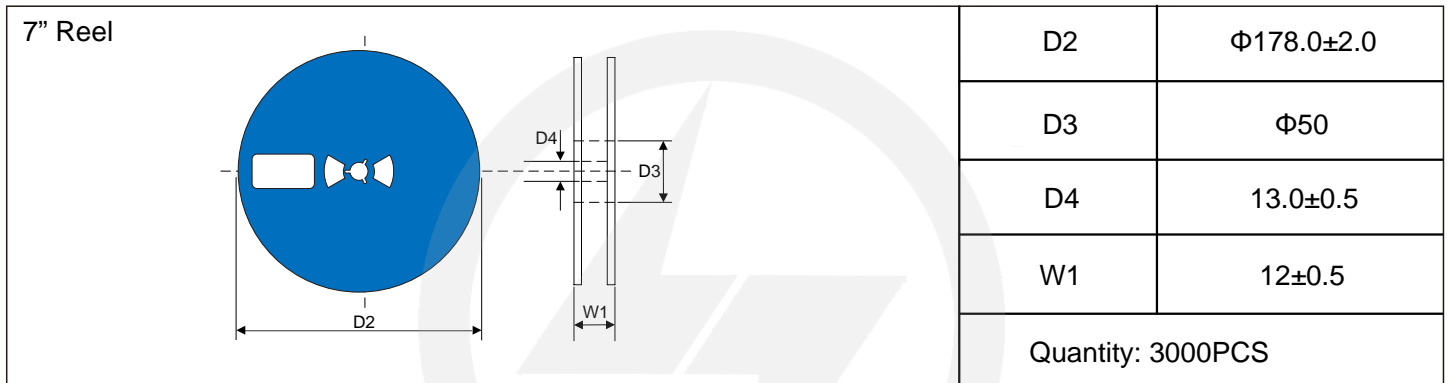

Reel Dimensions

Unit : mm

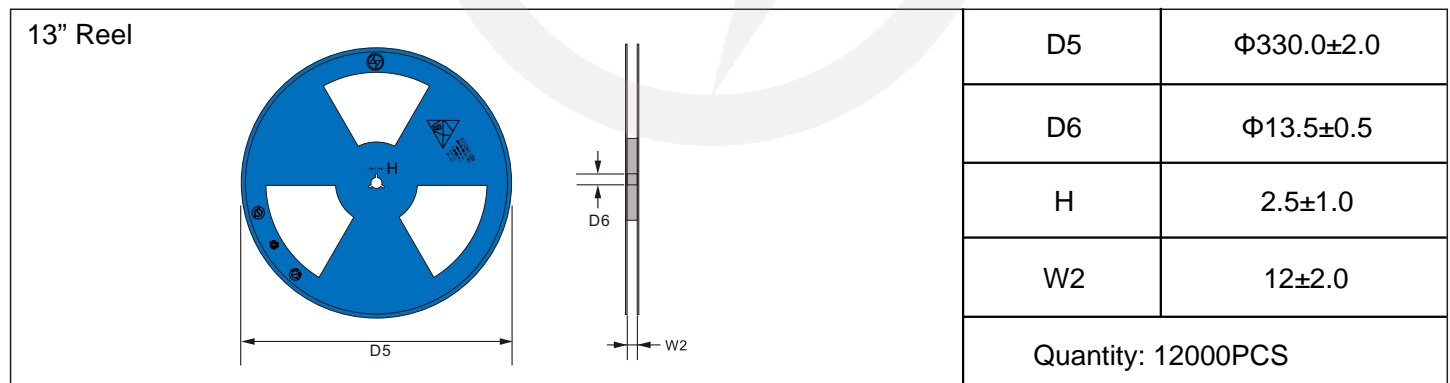

Packaging

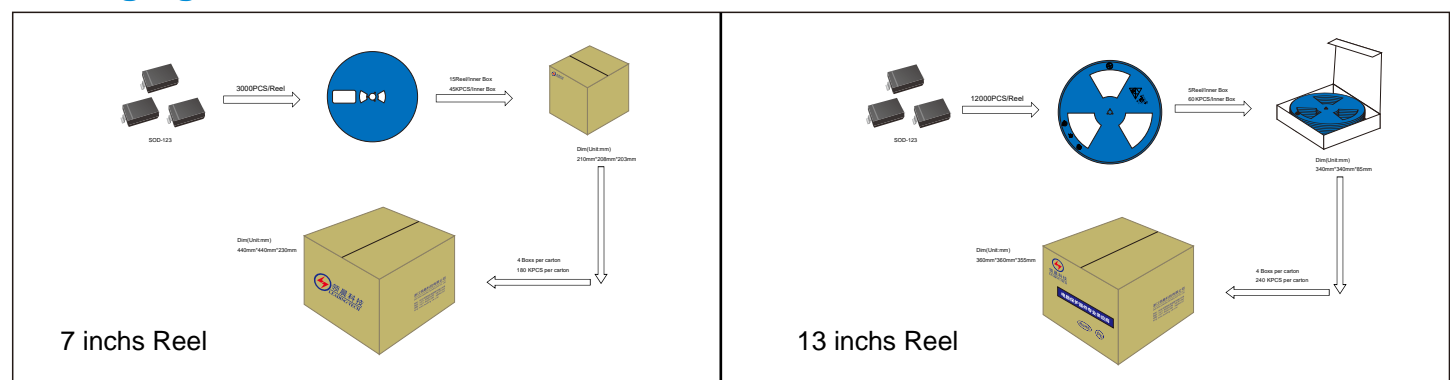



Recommended Soldering Conditions

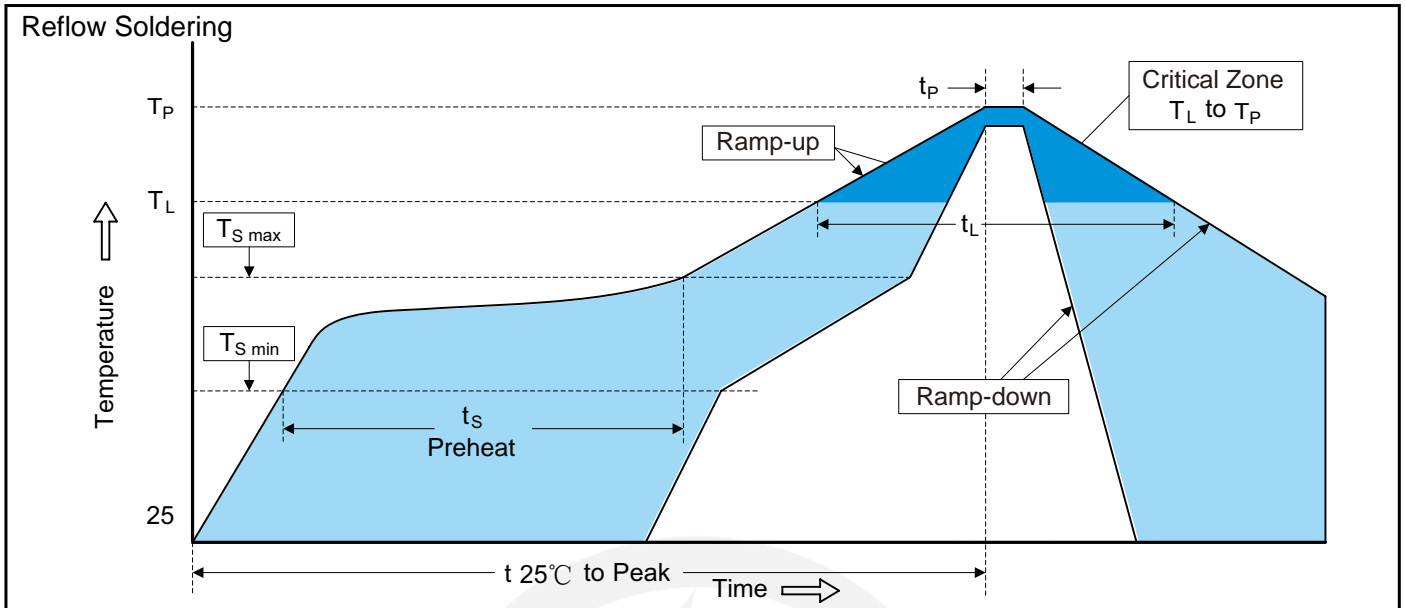

Recommended Conditions

Profile Feature	Pb-Free Assembly
Average ramp-up rate (T _L to T _P)	3°C/second max.
Preheat	
-Temperature Min (T _{S min})	150°C
-Temperature Max (T _{S max})	200°C
-Time (min to max) (t _s)	60-180 seconds
T _{S max} to T _L	
-Ramp-up Rate	3°C/second max.
Time maintained above:	
-Temperature (T _L)	217°C
-Time (t _L)	60-150 seconds
Peak Temperature (T _P)	260°C
Time within 5°C of actual Peak Temperature (t _p)	20-40 seconds
Ramp-down Rate	6°C/second max.
Time 25°C to Peak Temperature	8 minutes max.

Important Notice and Disclaimer

Leading-Tech reverses the right to make changes to this document and its products and specifications at any time without notice.

Customers should obtain and confirm the latest product information and specifications before final design, purchase or use.

Leading-Tech makes no warranty, representation or guarantee regarding the suitability of its products for any particular purpose, not does Leading-Tech assume any liability for application assistance or customer product design.

Leading-tech does not warrant or accept any liability with products which are purchase or used for any unintended or unauthorized application.

No license is granted by implication or otherwise under any intellectual property rights of Leading-Tech.

Leading-Tech products are not authorized for use as critical components in life support devices or systems without express written approval of Leading-tech.

Version Update Information

Series NO.	Enactment/Revision Date	Effective Date	Version	Revision content	Revision Reason	Revision Person	Note
01	2024.4.17	2024.4.17	3.0	New File	/	Ding	
02	2025.06.18	2025.06.18	3.1	Update packaging information	/	Ding	