

Transistor (NPN)

Features

- Low collector-emitter saturation voltage
- High current capability
- Improved device reliability due to reduced heat generation
- Lead free in comply with EU RoHS 2011/65/EU directives

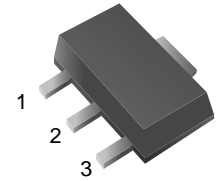

Ordering Information

Part Number	Marking	Shipping	Reel
LT4240W-TR1	ZE	1000PCS Tape&Reel	7 inches
LT4240W-TR3	ZE	3000PCS Tape&Reel	13 inches

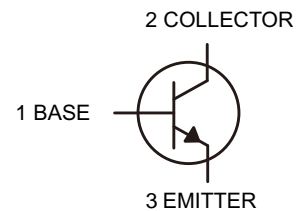

Maximum Ratings (Ta=25°C unless otherwise noted)

Parameter	Symbol	Value	Unit
Collector- Base Voltage	V_{CBO}	40	V
Collector- Emitter Voltage	V_{CEO}	40	V
Emitter- Base Voltage	V_{EBO}	5	V
Collector Current — Continuous	I_C	2	A
Collector Power Dissipation	P_C	500	mW
Thermal Resistance From JunctionTo Ambient	$R_{\theta JA}$	250	°C/W
Operation Junction and Storage Temperature Range	T_J, T_{stg}	-55~ +150	°C

Electrical characteristics (Ta=25 unless otherwise specified)

Parameter	Symbol	Test conditions	Min	Typ	Max	Unit
Collector-base breakdown voltage	$V_{(BR)CBO}$	$I_C = 0.1mA, I_E = 0$	40			V
Collector-emitter breakdown voltage	$V_{(BR)CEO}$	$I_C = 1mA, I_B = 0$	40			V
Emitter-base breakdown voltage	$V_{(BR)EBO}$	$I_E = 0.1mA, I_C = 0$	5			V
Collector cut-off current	I_{CBO}	$V_{CB} = 30V, I_E = 0$			100	nA
Emitter cut-off current	I_{EBO}	$V_{EB} = 4V, I_C = 0$			100	nA
DC current gain	$h_{FE(1)}$	$V_{CE} = 2V, I_C = 100mA$	350			
	$h_{FE(2)}$	$V_{CE} = 2V, I_C = 500mA$	300			
	$h_{FE(3)}$	$V_{CE} = 2V, I_C = 1A$	300			
	$h_{FE(4)}$	$V_{CE} = 2V, I_C = 2A$	150			
Collector-emitter saturation voltage	$V_{CE(sat)}$	$I_C = 100mA, I_B = 1mA$			70	mV
		$I_C = 500mA, I_B = 50mA$			100	mV
		$I_C = 750mA, I_B = 15mA$			180	mV
		$I_C = 1A, I_B = 50mA$			180	mV
		$I_C = 2A, I_B = 200mA$			320	mV
Base-emitter saturation voltage	$V_{BE(sat)}$	$I_C = 2A, I_B = 200mA$			1.1	V
Base-emitter voltage	$V_{BE(ON)}$	$V_{CE} = 2V, I_C = 100mA$			0.75	V
Transition frequency	f_T	$V_{CE} = 10V, I_C = 100mA, f=100MHz$	100			MHz
Collector output capacitance	C_{ob}	$V_{CB} = 10V, I_E = 0, f = 1MHz$			20	pF



Characteristics Curves

Fig.1 h_{FE} vs I_c

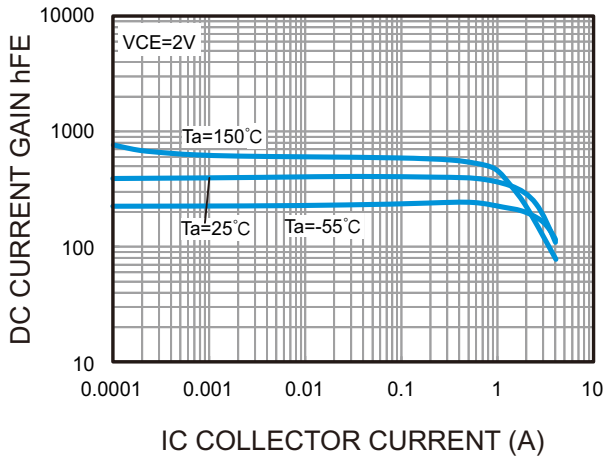

Fig.2 $V_{BE(on)}$ vs I_c

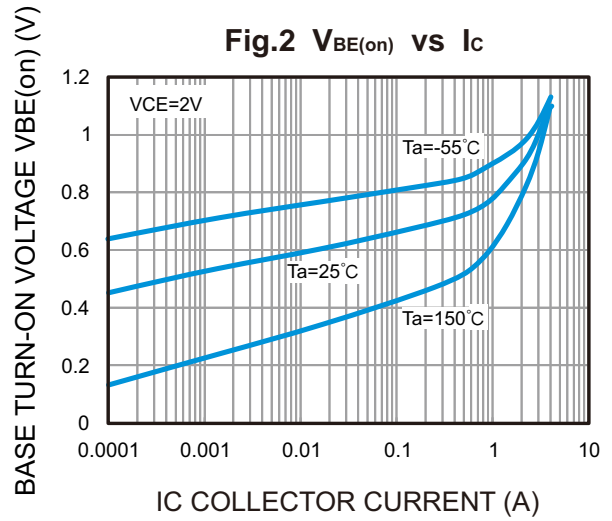

Fig.3 $V_{CE(sat)}$ vs I_c

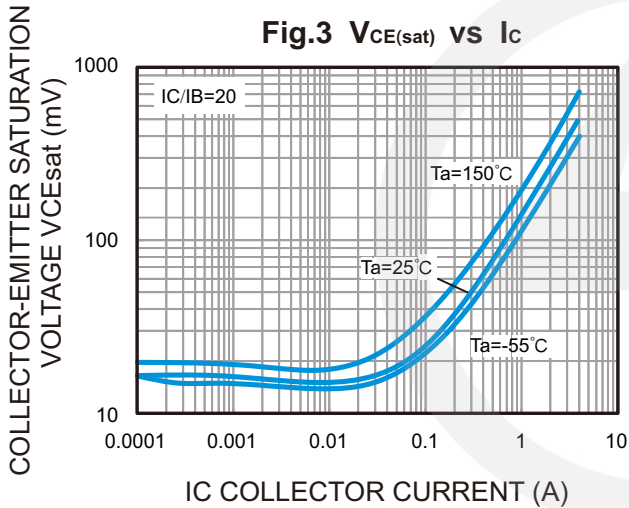

Fig.4 $V_{BE(sat)}$ vs I_c

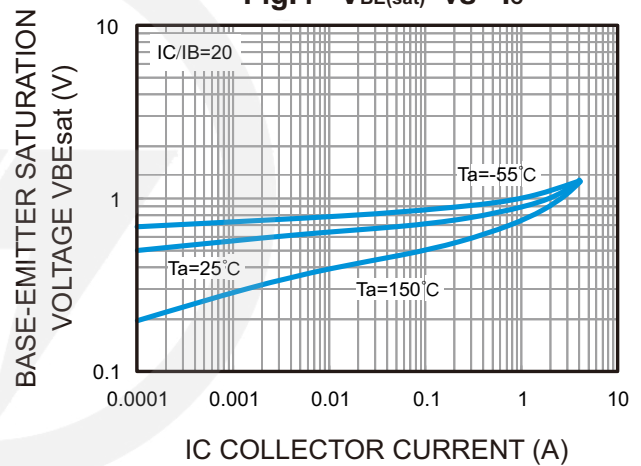

Fig.5 I_c vs V_{CE}

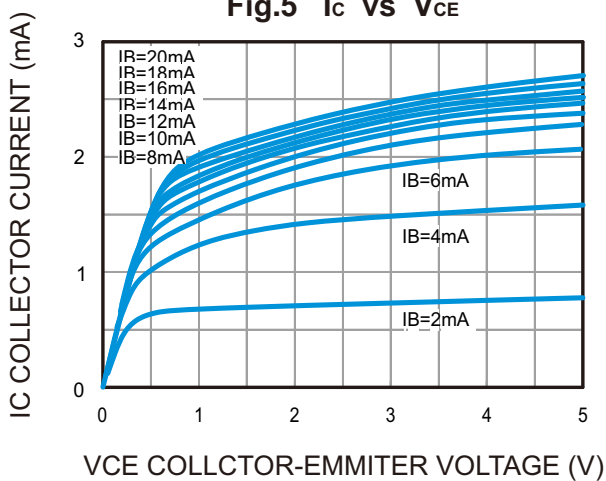
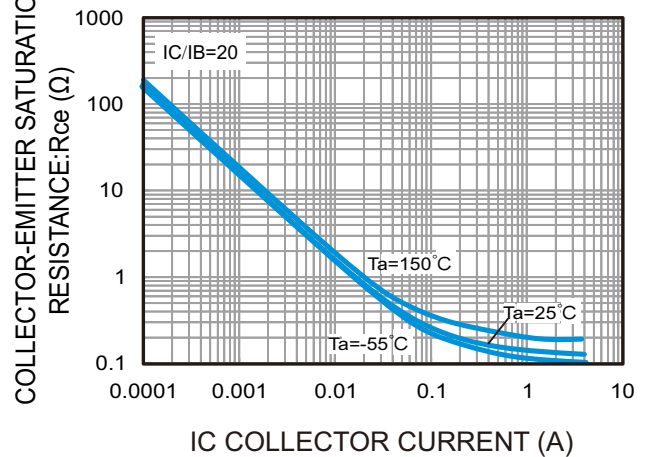
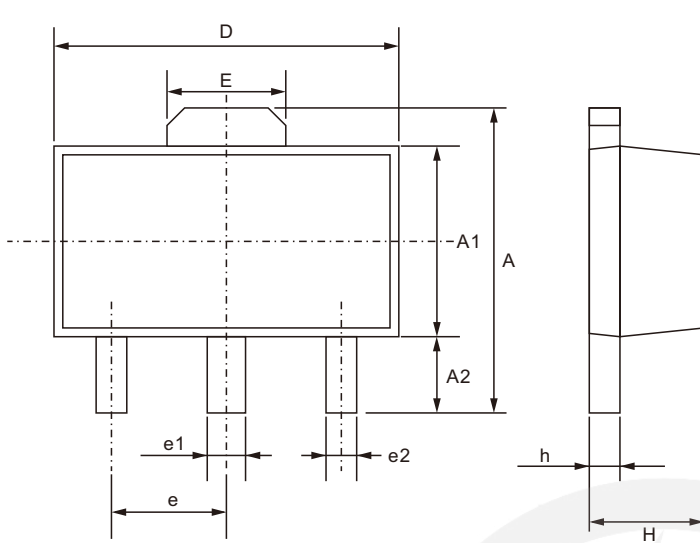

Fig.6 R_{ce} vs I_c





SOT-89 Package Outline



Unit: mm

SYMBOL	DIMENSIONS	
	MIN.	MAX.
A	3.750	4.250
A1	2.400	2.600
A2	0.950	1.050
D	4.400	4.600
E	1.500	1.600
e1	0.470	0.530
e2	0.350	0.450
e	1.500 TYP.	
H	1.400	1.600
h	0.300	0.500

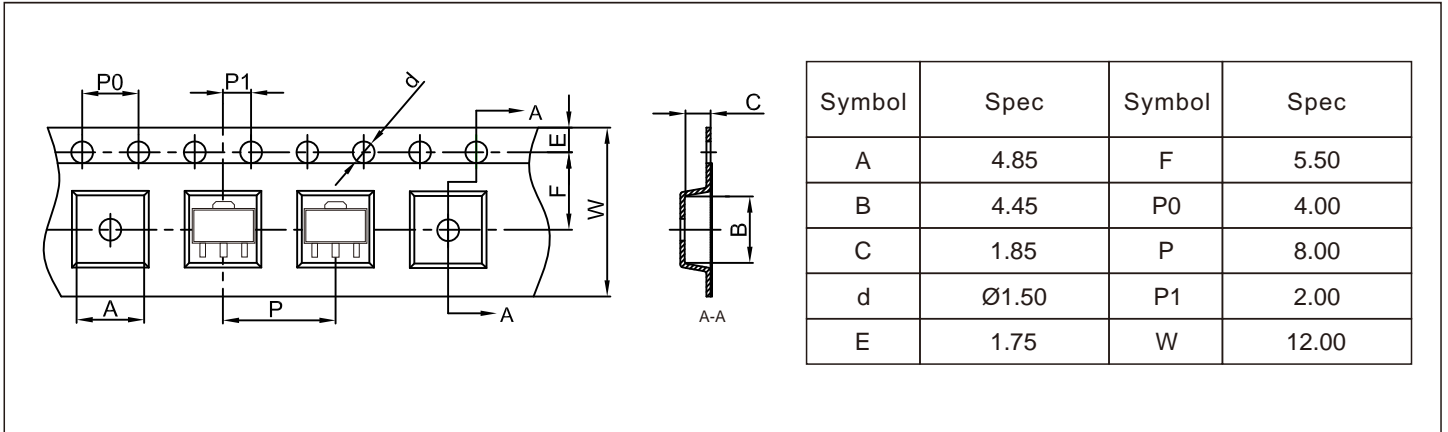
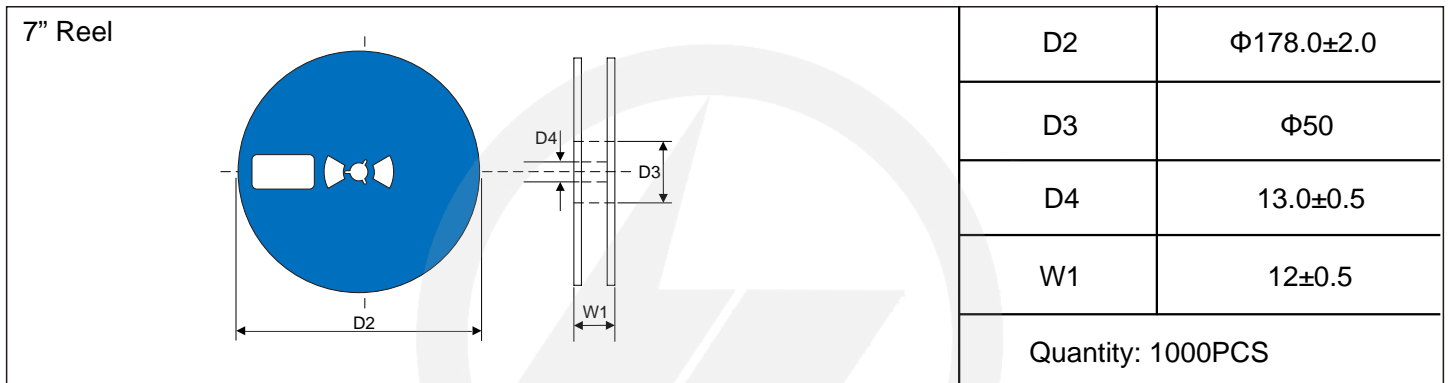
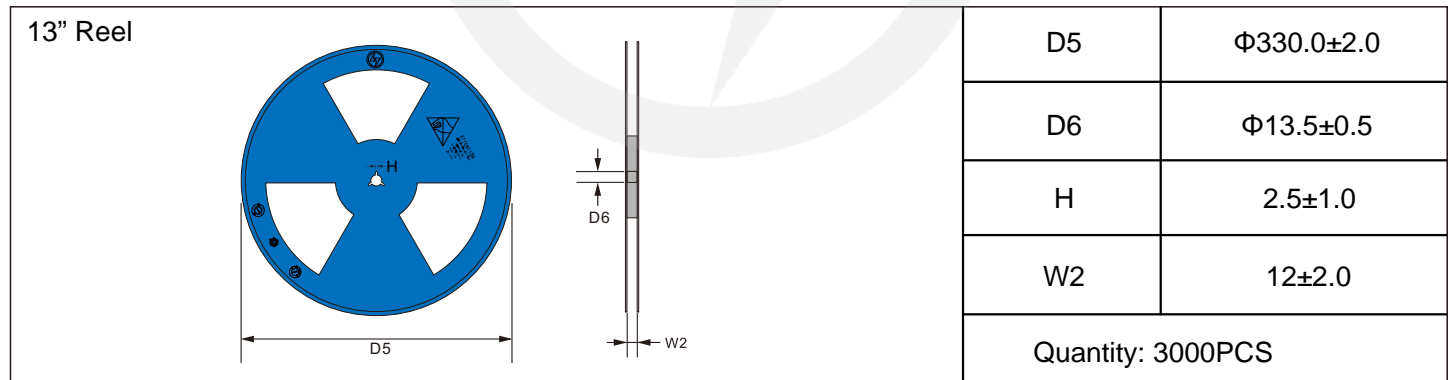
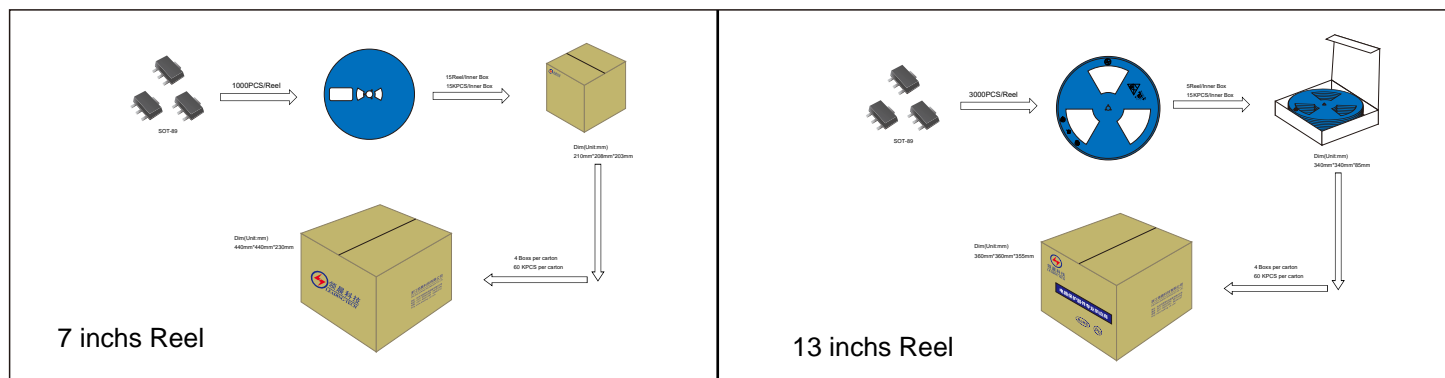
Carrier Tape Dimensions
Unit : mm

Reel Dimensions
Unit : mm

Reel Dimensions
Unit : mm

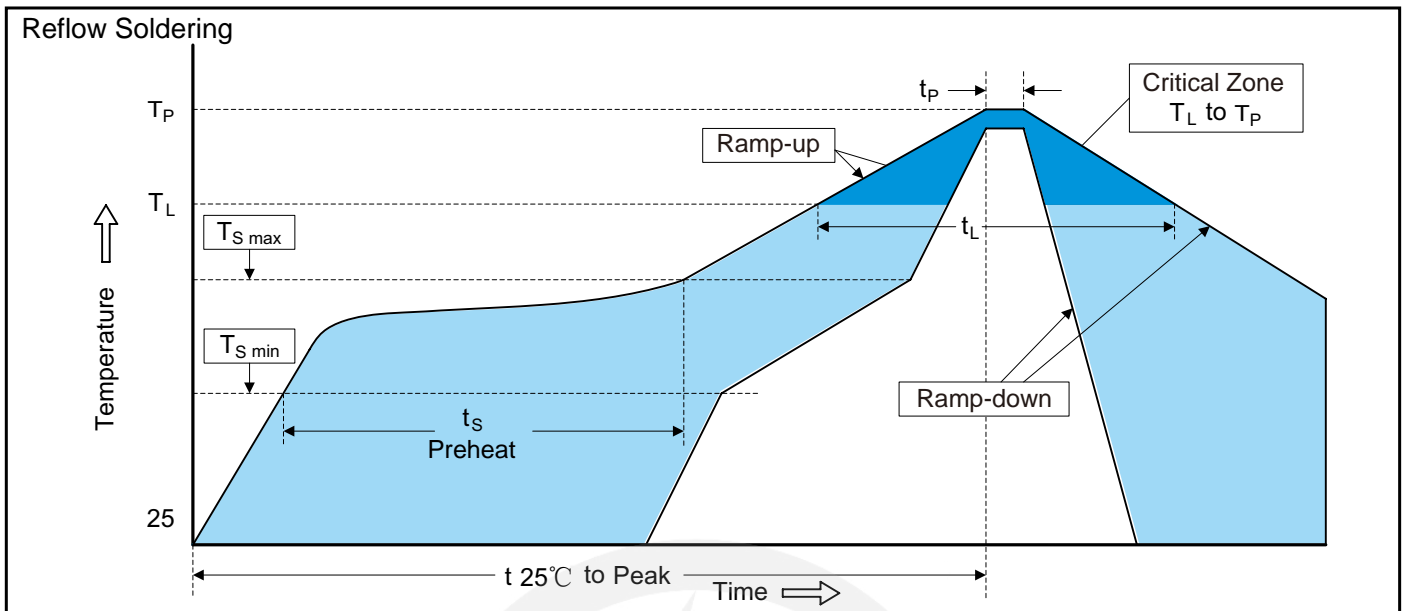
Packaging



Recommended Soldering Conditions



Recommended Conditions

Profile Feature	Pb-Free Assembly
Average ramp-up rate (T _L to T _P)	3°C/second max.
Preheat	
-Temperature Min (T _{S min})	150°C
-Temperature Max (T _{S max})	200°C
-Time (min to max) (t _s)	60-180 seconds
T _{S max} to T _L	
-Ramp-up Rate	3°C/second max.
Time maintained above:	
-Temperature (T _L)	217°C
-Time (t _L)	60-150 seconds
Peak Temperature (T _P)	260°C
Time within 5°C of actual Peak Temperature (t _p)	20-40 seconds
Ramp-down Rate	6°C/second max.
Time 25°C to Peak Temperature	8 minutes max.

Important Notice and Disclaimer

Leading-Tech reserves the right to make changes to this document and its products and specifications at any time without notice.

Customers should obtain and confirm the latest product information and specifications before final design, purchase or use.

Leading-Tech makes no warranty, representation or guarantee regarding the suitability of its products for any particular purpose, not does Leading-Tech assume any liability for application assistance or customer product design.

Leading-tech does not warrant or accept any liability with products which are purchase or used for any unintended or unauthorized application.

No license is granted by implication or otherwise under any intellectual property rights of Leading-Tech.

Leading-Tech products are not authorized for use as critical components in life support devices or systems without express written approval of Leading-tech.

Version Update Information

Series NO.	Enactment/Revision Date	Effective Date	Version	Revision content	Revision Reason	Revision Person	Note
01	2024.10.16	2024.10.16	3.0	New File	/	Ding	
02	2025.06.11	2025.06.11	3.1	Update packaging information	/	Ding	