

Switching Diode

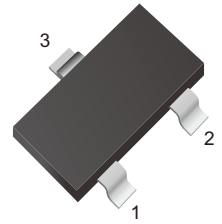

Features

- Fast Switching Speed
- Power Dissipation of 350mW
- High Stability and High Reliability
- Low reverse leakage
- Lead free in comply with EU RoHS 2011/65/EU directives

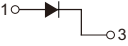

Mechanical Data

- Case: SOT-23
- Approx. Weight: 8.1mg

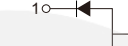
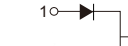
LT4148D1	LT4148D4	LT4148D5	LT4148D6	LT4148D7
				
MARKING:5H	MARKING:D4	MARKING:D5	MARKING:D6	MARKING:D7

Ordering Information

Part Number	Shipping	Reel
LT4148D1/D4/D5/D6/D7-TR3	3000PCS Tape&Reel	7 inches
LT4148D1/D4/D5/D6/D7-TR12	12000PCS Tape&Reel	13 inches

Maximum Ratings at 25 °C

Parameter	Symbol	Limit	Unit
Reverse Voltage	V_R	75	V
Peak Repetitive Peak Reverse Voltage	V_{RRM}	100	V
Average Rectified Output Current	I_O	200	mA
Non-Repetitive Peak Forward Surge Current @ t=8.3ms	I_{FSM}	2.0	A
Power Dissipation	P_D	350	mW
Thermal Resistance Junction to Ambient	$R_{\theta JA}$	357	°C/W
Operation Junction and Storage Temperature Range	T_J, T_{STG}	-55~+150	°C

Electrical Characteristics $T_a = 25^\circ\text{C}$

Parameter	Symbol	Min	Typ	Max	Unit	Conditions
Reverse breakdown voltage	$V_{(BR)}$	75			V	$I_R=100\mu\text{A}$
Forward voltage	V_F			1	V	$I_F=10\text{mA}$
Reverse current	I_{R1}			5	μA	$V_R=75\text{V}$
	I_{R2}			25	nA	$V_R=25\text{V}$
Capacitance between terminals	C_T			4	pF	$V_R=0\text{V}, f=1\text{MHz}$
Reverse recovery time	t_{rr}			4	ns	$I_F=I_R=10\text{mA}, V_R=6\text{V}, I_{rr}=0.1I_R, R_L=100\Omega$

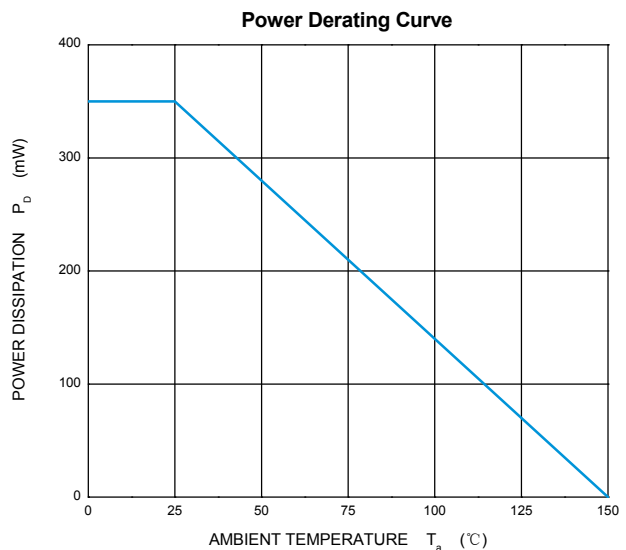
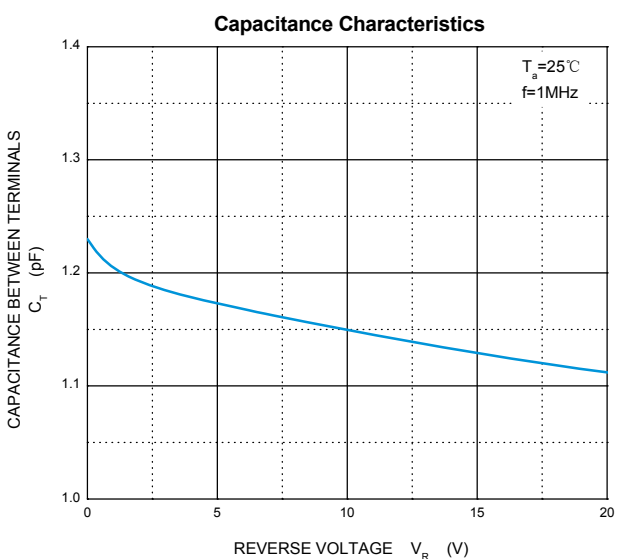
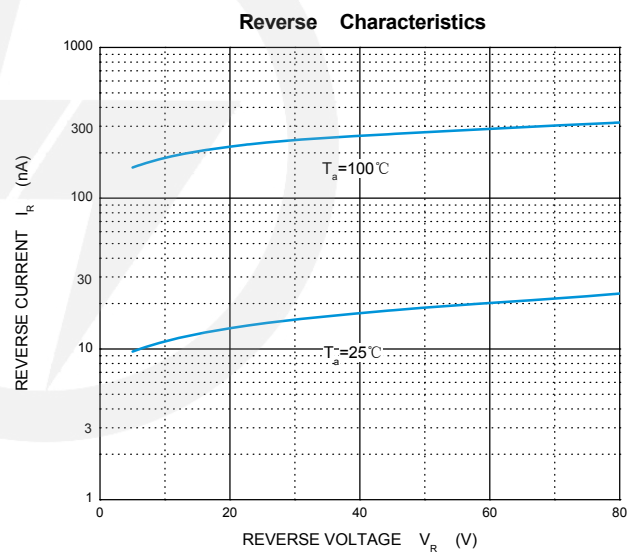
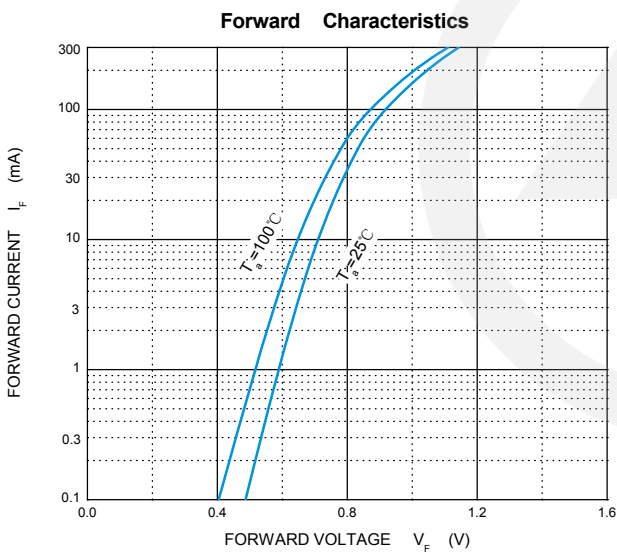
Ratings and characteristics Curves



SOT-23 Package Outline

Unit: mm

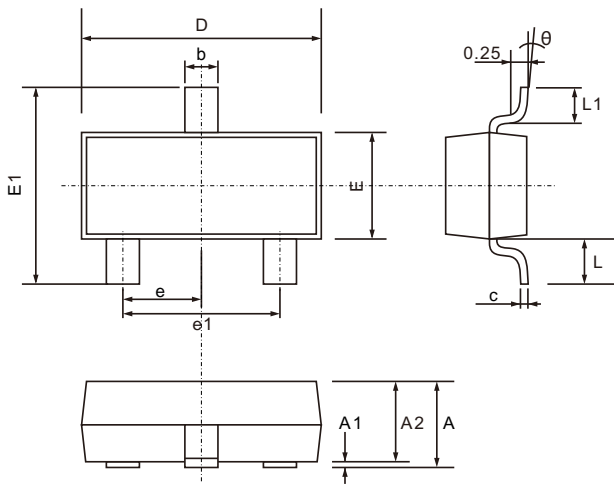

SYMBOL	DIMENSIONS	
	MIN.	MAX.
A	0.900	1.200
A1	0.000	0.100
A2	0.900	1.050
b	0.300	0.500
c	0.080	0.200
D	2.700	3.100
E	1.200	1.400
E1	2.200	2.600
e	0.950 TYP.	
e1	1.750	2.050
L	0.550 TYP.	
L1	0.300	0.500
θ	0°	8°

SOT-23 Suggested Pad Layout

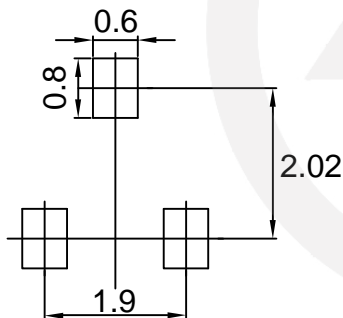

Note:
1. Controlling dimension: in millimeters.
2. General tolerance: ± 0.05mm
3. The pad layout is for reference purpose only.

Carrier Tape Dimensions

Unit : mm

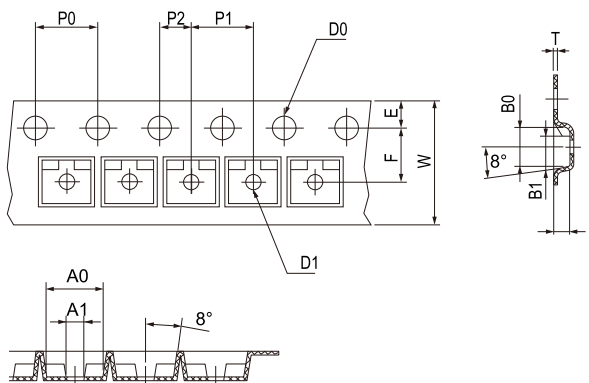
			
Symbol	Spec	Symbol	Spec
A0	3.15±0.10	P0	4.00±0.05
A1	1.09±0.10	P1	4.00±0.02
B0	2.77±0.10	W	8.00±0.10
B1	2.15±0.10	E	1.75±0.10
K0	1.22±0.10	F	3.50±0.05
D0	1.50±0.10	T	2.00±0.10
D1	1.00±0.10		

Reel Dimensions

Unit : mm

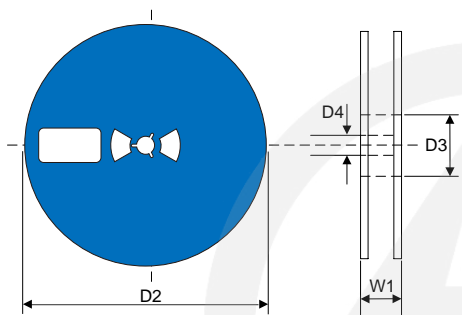
7" Reel 	D2	Φ178.0±2.0
	D3	Φ50
	D4	13.0±0.5
	W1	12±0.5
	Quantity: 3000PCS	

Reel Dimensions

Unit : mm

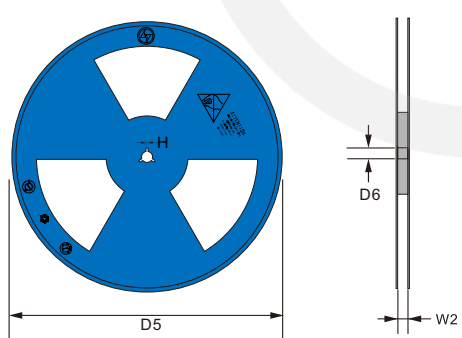
13" Reel 	D5	Φ330.0±2.0
	D6	Φ13.5±0.5
	H	2.5±1.0
	W2	12±2.0
	Quantity: 12000PCS	

Packaging

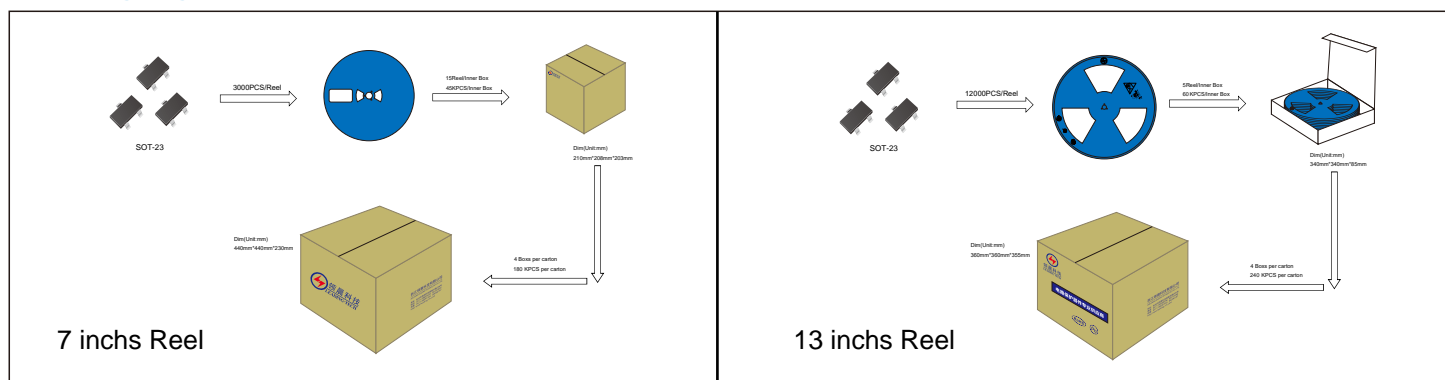



Recommended Soldering Conditions

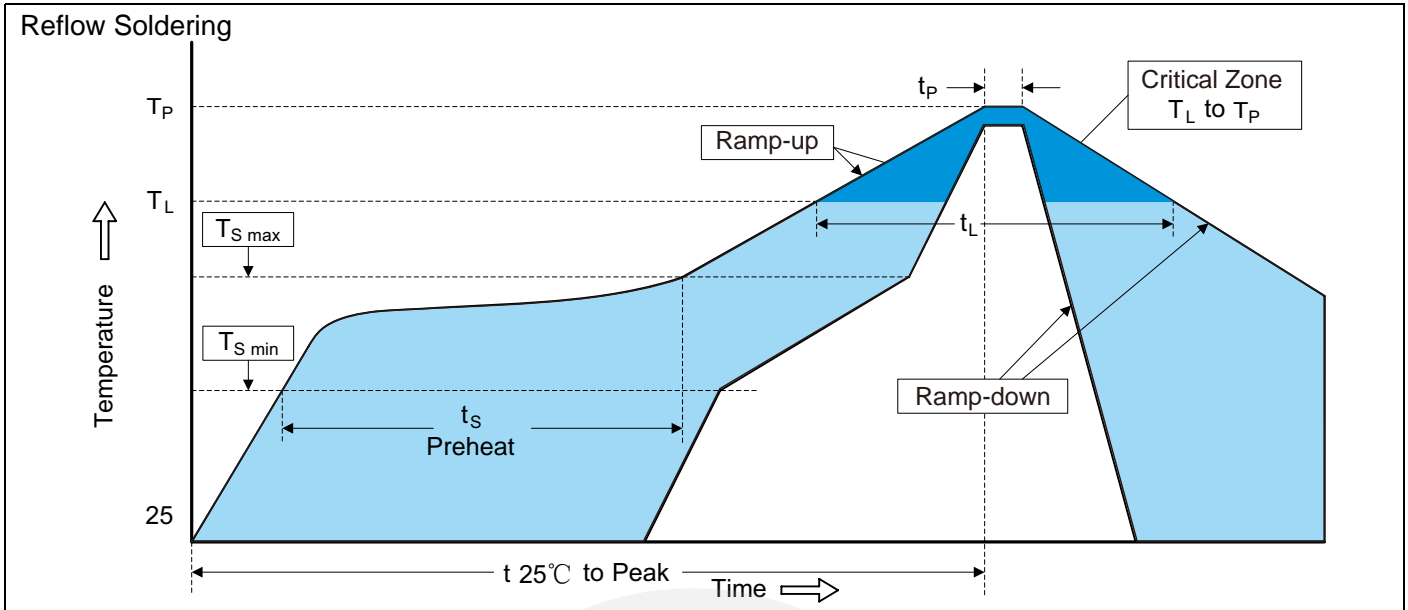

Recommended Conditions

Profile Feature	Pb-Free Assembly
Average ramp-up rate (T _L to T _P)	3°C/second max.
Preheat -Temperature Min (T _{S min}) -Temperature Max (T _{S max}) -Time (min to max) (t _S)	150°C 200°C 60-180 seconds
T _{S max} to T _L -Ramp-up Rate	3°C/second max.
Time maintained above: -Temperature (T _L) -Time (t _L)	217°C 60-150 seconds
Peak Temperature (T _P)	260°C
Time within 5°C of actual Peak Temperature (t _P)	20-40 seconds
Ramp-down Rate	6°C/second max.
Time 25°C to Peak Temperature	8 minutes max.

Important Notice and Disclaimer

Leading-Tech reserves the right to make changes to this document and its products and specifications at any time without notice.

Customers should obtain and confirm the latest product information and specifications before final design, purchase or use.

Leading-Tech makes no warranty, representation or guarantee regarding the suitability of its products for any particular purpose, not does Leading-Tech assume any liability for application assistance or customer product design.

Leading-Tech does not warrant or accept any liability with products which are purchase or used for any unintended or unauthorized application.

No license is granted by implication or otherwise under any intellectual property rights of Leading-Tech.

Leading-Tech products are not authorized for use as critical components in life support devices or systems without express written approval of Leading-Tech.

Version Update information

Series NO.	Enactment/Revision Date	Effective Date	Version	Revision Content	Revision Reason	Revision Person	Note
01	2024.03.01	2024.03.01	3.0	New file	/	Ding	
02	2025.06.17	2025.06.17	3.1	Update packaging information	/	Ding	
03	2026.03.04	2026.03.04	3.2	Package outline E1(max)=2.6mm	/	Ding	