

Surface Mount Schottky Barrier Rectifier

Features

- Metal silicon junction, majority carrier conduction
- For surface mounted applications
- Low power loss, high efficiency
- High forward surge current capability
- For use in low voltage, high frequency inverters, free wheeling, and polarity protection applications
- Lead free in comply with EU RoHS 2011/65/EU directives

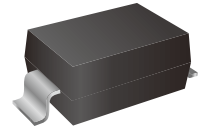

Mechanical Data

- Case:SMAW
- Terminal:Leads solderable per MIL-STD-750 Method 2026
- Polarity:Color band denotes cathode end
- Mounting Position:Any



Ordering Information

Part Number	Marking	Shipping	Reel
LT3S40W	S34W	8000PCS Tape&Reel	13 inchs

Absolute Maximum Ratings and Electrical characteristics

Ratings at 25 °C ambient temperature unless otherwise specified.

Single phase, half wave, 60Hz resistive or inductive load,for capacitive load, derate by 20 %.

Parameter	Symbol	LT3S40W	Unit
Maximum Repetitive Peak Reverse Voltage	V_{RRM}	40	V
Maximum RMS voltage	V_{RMS}	28	V
Maximum DC Blocking Voltage	V_{DC}	40	V
Maximum Average Forward Rectified Current at $T_c=100\text{ }^\circ\text{C}$	$I_{F(AV)}$	3	A
Peak Forward Surge Current 8.3 ms Single Half Sine Wave Superimposed on Rated Load	I_{FSM}	100	A
Maximum Instantaneous Forward Voltage at 3 A	V_F	0.45	V
Maximum DC Reverse Current at Rated DC Blocking Voltage $T_a=25\text{ }^\circ\text{C}$ $T_a=100\text{ }^\circ\text{C}$	I_R	0.3 5	mA
Typical Junction Capacitance (Note1)	C_j	700	pF
Typical Thermal Resistance (Note2)	$R_{\theta JA}$ $R_{\theta JC}$	60 18	$^\circ\text{C/W}$
Operating Junction Temperature Range	T_j	-55 ~ +125	$^\circ\text{C}$
Storage Temperature Range	T_{stg}	-55 ~ +125	$^\circ\text{C}$

Note: (1) Measured at 1 MHz and applied reverse voltage of 4V DC.

(2) PCB mounted with 2.0" X 2.0" (5cm X 5cm) copper pad areas.



Characteristics Curves

Fig.1 Forward Current Derating Curve

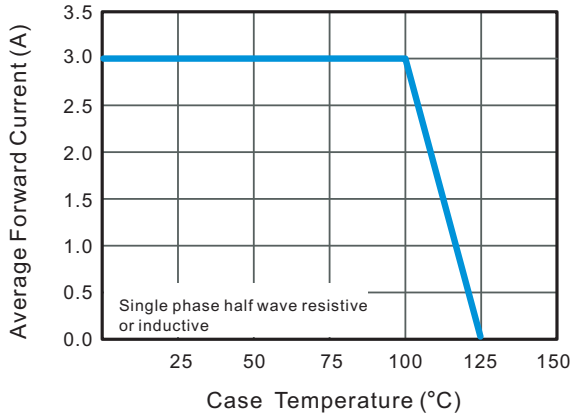

Fig.2 Typical Reverse Characteristics

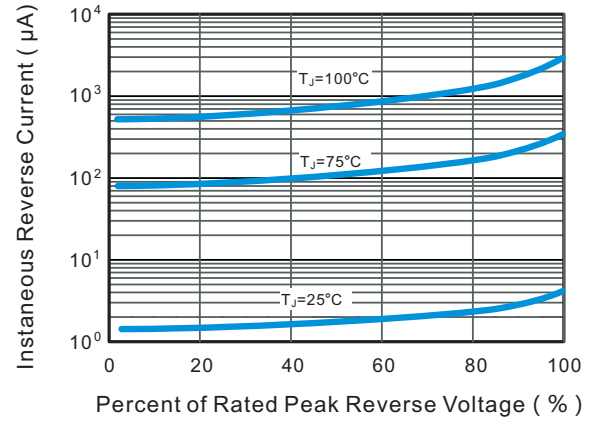

Fig.3 Typical Forward Characteristic

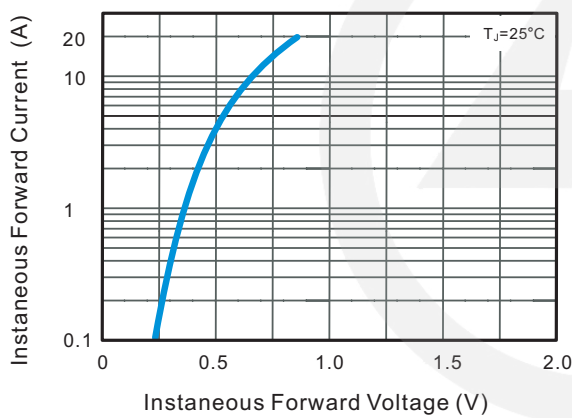

Fig.4 Typical Junction Capacitance

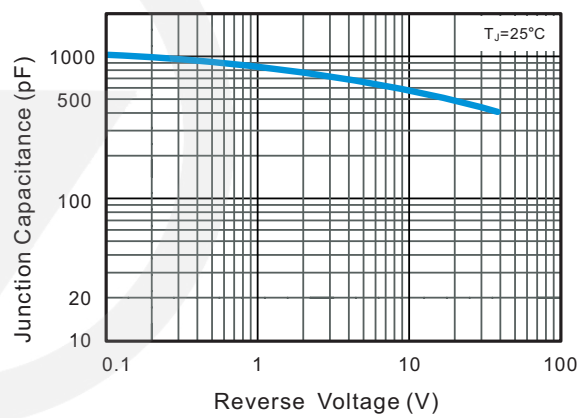

Fig.5 Maximum Non-Repetitive Peak Forward Surge Current

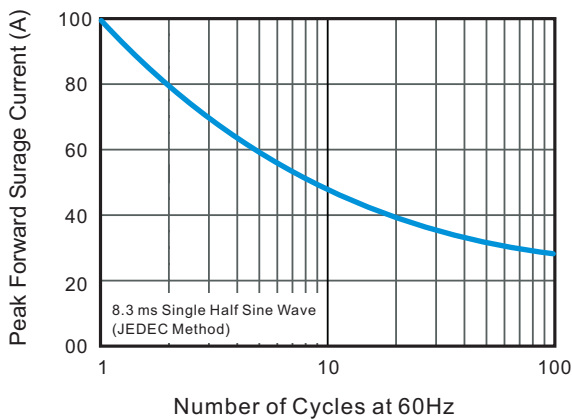
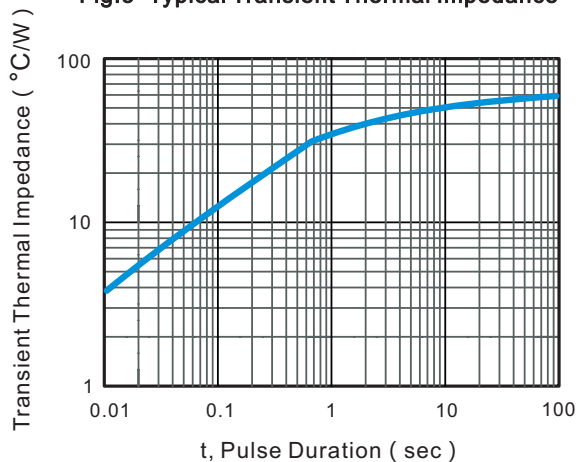
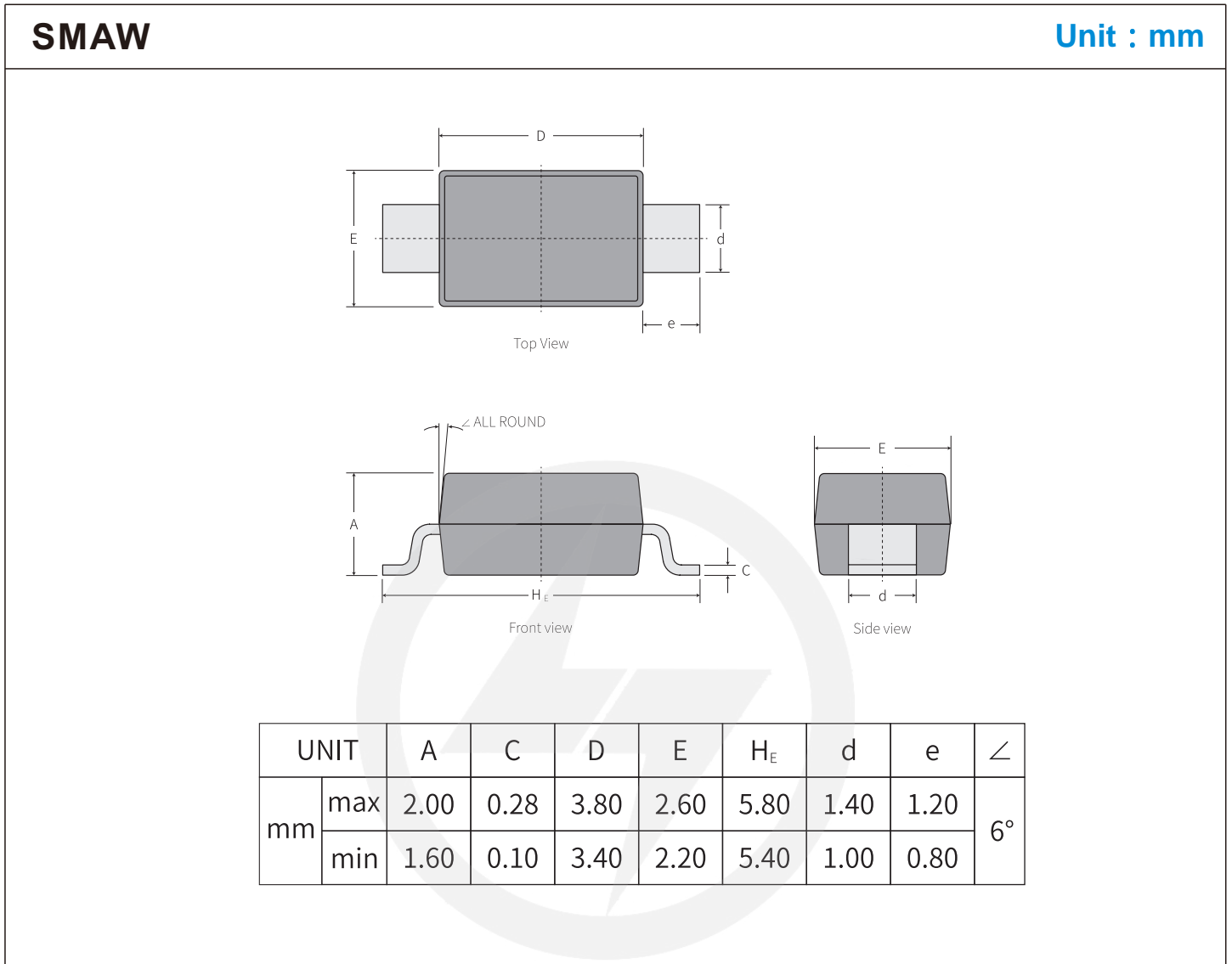
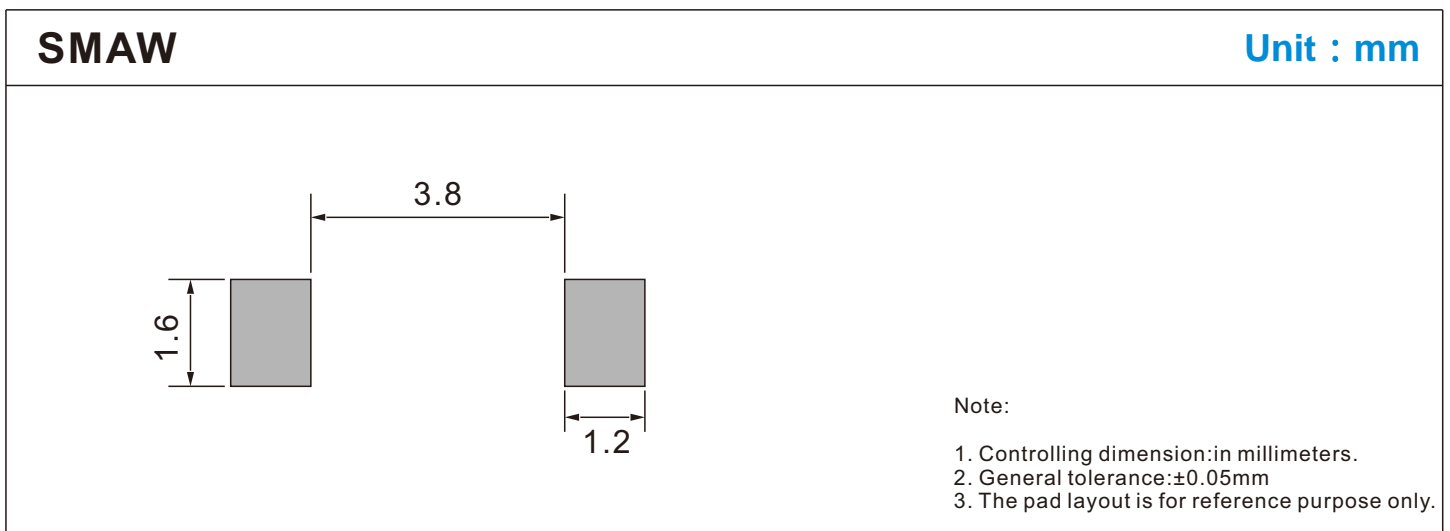

Fig.5- Typical Transient Thermal Impedance



Package Outline

Suggested Pad Layout

Carrier Tape Dimensions

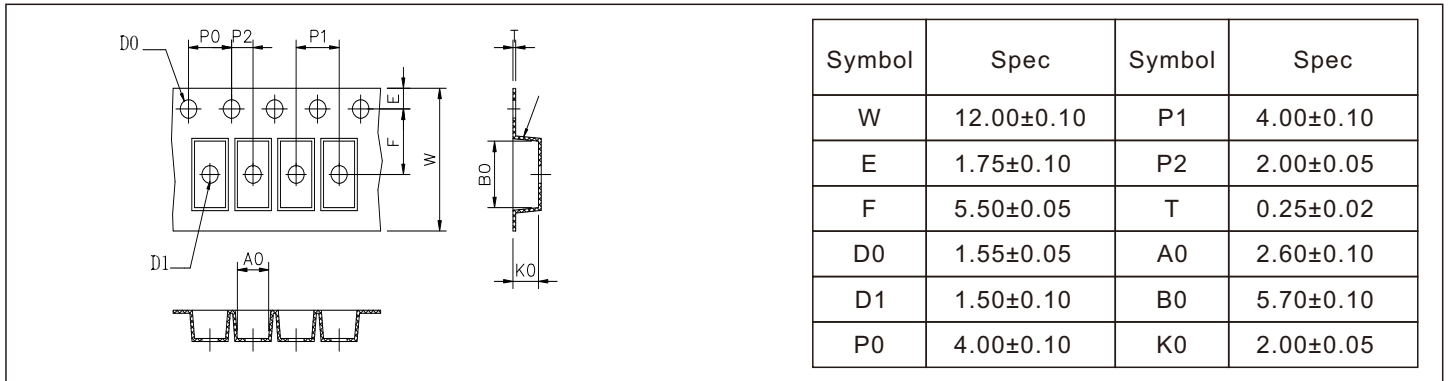
Unit : mm



Reel Dimensions

Unit : mm

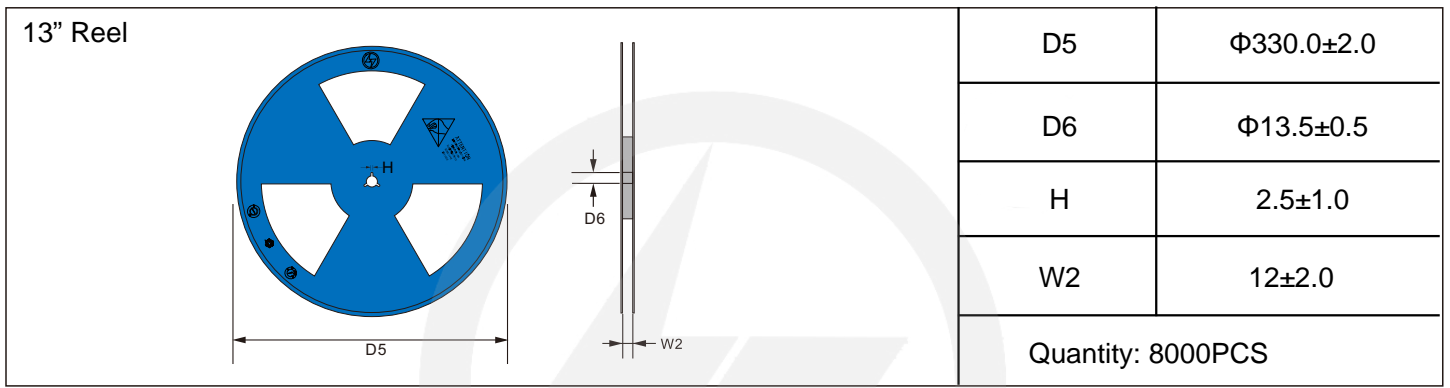

Packaging

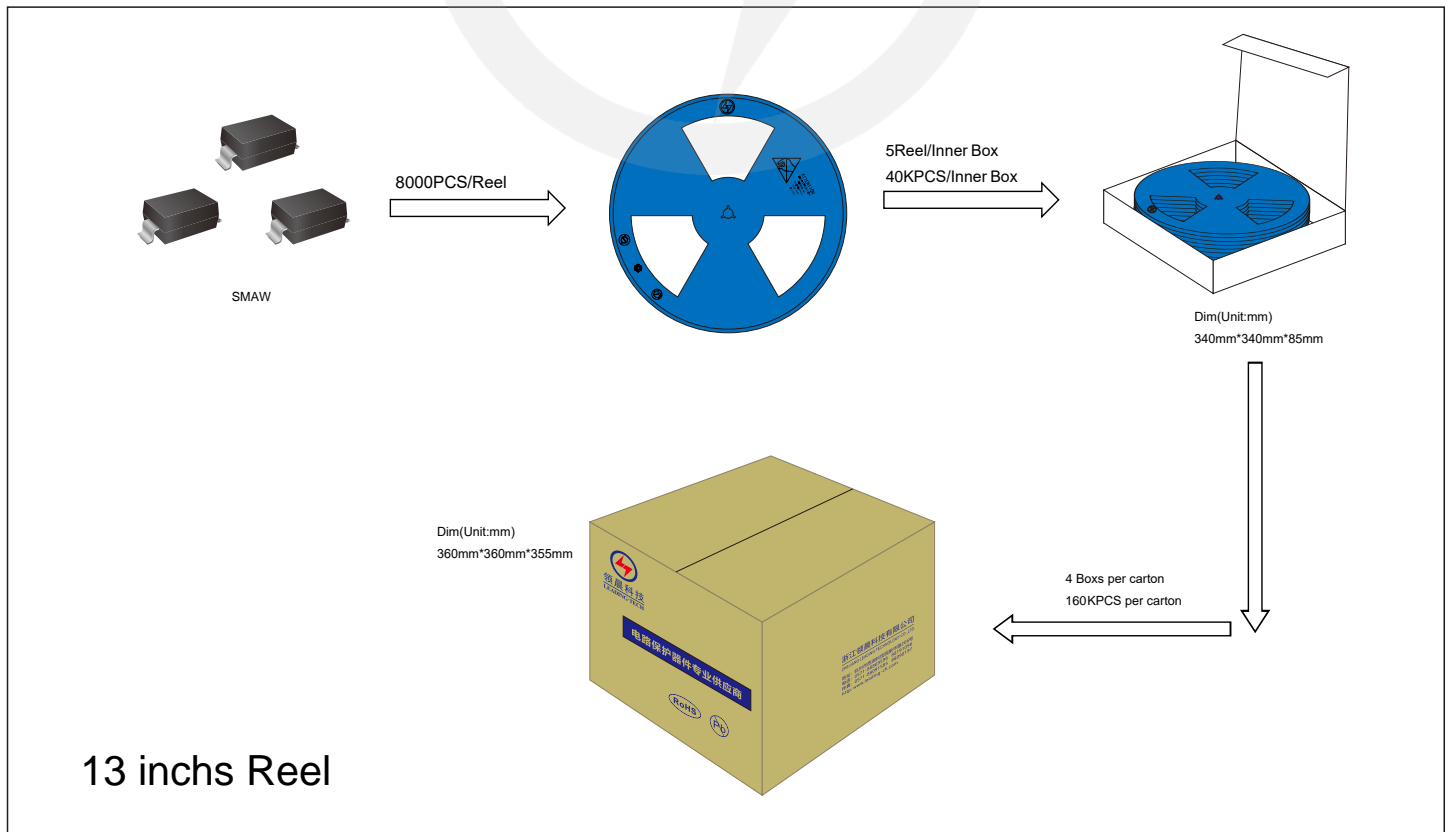



Recommended Soldering Conditions

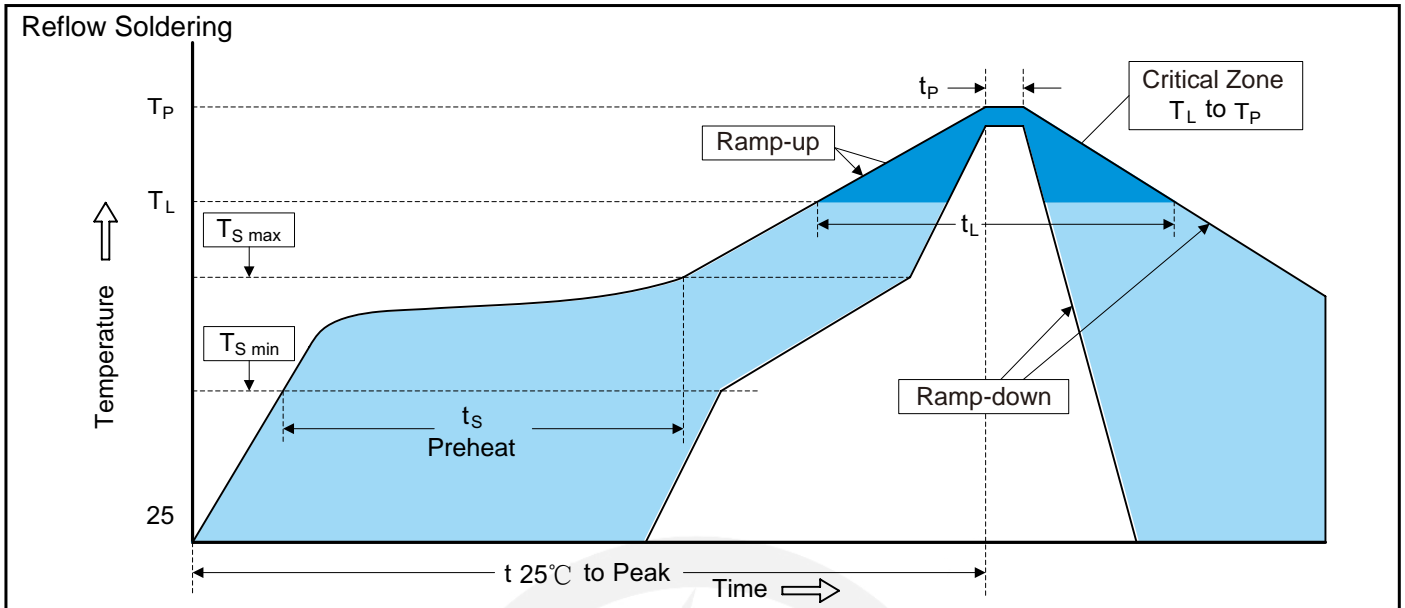

Recommended Conditions

Profile Feature	Pb-Free Assembly
Average ramp-up rate (T_L to T_P)	3°C/second max.
Preheat	
-Temperature Min ($T_{S\ min}$)	150°C
-Temperature Max ($T_{S\ max}$)	200°C
-Time (min to max) (t_s)	60-180 seconds
$T_{S\ max}$ to T_L	
-Ramp-up Rate	3°C/second max.
Time maintained above:	
-Temperature (T_L)	217°C
-Time (t_L)	60-150 seconds
Peak Temperature (T_P)	260°C
Time within 5°C of actual Peak Temperature (t_p)	20-40 seconds
Ramp-down Rate	6°C/second max.
Time 25°C to Peak Temperature	8 minutes max.

Important Notice and Disclaimer

Leading-Tech reserves the right to make changes to this document and its products and specifications at any time without notice.

Customers should obtain and confirm the latest product information and specifications before final design, purchase or use.

Leading-Tech makes no warranty, representation or guarantee regarding the suitability of its products for any particular purpose, not does Leading-Tech assume any liability for application assistance or customer product design.

Leading-tech does not warrant or accept any liability with products which are purchase or used for any unintended or unauthorized application.

No license is granted by implication or otherwise under any intellectual property rights of Leading-Tech.

Leading-Tech products are not authorized for use as critical components in life support devices or systems without express written approval of Leading-tech.

Version Update Information

Series NO.	Enactment/Revision Date	Effective Date	Version	Revision content	Revision Reason	Revision Person	Note
01	2025.01.03	2025.01.03	1.0	New File	/	Ding	
02	2025.06.30	2025.06.30	1.1	Update packaging information	/	Ding	