

Transistor(NPN)

Features

- Lead free in comply with EU RoHS 2011/65/EU directives

Mechanical Data

- Case: SOT-23
- Approx. Weight: 8.1mg

Ordering Information

| Part Number | Marking | Shipping | Reel |
|-------------|---------|--------------------|-----------|
| LT3904-TR3 | 1AM | 3000PCS Tape&Reel | 7 inches |
| LT3904-TR12 | 1AM | 12000PCS Tape&Reel | 13 inches |



Maximum Ratings (Ta=25 unless otherwise noted)

| Symbol | Parameter | Value | Unit |
|-----------------|---|----------|------|
| V_{CBO} | Collector-Base Voltage | 60 | V |
| V_{CEO} | Collector-Emitter Voltage | 40 | V |
| V_{EBO} | Emitter-Base Voltage | 6 | V |
| I_C | Collector Current | 200 | mA |
| P_C | Collector Power Dissipation | 200 | mW |
| $R_{\theta JA}$ | Thermal Resistance From Junction To Ambient | 625 | °C/W |
| T_j | Junction Temperature | 150 | °C |
| T_{stg} | Storage Temperature | -55~+150 | °C |

Electrical characteristics (Ta=25 unless otherwise specified)

| Parameter | Symbol | Test condition | Min | Typ | Max | Unit |
|--------------------------------------|---------------|--|-----|-----|------|------|
| Collector-base breakdown voltage | $V_{(BR)CBO}$ | $I_C=10\mu A, I_E=0$ | 60 | | | V |
| Collector-emitter breakdown voltage | $V_{(BR)CEO}$ | $I_C=1mA, I_B=0$ | 40 | | | V |
| Emitter-base breakdown voltage | $V_{(BR)EBO}$ | $I_E=10\mu A, I_C=0$ | 6 | | | V |
| Collector cut-off current | I_{CEX} | $V_{CE}=30V, V_{EB(off)}=3V$ | | | 50 | nA |
| Collector cut-off current | I_{CBO} | $V_{CB}=60V, I_E=0$ | | | 100 | nA |
| Emitter cut-off current | I_{EBO} | $V_{EB}=5V, I_C=0$ | | | 100 | nA |
| DC current gain | $h_{FE(1)}$ | $V_{CE}=1V, I_C=10mA$ | 100 | | 300 | |
| | $h_{FE(2)}$ | $V_{CE}=1V, I_C=50mA$ | 60 | | | |
| | $h_{FE(3)}$ | $V_{CE}=1V, I_C=100mA$ | 30 | | | |
| Collector-emitter saturation voltage | $V_{CE(sat)}$ | $I_C=50mA, I_B=5mA$ | | | 0.3 | V |
| Base-emitter saturation voltage | $V_{BE(sat)}$ | $I_C=50mA, I_B=5mA$ | | | 0.95 | V |
| Transition frequency | f_T | $V_{CE}=20V, I_C=10mA, f=100MHz$ | 300 | | | MHz |
| Delay time | t_d | $V_{CC}=3V, V_{BE(off)}=-0.5V, I_C=10mA, I_{B1}=1mA$ | | | 35 | ns |
| Rise time | t_r | $V_{CC}=3V, V_{BE(off)}=-0.5V, I_C=10mA, I_{B1}=1mA$ | | | 35 | ns |
| Storage time | t_s | $V_{CC}=3V, I_C=10mA, I_{B1}=I_{B2}=1mA$ | | | 200 | ns |
| Fall time | t_f | $V_{CC}=3V, I_C=10mA, I_{B1}=I_{B2}=1mA$ | | | 50 | ns |



Characteristics Curves

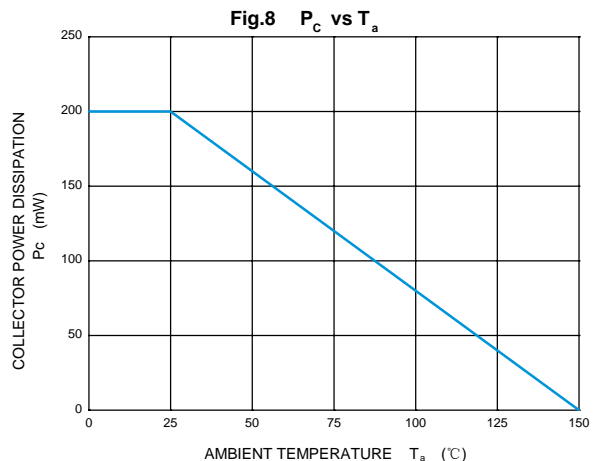
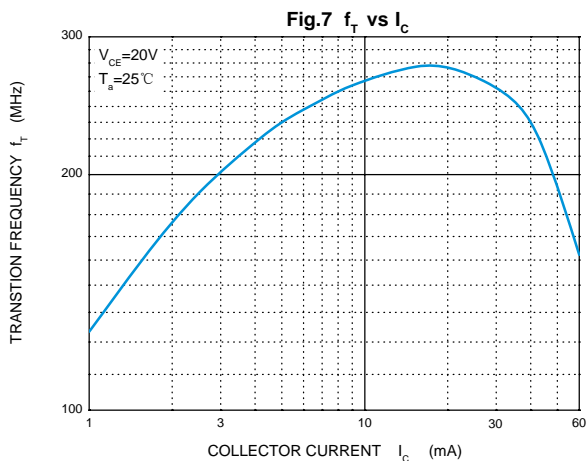
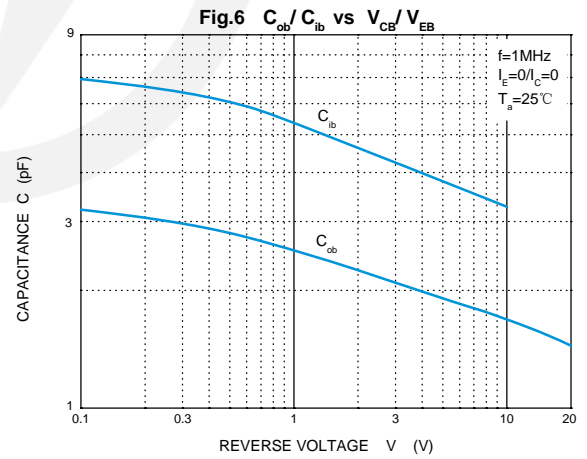
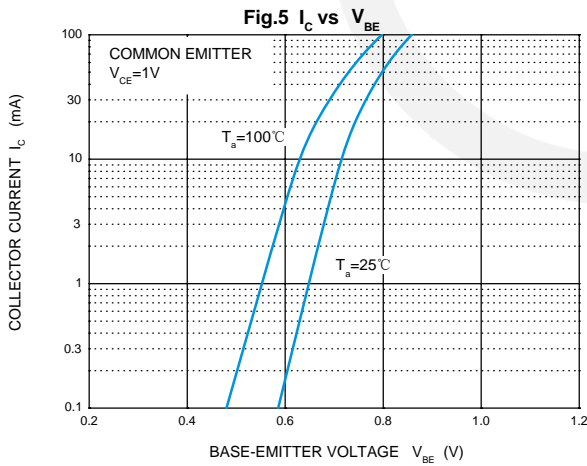
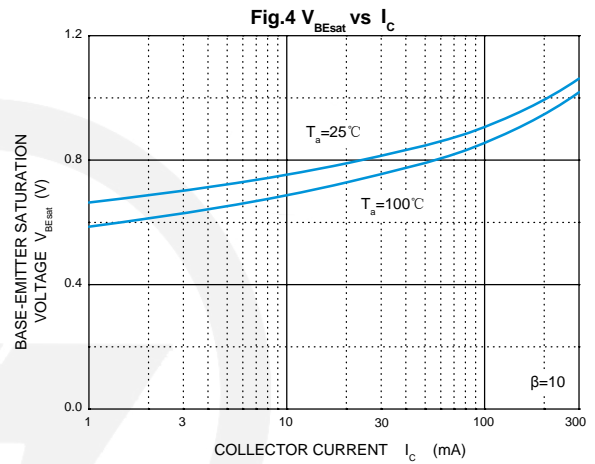
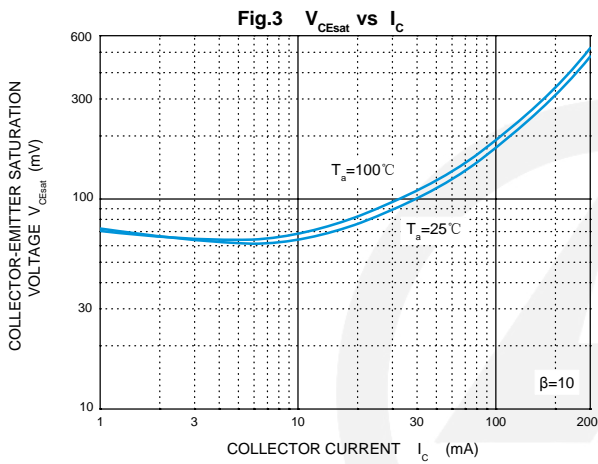
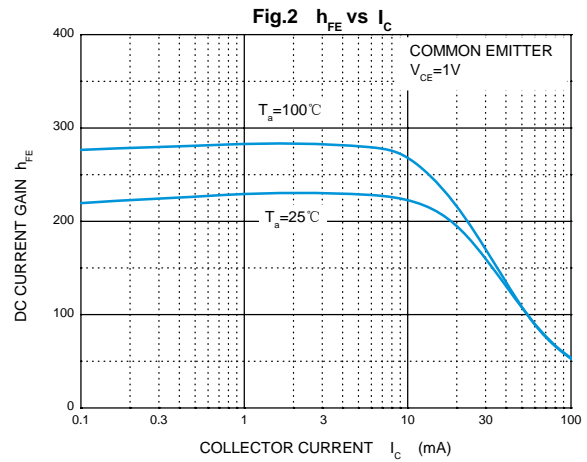
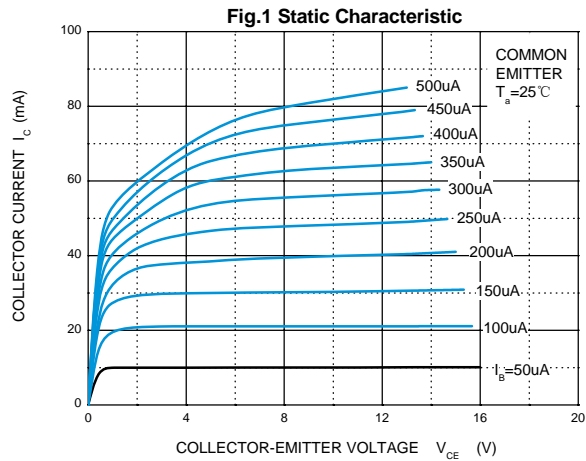



SOT-23 Package Outline

Unit: mm

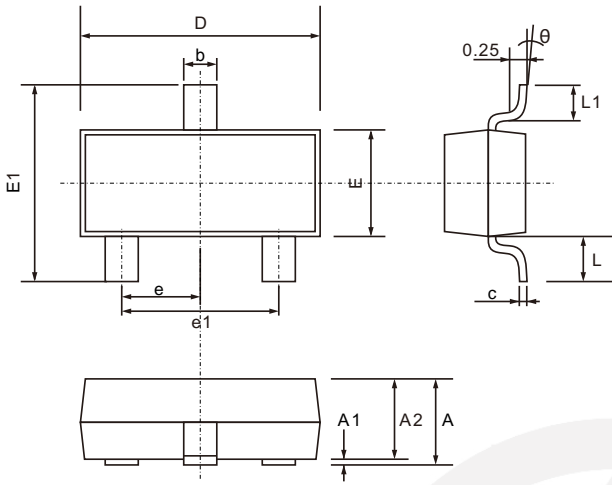

| SYMBOL | DIMENSIONS | |
|--------|------------|-------|
| | MIN. | MAX. |
| A | 0.900 | 1.200 |
| A1 | 0.000 | 0.100 |
| A2 | 0.900 | 1.050 |
| b | 0.300 | 0.500 |
| c | 0.080 | 0.200 |
| D | 2.700 | 3.100 |
| E | 1.200 | 1.400 |
| E1 | 2.200 | 2.600 |
| e | 0.950 TYP. | |
| e1 | 1.750 | 2.050 |
| L | 0.550 TYP. | |
| L1 | 0.300 | 0.500 |
| θ | 0° | 8° |

SOT-23 Suggested Pad Layout

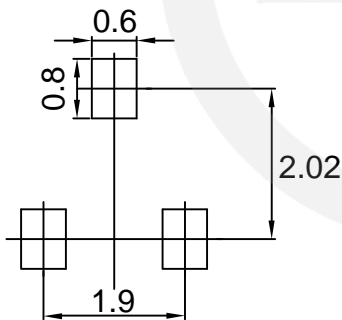

Note:
 1. Controlling dimension: in millimeters.
 2. General tolerance: ± 0.05mm
 3. The pad layout is for reference purpose only.

Carrier Tape Dimensions

Unit : mm

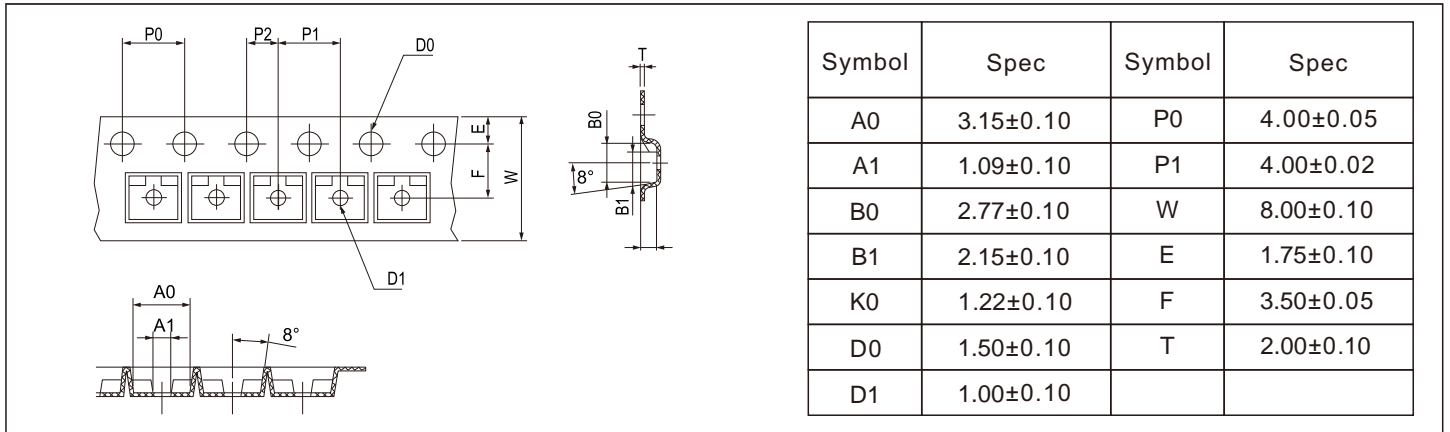

Reel Dimensions

Unit : mm

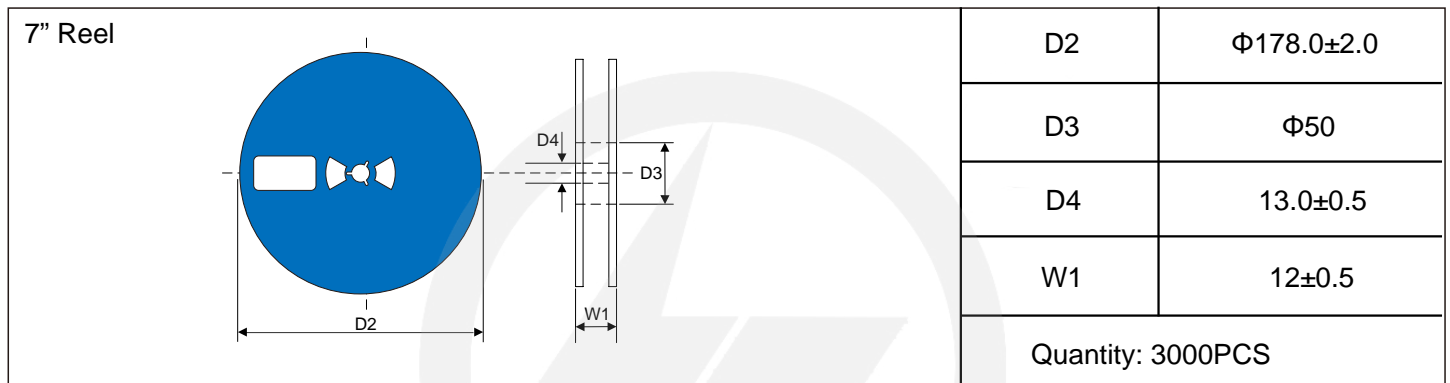

Reel Dimensions

Unit : mm

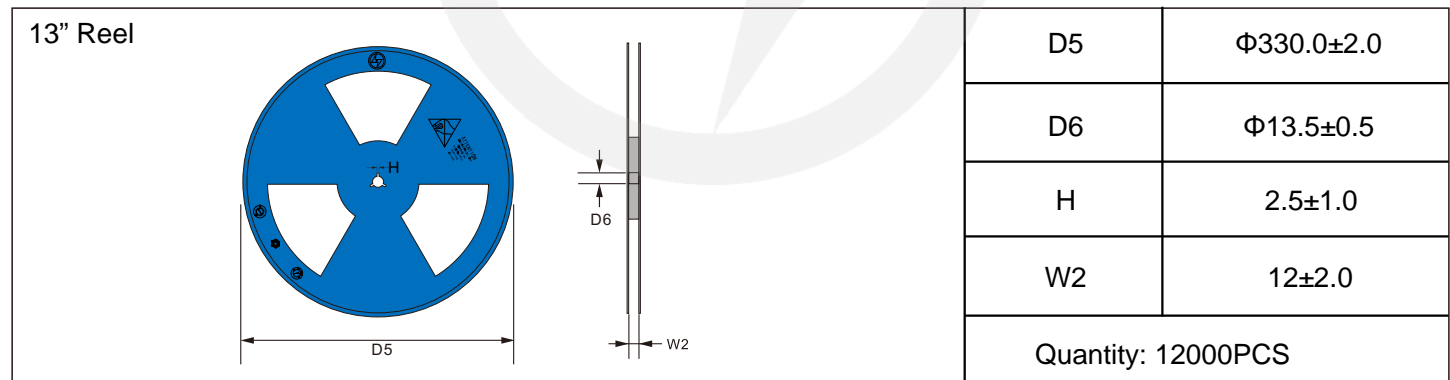

Packaging

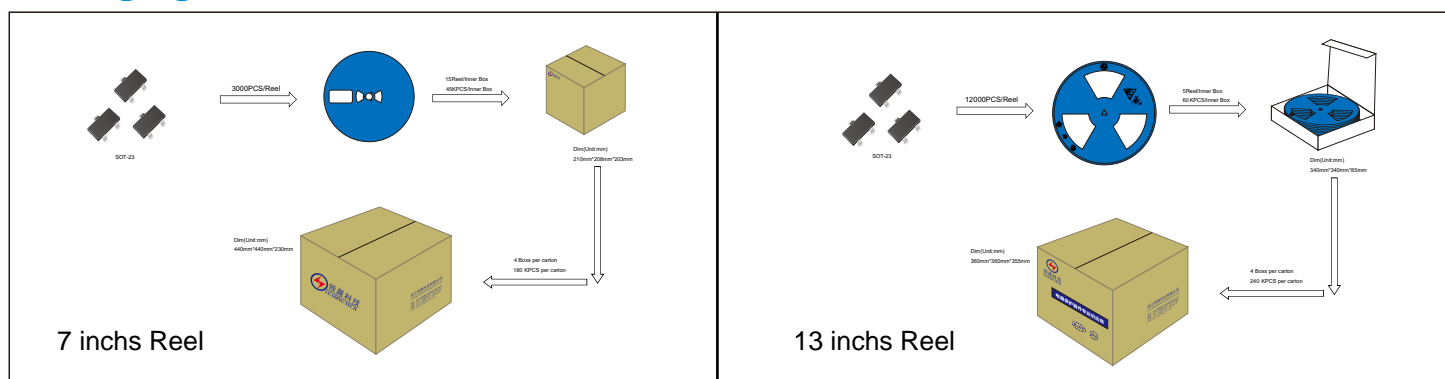



Recommended Soldering Conditions



Recommended Conditions

| Profile Feature | Pb-Free Assembly |
|--|------------------|
| Average ramp-up rate (T _L to T _P) | 3°C/second max. |
| Preheat | |
| -Temperature Min (T _{S min}) | 150°C |
| -Temperature Max (T _{S max}) | 200°C |
| -Time (min to max) (t _s) | 60-180 seconds |
| T _{S max} to T _L | |
| -Ramp-up Rate | 3°C/second max. |
| Time maintained above: | |
| -Temperature (T _L) | 217°C |
| -Time (t _L) | 60-150 seconds |
| Peak Temperature (T _P) | 260°C |
| Time within 5°C of actual Peak Temperature (t _p) | 20-40 seconds |
| Ramp-down Rate | 6°C/second max. |
| Time 25°C to Peak Temperature | 8 minutes max. |

Important Notice and Disclaimer

Leading-Tech reserves the right to make changes to this document and its products and specifications at any time without notice.

Customers should obtain and confirm the latest product information and specifications before final design, purchase or use.

Leading-Tech makes no warranty, representation or guarantee regarding the suitability of its products for any particular purpose, not does Leading-Tech assume any liability for application assistance or customer product design.

Leading-Tech does not warrant or accept any liability with products which are purchase or used for any unintended or unauthorized application.

No license is granted by implication or otherwise under any intellectual property rights of Leading-Tech.

Leading-Tech products are not authorized for use as critical components in life support devices or systems without express written approval of Leading-Tech.

Version Update Information

| Series NO. | Enactment/Revision Date | Effective Date | Version | Revision Content | Revision Reason | Revision Person | Note |
|------------|-------------------------|----------------|---------|-------------------------------|-----------------|-----------------|------|
| 01 | 2024.03.12 | 2024.03.12 | 3.0 | New file | / | Ding | |
| 02 | 2025.06.17 | 2025.06.17 | 3.1 | Update packaging information | / | Ding | |
| 03 | 2026.03.06 | 2026.03.06 | 3.2 | Package outline E1(max)=2.6mm | / | Ding | |